

PORTER® PRECISION METRIC

This drawing contains proprietary information from Porter Precision Products Co. and is not to be copied or re-distributed without written permission.

TOLERANCES	XXX-1/-1.66	5.08
UNLESS	XXX-2/-0.13	
SPECIFIED	XXX-3/-0.01	
	XXX-4/-0.005	
	XXX-5/+1.27	
	ANG-1/- .50	



PORTER PRECISION PRODUCTS CO.

HEAD TYPE PUNCHES

4	Standard Retracto Punches and Blanks	R	RQ
5	Ultra Precision Retracto Punches & Blanks	PR	PRQ
6	Standard Solid Punches & Blanks	S	SQ
7	Ultra Precision Solid Punches and Blanks	P	PQ
8	Xtreme Retracto Punches & Blanks	XR	XRQ
9	Xtreme Solid Punches & Blanks	XS	XSQ
10	Xtreme Center Dowel Retracto Punches & Blanks	CDXR	CDXRQ
11	Xtreme Center Dowel Solid Punches & Blanks	CDXS	CDXSQ
12	Center Dowel Retracto Punches	CDR	CDRQ
13	Center Dowel Pilots & Blanks	CDS	CDSQ ... CDSAP
14	Standard Pilot Punches	SP	SAP
15	Ultra Precision Pilot Punches	PP	PAP
16	Standard and Ultra Precision Sur-Align Pilots	SAPQ	SAPN ... PAPQ ... PAPN
22	Trumpet Head Punches	TR	TS ... TRQ ... TSQ

BAL-LOK AND HEADLESS PUNCHES

17	Headless Retracto & Solid Punches & Blanks	HR	H	HRQ	HQ
26	Heavy Duty Retracto Punches & Blanks	HBR	HBRB		
27	Heavy Duty Punches & Blanks	HB	HBB		
28	Heavy Duty Knobs & Bal-Lok Release Tools	HBKR	HBK	BRT	
29	Heavy Duty Pilots	HBP	HBAP	HBLP	
30	Light Duty Retracto Punches & Blanks	BR	BRB		
31	Light Duty Solid Punches & Blanks	B	BB		
32	Light Duty Knobs	BKR	BK		
33	Light Duty Pilots	BP	BAP	BLP	

PERFORATORS, HOLDERS, AND SUPPORT SLEEVES

24	Headed Perforators	HP	NPP	NAP
25	Support Sleeves	CQ	BHQ	

DIE BUTTONS

18	Headed & Headless Counterbore Dies	HND	ND		
19	Standard Taper Dies & Blanks	HDT	DT	HNDW	NDW
20	Precision Taper Dies	HPD	PD		
21	Bal-Lok Die Buttons & Blanks – Steel Guide Bushings	BD	BDW	GL	GD ... GU

RETAINERS

23	Trumpet Head Retainers	THR	
34	Head Type Retainers	MSR	MRR
35	Bal-Lok Retainers	MHR	MLR

ADDITIONAL ITEMS AND INFORMATION

36	Standard Forms
37	Standard Forms
38	Extrusion Tips
39	Extrusion Tips & Punch Shear
40	Extrusion Dies
41	Stamps & Retracto Replacement Components
42	Standard Alterations
43	Views
44	Locating Flats
45	Locating Flats & Dowels
46	Urethane Strippers
47	Treatments
48	Coatings

STANDARD CATALOG ITEMS (Up to 32 mm Ø Body)
NUMBER OF WORK DAYS TO SHIPMENT

Description	1-19 Pieces	20-50 Pieces
Blanks, Steel Springs, Urethane	1	1
Round Punches (Circular Point)	2	5
Round Dies (Circular ID)	2	5
Shape Punches (flatted round, oblong, square, rectangle)	4	7
Shape Dies (flatted round, oblong, square, rectangle)	4	7
'Z' Shapes - (01 - 16) Page 36 & 37	6	9
'Z' Shapes - (All Others) Page 36 & 37	8	11
Pilots	3	5
Knob Style Punches - Pages 28 & 32	8	12
Guide Bushings - Page 21	3	10
Durable Line - Pages 24 & 25	Quote	Quote
'EX' Shapes, Pages 38 – 40	5	7
Xtreme Punch - Pages 8 – 11	3	10
Center Dowel - Pages 12 & 13	3	10
Specials	Quote	Quote
Coatings - Page 46	Add 5 Days	Add 5 Days
Locating Methods - Pages 44 & 45	Add 0 Days	Add 1 Day
Standard Alterations - Page 42		
Group (1) Below - up to 2 alterations	Add 0 Days	Add 0 Days
Group (2) Below - each alteration	Add 1 Day	Add 2 Days
Group (1) - RL/RT/RH/LPC/LPW/RP/RW/AP/AW & (AB/IB - for Taper Relief Die Matrix)		
Group (2) - PRL/RD/PRT/AR/SK & (AB/IB - for Stepped Relief Die Matrix)		

Allow Additional Time for Multiple Line Item Orders Over 150 Total Pieces Round, or 50 Total Pieces Shape - or Combinations Thereof - Call For Quote

**NOTE: THE DAY OF RECEIPT OF THE ORDER IS NOT CONSIDERED
A WORK DAY**

WILL SHIP TODAY

ORDER MUST BE ENTERED BY NOON E.S.T. - and confirmed by phone

Up to Ø 25 mm body

M2 steel only;

Catalog Rounds - up to 9 pieces with maximum of one alteration

Catalog Shapes - (flat round, oblong, square and rect.) up to 4 pieces/1 alteration

Locking Methods - single and double flats

Items not available for this service

Knob Style Punches

Coatings/Treatments

Dowel Slots/Full Length Body Flats

Durable Line (catalog pages 24 & 25)

Extrusion Line

Pilot Punches over 92 mm "L"

Advise Shipping Method - if not specified will ship FedEx or UPS next day delivery

A.M. or Saturday delivery if available

Additional Cost -

Round items - add 100% to list price (no minimum charge)

Shape items - add 50% to list price (no minimum charge)

WILL SHIP TOMORROW

ORDER MUST BE ENTERED BY NOON E.S.T. - and confirmed by phone

Same limitations as "Will Ship Today", PLUS

Up to 19 piece quantities

Up to three alterations

All locking methods available

Additional Cost - add 25% per line item (no minimum charge)

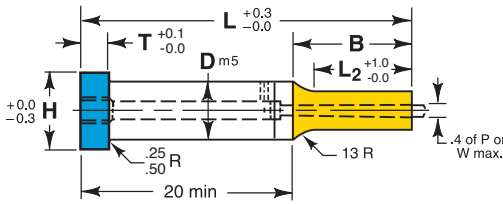

Steel: D2, Rc 58-61,
M2, Rc 60-63, PM4 Rc 63-65
Heads Rc 40-55 25mm Ø and
smaller and L > 50

TOLERANCES

Round P ± 0.01 to -0.00 ◎ 0.01 P to D
Shape P, W ± 0.01 ◎ 0.02 P, W to D

Back Draft 0.1/100mm L2 max.

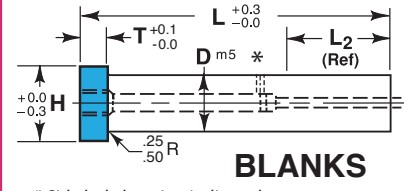

BLANKS

* Side hole location indicated on request

Ordering Example:

Qty Steel Type Code L₂/L P
13 M2 RQ 010 19/080

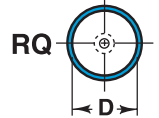

Ordering Example:

Qty Steel Type Code L₂/L P
13 M2 RC 013 19/060 P=10.50

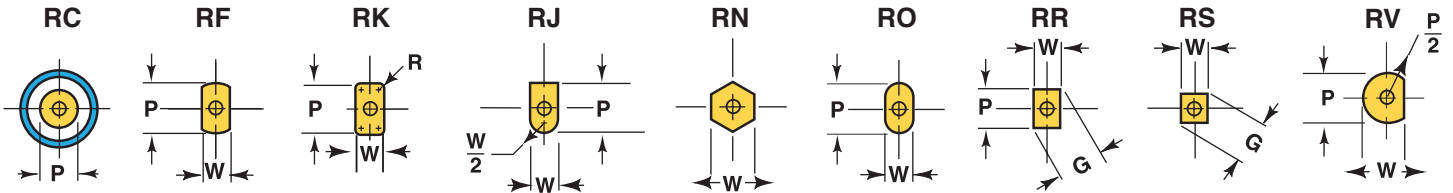

For additional standard forms and configurations see pages 36 - 39.

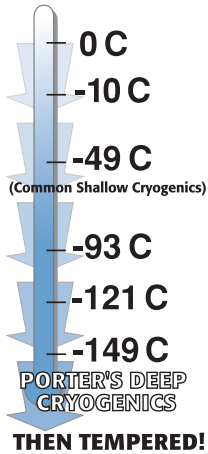

All Standard Punches up to 25mm Dia. are "Deep Cryogenically" treated for
1. Wear
2. Toughness
3. Dimensional Stability

See page 47 for more details.

Reflected View

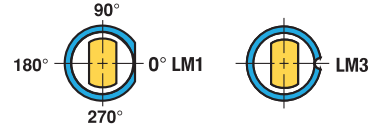

Optional Locating Methods See Page 44 & 45 for details and options.

Shank		Head		L ₂		Lengths L												Point			Replacement		
D mm	Code No.	H	T	Std.	Alt.	045	050	056	060	063	070	071	080	090	100	110	120	125	Round		Shape		Ejector Kit*
																			Range P	MinW	Max P/G		
5	005	8	5	13	19	♦	♦	♦	♦	♦	♦	♦	♦	♦	♦	♦	♦	♦	♦	1.60 – 4.99	1.60	5.00	K2M
6	006	9	5	13	19	♦	♦	♦	♦	♦	♦	♦	♦	♦	♦	♦	♦	♦	♦	2.40 – 5.99	2.40	6.00	K3M
8	008	11	5	19	25	♦	♦	♦	♦	♦	♦	♦	♦	♦	♦	♦	♦	♦	♦	3.20 – 7.99	3.20	8.00	K4M
10	010	13	5	19	25	♦	♦	♦	♦	♦	♦	♦	♦	♦	♦	♦	♦	♦	♦	4.50 – 9.99	4.50	10.00	K6M
13	013	16	5	19	25	♦	♦	♦	♦	♦	♦	♦	♦	♦	♦	♦	♦	♦	♦	6.00 – 12.99	6.00	13.00	K6M
16	016	19	5	19	25	♦	♦	♦	♦	♦	♦	♦	♦	♦	♦	♦	♦	♦	♦	8.00 – 15.99	7.20	16.00	K9M
20	020	23	5	19	25	♦	♦	♦	♦	♦	♦	♦	♦	♦	♦	♦	♦	♦	♦	10.00 – 19.99	8.00	20.00	K9M
25	025	28	5	19	25	♦	♦	♦	♦	♦	♦	♦	♦	♦	♦	♦	♦	♦	♦	12.00 – 24.99	9.00	25.00	K9M
32	032	35	5	25	30					♦	♦	♦	♦	♦	♦	♦	♦	♦	♦	16.00 – 31.99	10.00	32.00	K12M
40	040	43	5	25	30					♦	♦	♦	♦	♦	♦	♦	♦	♦	♦	20.00 – 39.99	10.00	40.00	K12M
45	045	48	5	25	30					♦	♦	♦	♦	♦	♦	♦	♦	♦	♦	25.00 – 44.99	10.00	45.00	K12M
50	050	53	5	25	30					♦	♦	♦	♦	♦	♦	♦	♦	♦	♦	30.00 – 49.99	10.00	50.00	K12M

♦ Only available in Standard Point Length.
♦ ♦ Also available in D2 & PM4

*Ejector Kits available see page 41 for details
5 mm Ø + 32 mm Ø + larger = no side hole.

All Lengths in Light Blue Panel have Hot Forged Heads for added strength and toughness.

Standard Alterations are changes that are beyond the ranges listed in the catalog that can be altered for a minimal charge. See page 42.

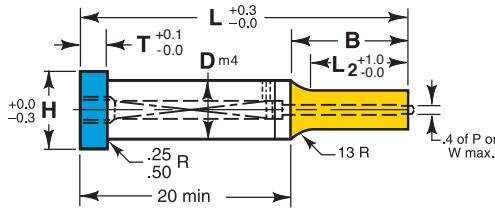

Steel: D2 Rc 58-61, M2 Rc 60-63, PM4, Rc 63-65
 Heads Rc 40-55 (25mm Ø and smaller and L > 50)
TOLERANCES
 Round P $+0.005$ -0.000 $\text{Ⓞ} .008$ P,W to D
 Shape P,W $+0.005$ -0.000 $\text{Ⓞ} .008$ P,W to D

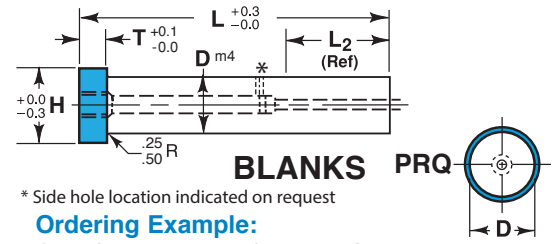

Ordering Example:
 Qty Steel Type Code L₂/L P
 13 M2 PRC 013 19/60 P=10.50

BLANKS PRQ
 Qty Steel Type Code L₂/L
 13 M2 PRQ 010 19/80

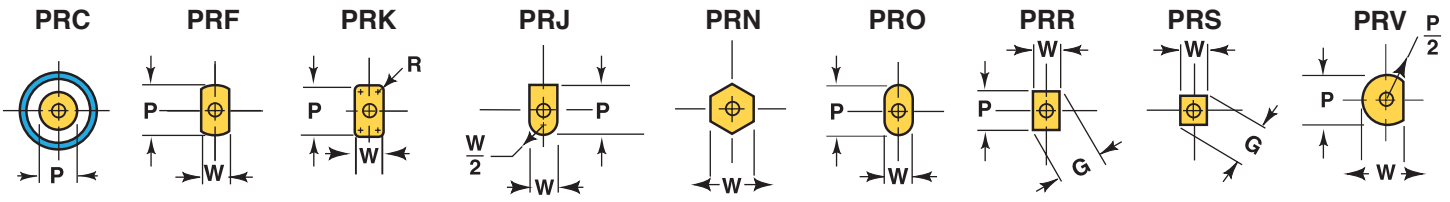

For additional standard forms and configurations see pages 36 - 39.

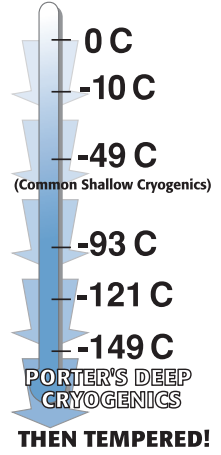

All Ultra Precision Punches up to 25mm Dia. are "Deep Cryogenically" treated for:
 1. Wear
 2. Toughness
 3. Dimensional Stability

See page 47 for more details.

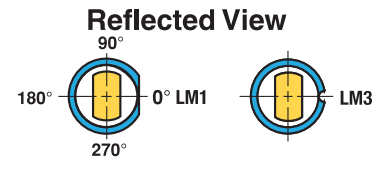

Optional Locating Methods See Page 44 & 45 for details and options.

Shank		Head		L ₂				Lengths L												Point			Replacement Ejector Kit*		
D mm	Code No.	H	T	08	13	19	25	045	050	056	060	063	070	071	080	090	100	110	120	125	Range P	Min W		Max P/G	
5	005	8	5	•	•	•		♦	•	•	•	•	•	•	•	•						1.60 - 4.99	1.60	5.00	K2M
6	006	9	5	•	•	•	•	♦	•	•	•	•	•	•	•	•	•					2.40 - 5.99	2.40	6.00	K3M
8	008	11	5		•	•	•	♦	•	•	•	•	•	•	•	•	•					3.20 - 7.99	3.20	8.00	K4M
10	010	13	5		•	•	•	♦	•	•	•	•	•	•	•	•	•			•		4.50 - 9.99	4.50	10.00	K6M
13	013	16	5		•	•	•		♦	•	•	•	•	•	•	•	•			•		6.00 - 12.99	6.00	13.00	K6M
16	016	19	5		•	•	•			♦	•	•	•	•	•	•	•			•		8.00 - 15.99	7.20	16.00	K9M
20	020	23	5		•	•	•				♦	•	•	•	•	•	•					9.50 - 19.99	8.00	20.00	K9M
25	025	28	5		•	•	•					♦	•	•	•	•	•					12.00 - 24.99	9.00	25.00	K9M
32	032	35	5											•	•	•	•					16.00 - 31.99	10.00	32.00	K12M

♦ L₂ = 19 max. *Ejector Kits available see page 41 for details
 ♦ • Also available in D2 & PM4 5 mm Ø & 32 mm Ø = no side hole.

All Lengths in Light Blue Panel have Hot Forged Heads for added strength and toughness.

Standard Alterations are changes that are beyond the ranges listed in the catalog that can be altered for a minimal charge. See page 42.

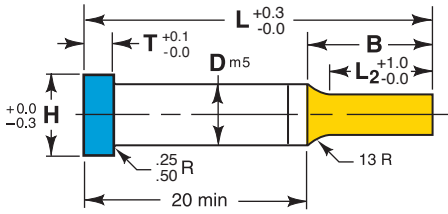

Steel: D2, Rc 58-61,
M2, Rc 60-63, PM4 RC 63-65
Heads Rc 40-55 25mm Ø and
smaller and L > 50

TOLERANCES

Round P $\begin{matrix} +0.01 \\ -0.00 \end{matrix}$ ◎ 0.01 P to D
Shape P, W ± 0.01 ◎ 0.02 P, W to D

Back Draft 0.1/100mm L₂ max.

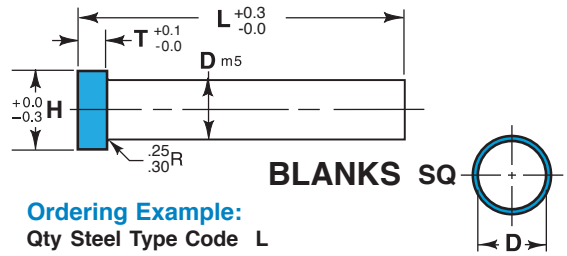

Ordering Example:

Qty Steel Type Code L
25 M2 SQ 008 056

Ordering Example:

Qty Steel Type Code L₂/L P W Locate
25 M2 SO 013 25/090 P=12.00 W=6.00 LM2

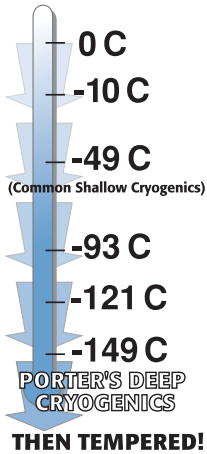
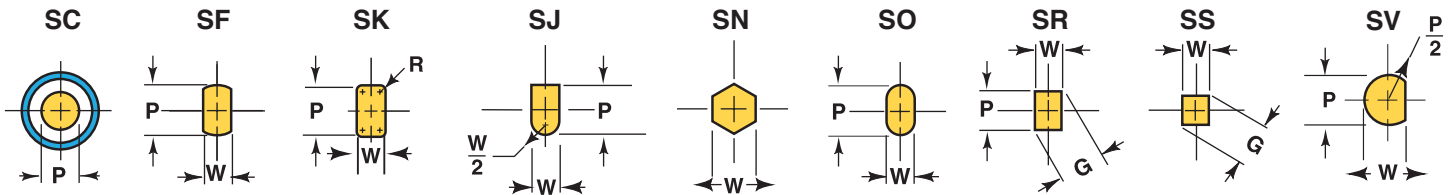

All Standard Punches up to 25mm Dia. are "Deep Cryogenically" treated for:
1. Wear
2. Toughness
3. Dimensional Stability

See page 47 for more details.

For additional standard forms and configurations see pages 36 - 39.

Reflected View

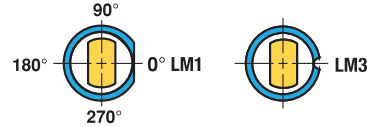

Optional Locating Methods See Page 44 & 45 details and options.

Shank		Head		L ₂		Lengths L											Point				
D mm	Code No.	H	T	Std.	Alt.	045	050	056	060	063	070	071	080	090	100	110	125	150	Round Range P	Shape Min W	Max P/G
4	004	7	5	08	13	•	•	•	•	•	•	•	•	•	•	•			1.60 – 3.99	1.60	4.00
5	005	8	5	13	19	♦	•	•	•	•	•	•	•	•	•	•			1.60 – 4.99	1.60	5.00
6	006	9	5	13	19	♦	•	•	•	•	•	•	•	•	•	•			1.60 – 5.99	1.60	6.00
8	008	11	5	19	25		♦	•	•	•	•	•	•	•	•	•			2.50 – 7.99	2.50	8.00
10	010	13	5	19	25		♦	•	•	•	•	•	•	•	•	•	•	•	3.20 – 9.99	3.20	10.00
13	013	16	5	19	25		♦	•	•	•	•	•	•	•	•	•	•	•	5.00 – 12.99	4.50	13.00
16	016	19	5	19	25		♦	•	•	•	•	•	•	•	•	•	•	•	8.00 – 15.99	6.00	16.00
20	020	23	5	19	25		♦	•	•	•	•	•	•	•	•	•	•	•	10.00 – 19.99	8.00	20.00
22	022	25	5	19	25		♦	•	•	•	•	•	•	•	•	•			11.00 – 21.99	8.50	22.00
25	025	28	5	19	25		♦	•	•	•	•	•	•	•	•	•			12.00 – 24.99	9.00	25.00
32	032	35	5	25	30					•	•	•	•	•	•	•			16.00 – 31.99	10.00	32.00
40	040	43	5	25	30					•	•	•	•	•	•	•			20.00 – 39.99	10.00	40.00
45	045	48	5	25	30					•	•	•	•	•	•	•			25.00 – 44.99	10.00	45.00
50	050	53	5	25	30					•	•	•	•	•	•	•			30.00 – 49.99	10.00	50.00

♦ Only available in Standard Point Length.
• Also available in D2 & PM4

All Lengths in Light Blue Panel have Hot Forged Heads for added strength and toughness.

Standard Alterations are changes that are beyond the ranges listed in the catalog that can be altered for a minimal charge. See page 42.

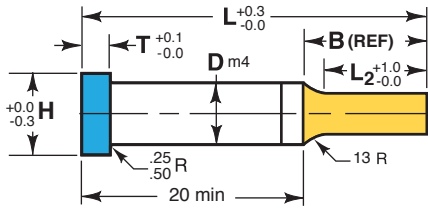

Steel: D2, Rc 58-61, M2 Rc 60-63
 PM4, Rc 63-65
 Heads Rc 40-55 (25mm Ø and smaller and L > 50)

TOLERANCES

Round P $+0.005$ -0.000 $\text{Ⓢ} .008$ P,W to D
 Shape P,W $+0.005$ -0.000 $\text{Ⓢ} .008$ P,W to D

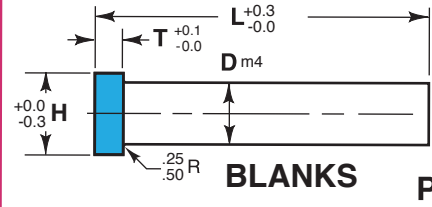

BLANKS

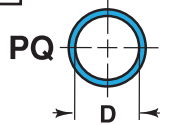

Ordering Example:

Qty Steel Type Code L₂/L P W Locate
 13 PM4 PS 013 19/071 P=5.50 W=5.50 LM2

Ordering Example:

Qty Steel Type Code L
 25 PM4 PQ 020 100

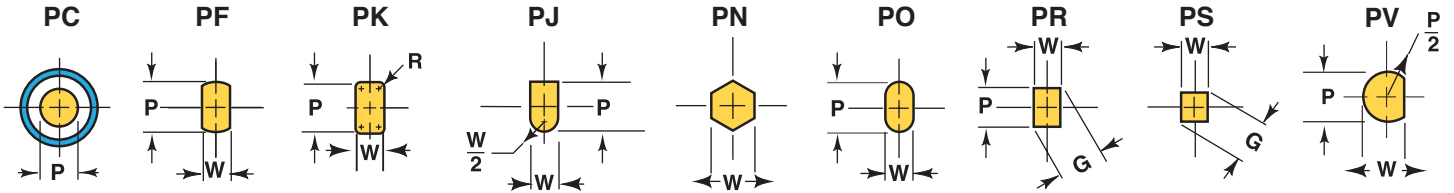

For additional standard forms and configurations see pages 36 - 39.

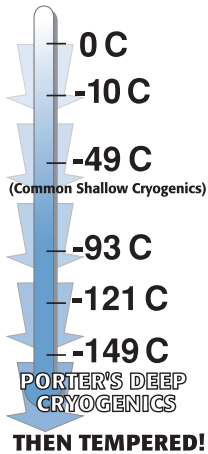

All Ultra Precision Punches up to 25mm Dia. are "Deep Cryogenically" treated for
 1. Wear
 2. Toughness
 3. Dimensional Stability

See page 47 for more details.

Reflected View

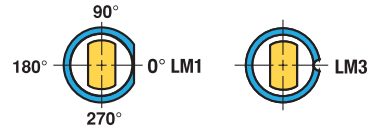

Optional Locating Methods See Page 44 & 45 for details and options.

Shank		Head		L ₂				Lengths L												Range P	Min W	Max P/G		
D mm	Code No.	H	T	08	13	19	25	045	050	056	060	063	070	071	080	090	100	110	125				150	
4	004	7	5	•	•	•	•	•	•	•	•	•	•	•	•	•	•	•	•	•	•	1.00 – 3.99	1.60	4.00
5	005	8	5	•	•	•	•	•	•	•	•	•	•	•	•	•	•	•	•	•	•	1.20 – 4.99	1.60	5.00
6	006	9	5	•	•	•	•	•	•	•	•	•	•	•	•	•	•	•	•	•	•	1.60 – 5.99	1.60	6.00
8	008	11	5	•	•	•	•	•	•	•	•	•	•	•	•	•	•	•	•	•	•	2.50 – 7.99	2.50	8.00
10	010	13	5	•	•	•	•	•	•	•	•	•	•	•	•	•	•	•	•	•	•	3.20 – 9.99	3.20	10.00
13	013	16	5	•	•	•	•	•	•	•	•	•	•	•	•	•	•	•	•	•	•	5.00 – 12.99	4.50	13.00
16	016	19	5	•	•	•	•	•	•	•	•	•	•	•	•	•	•	•	•	•	•	8.00 – 15.99	6.00	16.00
20	020	23	5	•	•	•	•	•	•	•	•	•	•	•	•	•	•	•	•	•	•	9.00 – 19.99	8.00	20.00
22	022	25	5	•	•	•	•	•	•	•	•	•	•	•	•	•	•	•	•	•	•	10.00 – 21.99	8.50	22.00
25	025	28	5	•	•	•	•	•	•	•	•	•	•	•	•	•	•	•	•	•	•	12.00 – 24.99	9.00	25.00
32	032	35	5	•	•	•	•	•	•	•	•	•	•	•	•	•	•	•	•	•	•	16.00 – 31.99	10.00	32.00

(P,W below 1.60 L₂ = 8 max.) P,W below 2.50 L₂ = 19 max.

• Also available in D2 & PM4

All Lengths in Light Blue Panel have Hot Forged Heads for added strength and toughness.

Standard Alterations are changes that are beyond the ranges listed in the catalog that can be altered for a minimal charge. See page 42.

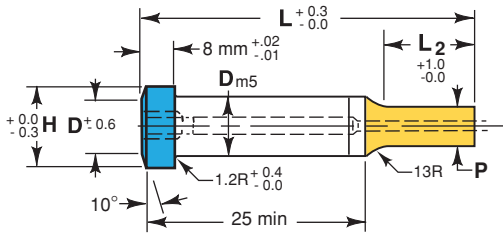

Ordering Example: Qty Type Code L₂/L P
8 XRC 013 13/080 P=6.90

Steel:
M2, Rc 60-63, PM4 Rc 60-63

TOLERANCES

Round P $\begin{matrix} +0.01 \\ -0.00 \end{matrix}$ Ⓞ 0.01 P to D

Shape P, W ± 0.01 Ⓞ 0.02 P, W to D

Back Draft 0.1/100mm L₂ max.

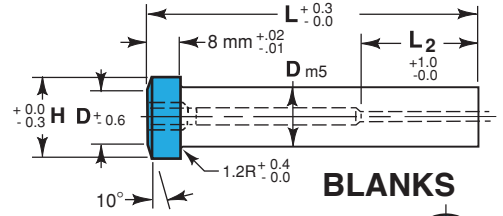

Ordering Example:
Qty Type Code L₂/L
8 XRQ 013 13/080

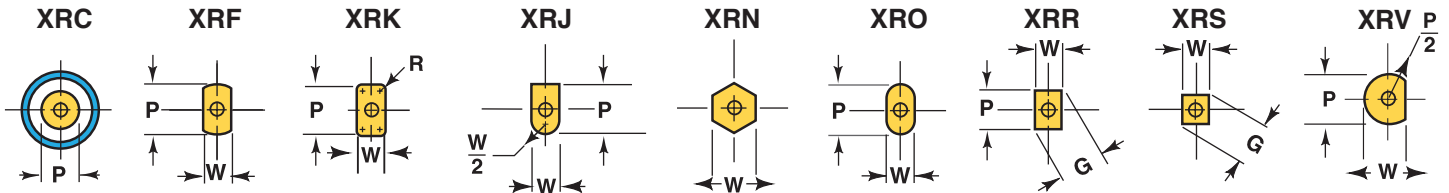
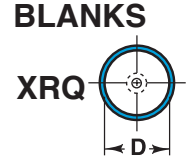

For additional standard forms and configurations see pages 36 - 39.

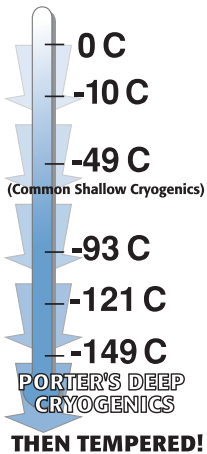

All Porter Xtreme Punches are "Deep Cryogenically" treated for

1. Wear
2. Toughness
3. Dimensional Stability

See page 47 for more details.

THEN TEMPERED!

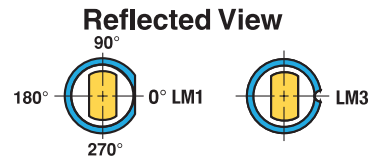

Optional Locating Methods See Page 44 & 45 for details and options.

Shank		Head H mm	Point Length L ₂		Lengths L					Round Point Range P	Shapes		Replacement Ejector Kit*
D mm	Code No.		Std	Alt	060	070	080	090	100		Min W	Max P/G	
8	008	13	13	19	●	●	●	●	●	4.00 - 7.99	4.00	8.00	K4M
10	010	15	13	19	●	●	●	●	●	5.00 - 9.99	5.00	10.00	K6M
13	013	18	13	19	●	●	●	●	●	6.00 - 12.99	6.00	13.00	K6M
16	016	21	19	25	●	●	●	●	●	10.00 - 15.99	6.00	16.00	K9M
20	020	25	19	25	●	●	●	●	●	13.00 - 19.99	6.00	20.00	K9M
25	025	30	19	25	●	●	●	●	●	18.00 - 24.99	6.00	25.00	K9M

*Ejector Kits available see page 41 for details

Standard Alterations are changes that are beyond the ranges listed in the catalog that can be altered for a minimal charge. See page 42.

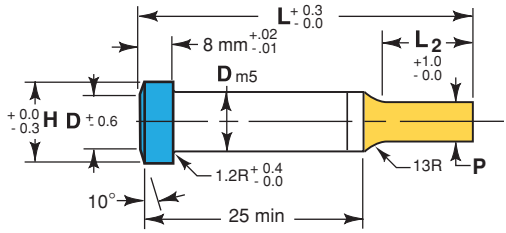

Steel:
M2, Rc 60-63, PM4 RC 60-63

TOLERANCES

Round P $\begin{matrix} +0.01 \\ -0.00 \end{matrix}$ ◎ 0.01 P to D

Shape P, W ± 0.01 ◎ 0.02 P,W to D

Back Draft 0.1/100mm L2 max.

Ordering Example:

Qty Type Code L₂/L P W
12 XSO 020 19/090 P=15.00 W=8.50

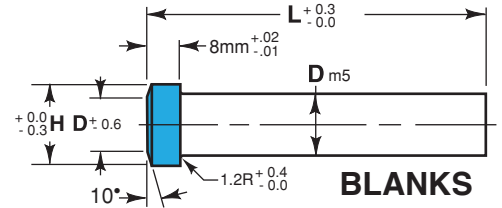

BLANKS

Ordering Example:

Qty Steel Type Code L
25 M2 XSQ 008 060

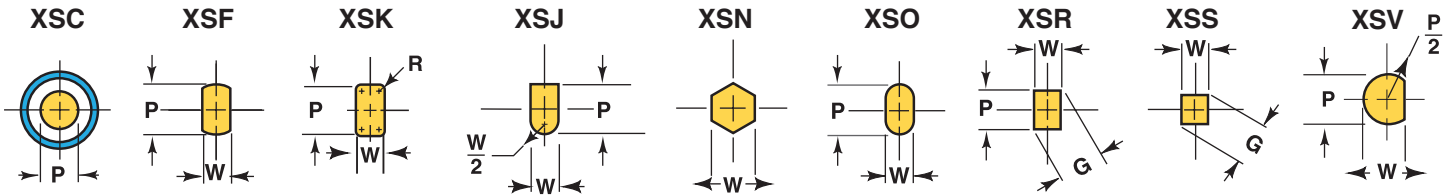
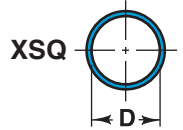

For additional standard forms and configurations see pages 36 - 39.

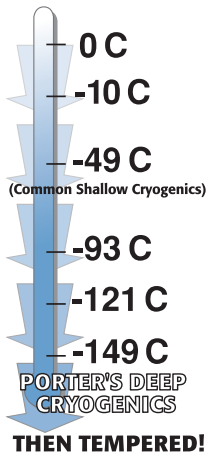

All Porter Extreme Punches are "Deep Cryogenically" treated for

1. Wear
2. Toughness
3. Dimensional Stability

See page 47 for more details.

THEN TEMPERED!

Reflected View

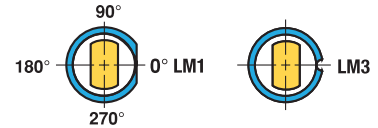

Optional Locating Methods See Page 44 & 45 for details and options.

Shank D mm	Head Code No.	Head H mm	Point Length L ₂		Lengths L					Round Point Range P	Shapes	
			Std	Alt	060	070	080	090	100		Min. W	Max P/G
8	008	13	13	19	●	●	●	●	●	3.00 – 7.99	3.00	8.00
10	010	15	13	19	●	●	●	●	●	3.00 – 9.99	3.00	10.00
13	013	18	13	19	●	●	●	●	●	6.00 – 12.99	3.00	13.00
16	016	21	19	25	●	●	●	●	●	10.00 – 15.99	4.00	16.00
20	020	25	19	25	●	●	●	●	●	13.00 – 19.99	5.00	20.00
25	025	30	19	25	●	●	●	●	●	18.00 – 24.99	6.00	25.00

Standard Alterations are changes that are beyond the ranges listed in the catalog that can be altered for a minimal charge. See page 42.

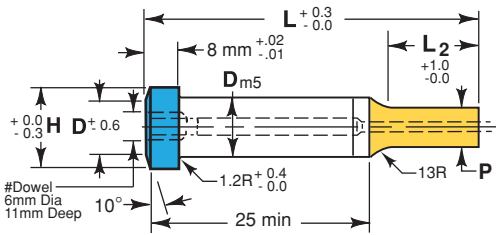

Steel: PM4 Rc 60-63
 Heads Rc 40-55
TOLERANCES
 Round P $+0.01$ -0.00 ◎ 0.01 P to D
 Shape P, W ± 0.01 ◎ 0.02 P,W to D
 Back Draft 0.1/100mm L2 max.

Ordering Example:

Qty	Type	Code	L2/L	P
8	CDXRC	013	13/080	P=6.90

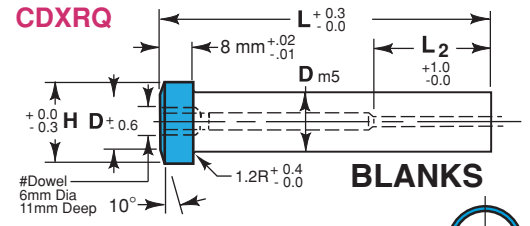

Ordering Example:

Qty	Type	Code	L2/L
13	CDXRQ	010	19/080

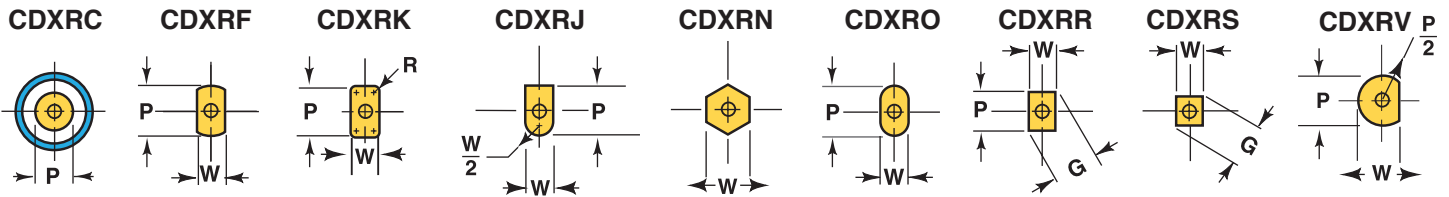
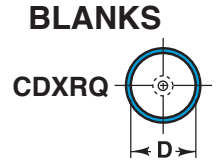

For additional standard forms and configurations see pages 36 - 39.

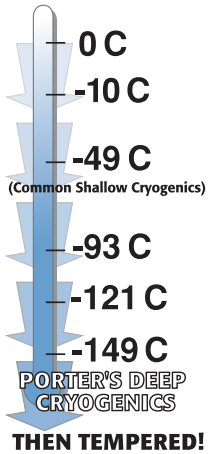

All Porter Xtreme Punches are "Deep Cryogenically" treated for:
 1. Wear
 2. Toughness
 3. Dimensional Stability
 See page 47 for more details.

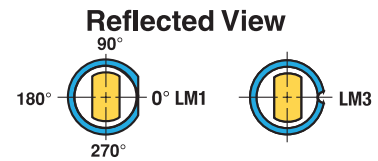

Optional Locating Methods See Page 44 & 45 for details and options.

Shank		Head H mm	Point Length L2		Lengths L			Round Point Range P	Shapes		Replacement Ejector Kit*
D mm	Code No.		Std	Alt	080	090	100		Min W	Max P/G	
10	010	15	13	19	●	●	●	5.00 - 9.99	5.00	10.00	K6M
13	013	18	13	19	●	●	●	6.00 - 12.99	6.00	13.00	K6M
16	016	21	19	25	●	●	●	10.00 - 15.99	6.00	16.00	K9M
20	020	25	19	25	●	●	●	13.00 - 19.99	6.00	20.00	K9M
25	025	30	19	25	●	●	●	18.00 - 24.99	6.00	25.00	K9M

*Ejector Kits available see page 41 for details.

*Standard dowel supplied. Pull dowel available upon request.

Standard Alterations are changes that are beyond the ranges listed in the catalog that can be altered for a minimal charge. See page 42.

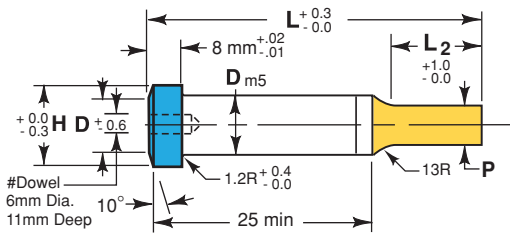

Steel: PM4 Rc 60-63
Heads Rc 40-55

TOLERANCES

Round P $+0.01$ to -0.00 ◎ 0.01 P to D

Shape P, W ± 0.01 ◎ 0.02 P, W to D

Back Draft 0.1/100mm L₂ max.

Ordering Example:

Qty	Type	Code	L ₂ /L	P	W
12	CDXS	020	19/080	P=15.00	W=8.50

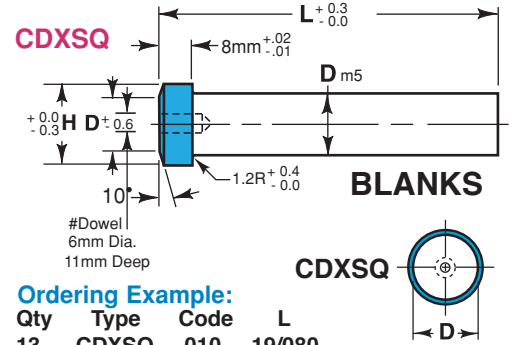

Ordering Example:

Qty	Type	Code	L
13	CDXSQ	010	19/080

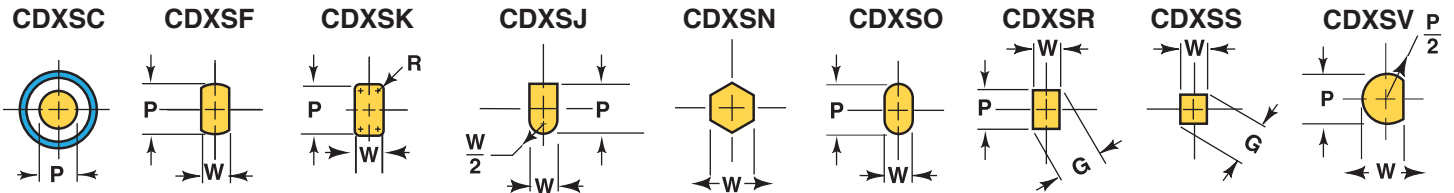

For additional standard forms and configurations see pages 36 - 39.

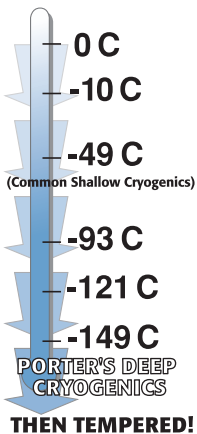

All Xtreme Punches are "Deep Cryogenically" treated for

1. Wear
2. Toughness
3. Dimensional Stability

See page 47 for more details.

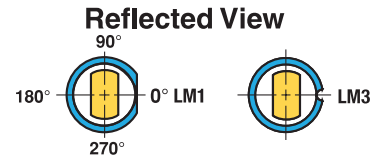

Optional Locating Methods See Page 44 & 45 for details and options.

Shank		Head H mm	Point Length L ₂		Lengths L			Round Point Range P	Shapes	
D mm	Code No.		Std	Alt	80	90	100		Min. W	Max P/G
10	010	15	13	19	●	●	●	3.00 - 9.99	3.00	10.00
13	013	18	13	19	●	●	●	6.00 - 12.99	3.00	13.00
16	016	21	19	25	●	●	●	10.00 - 15.99	4.00	16.00
20	020	25	19	25	●	●	●	13.00 - 19.99	5.00	20.00
25	025	30	19	25	●	●	●	18.00 - 24.99	6.00	25.00

#Standard dowel supplied. Pull dowel available upon request

Standard Alterations are changes that are beyond the ranges listed in the catalog that can be altered for a minimal charge. See page 42.

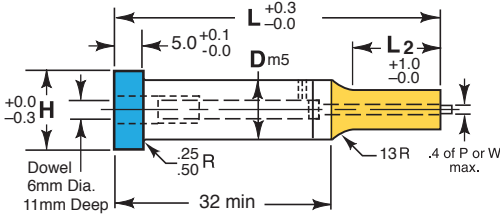

Steel: M2 Rc 60-63
Heads Rc 40-55 (25 mm Ø and smaller)
TOLERANCES
 Round P $\begin{matrix} +0.01 \\ -0.00 \end{matrix}$ ⊙ 0.01 P to D
 Shape P, W ± 0.01 ⊙ 0.02 P,W to D
 Back Draft 0.1/100mm L2 max.

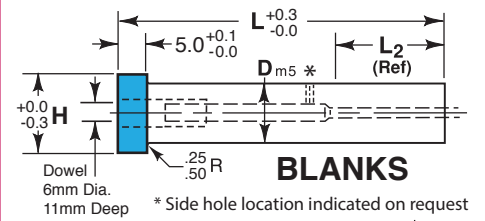

Ordering Example:

Qty Steel Type Code L₂/L P W
 25 M2 CDRO 010 25/090 P=8.50 W=5.00

Ordering Example:

Qty Steel Type Code L₂/L
 25 M2 CDRQ 025 19/090

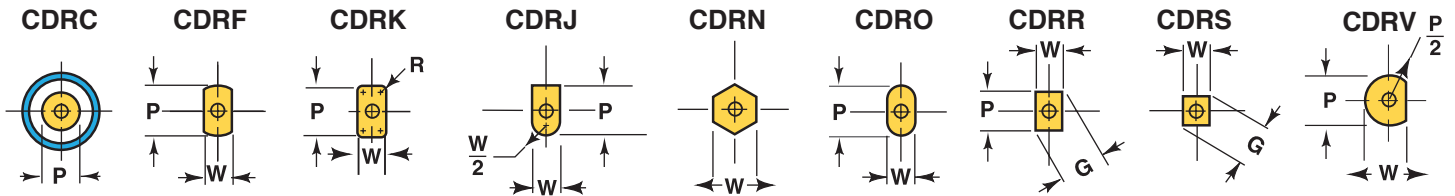

For additional standard forms and configurations see pages 36 - 39.

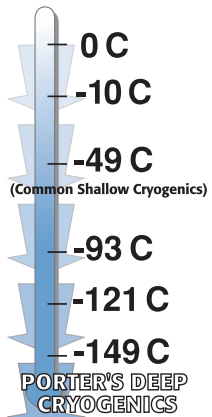

All Standard Center Dowel Punches "Deep Cryogenically" treated for:
 1. Wear
 2. Toughness
 3. Dimensional Stability

See page 47 for more details.

THEN TEMPERED!

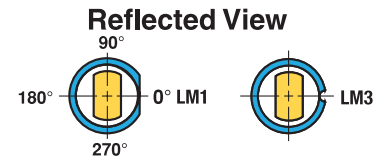

Optional Locating Methods See Page 44 & 45 for details and options.

D mm	Code No.	Head H mm	Point Length L ₂		Lengths L				Round Point Range P	Shapes		Replacement Ejector Kit*
			Std	Alt	071	080	090	100		Min W	Max P/G	
10	010	13	19	25	●	●	●	●	4.50 - 9.99	4.50	10.00	K6M
13	013	16	19	25	●	●	●	●	6.00 - 12.99	6.00	13.00	K6M
16	016	19	19	25	●	●	●	●	8.00 - 15.99	7.20	16.00	K9M
20	020	23	19	25	●	●	●	●	10.00 - 19.99	8.00	20.00	K9M
25	025	28	19	25	●	●	●	●	12.00 - 24.99	9.00	25.00	K9M
32	032	35	25	30	●	●	●	●	16.00 - 31.99	10.00	32.00	K9M

*Ejector Kits available see Page 41 for details.

32 mm Ø = no side hole.

All Lengths in Light Blue Panel have Hot Forged Heads for added strength and toughness.

Standard Alterations are changes that are beyond the ranges listed in the catalog that can be altered for a minimal charge. See page 42.

PORTER® Standard Center Dowel Punches (CDS-)

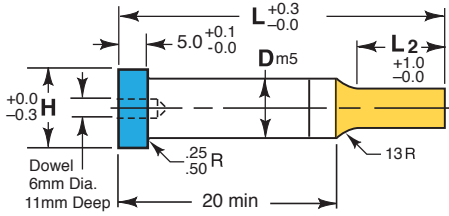

Steel: M2 Rc 60-63
Heads Rc 40-55 (25 mm Ø and smaller)
TOLERANCES
 Round P $\begin{matrix} +0.01 \\ -0.00 \end{matrix}$ ⊙ 0.01 P to D
 Shape P, W ± 0.01 ⊙ 0.02 P,W to D
 Back Draft 0.1/100mm L2 max.

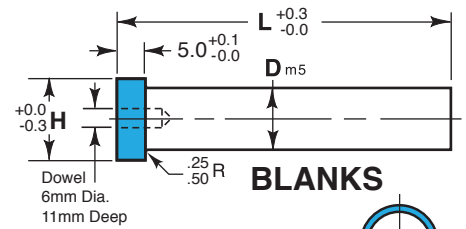

BLANKS

Ordering Example:

Qty Steel Type Code L₂/L P
 50 M2 CDSC 016 19/090 P=10.00

Ordering Example:

Qty Steel Type Code L
 12 M2 CDSQ 032 100



CDSC



CDSF

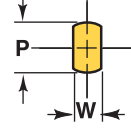

CDSK

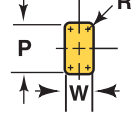

CDSJ

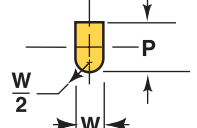

CDSN

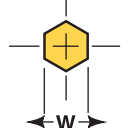

CDSO

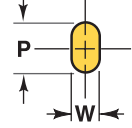

CDSR

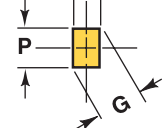

CDSS

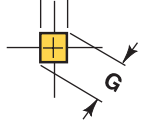

CDSV $\frac{P}{2}$

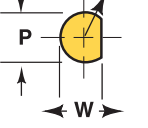

For additional standard forms and configurations see pages 36 - 39.

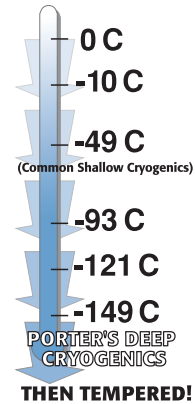

All Standard Center Dowel Punches up to 25mm Dia. are "Deep Cryogenically" treated for
 1. Wear
 2. Toughness
 3. Dimensional Stability

See page 47 for more details.

Reflected View

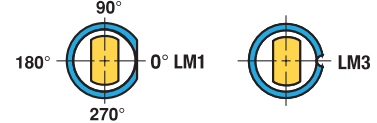

Optional Locating Methods See Page 44 & 45 for details and options.

Shank		Head H mm	Point Length L ₂		Lengths L										Round Point Range P	Shapes	
D mm	Code No.		Std	Alt	071	080	090	100	110	125	130	140	150	Min W		Max P/G	
10	010	13	19	25	•	•	•	•	•	•	•	•	•	•	4.50 - 9.99	4.50	10.00
13	013	16	19	25	•	•	•	•	•	•	•	•	•	•	6.00 - 12.99	6.00	13.00
16	016	19	19	25	•	•	•	•	•	•	•	•	•	•	8.00 - 15.99	7.20	16.00
20	020	23	19	25	•	•	•	•	•	•	•	•	•	•	10.00 - 19.99	8.00	20.00
25	025	28	19	25	•	•	•	•	•	•	•	•	•	•	12.00 - 24.99	9.00	25.00
32	032	35	25	30	•	•	•	•	•	•	•	•	•	•	16.00 - 31.99	10.00	32.00
38	038	41	25	30	•	•	•	•	•	•	•	•	•	•	16.00 - 37.99	10.00	38.00

PORTER® Standard Center Dowel Pilot Punches (CDSAP)

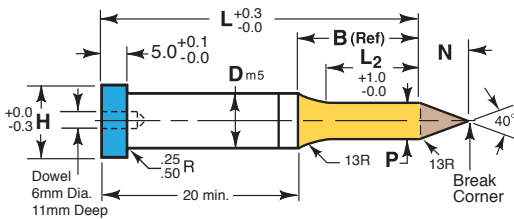

B & L Lengths do not include Pilot Tip N

Ordering Example:

Qty Steel Type Code L₂/L P
 25 M2 CDSAP 013 21/065 P=12.00

Standard Alterations are changes that are beyond the ranges listed in the catalog that can be altered for a minimal charge. See page 42.

Shank		Head H mm	Point Length L ₂		Standard Lengths L								Standard Point Range	N MAX	
D mm	Catalog No.		Std	Alt	065	073	082	092	102	112	127	132			142
10	CDSAP10	13	21	27	•	•	•	•	•	•	•	•	•	4.85 - 10.00	8
13	CDSAP13	16	21	27	•	•	•	•	•	•	•	•	•	6.30 - 13.00	10
16	CDSAP16	19	21	27	•	•	•	•	•	•	•	•	•	9.95 - 16.00	15
20	CDSAP20	23	21	27	•	•	•	•	•	•	•	•	•	13.60 - 20.00	20
25	CDSAP25	28	21	27	•	•	•	•	•	•	•	•	•	17.25 - 25.00	25
32	CDSAP32	35	27	32	•	•	•	•	•	•	•	•	•	20.85 - 32.00	30

All Lengths in Light Blue Panel have Hot Forged Heads for added strength and toughness.

• Available D2 only RC 58-61

Regular Parabolic Pilot-SP Type

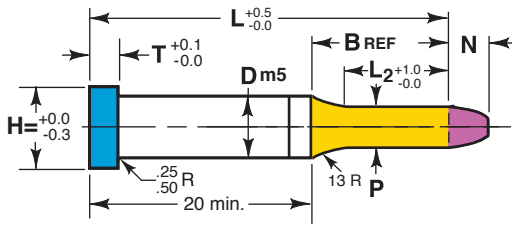

B & L Lengths do not include Pilot Tip N

Ordering Example: Qty Steel Type Code L₂/L P
 13 M2 SP 010 21/082 P=7.55

Steel: D2, Rc 58-61
 M2 Rc 60-63 PM4, Rc 63-65
 Heads Rc 40-55 (25mm Ø and smaller and L > 50)

TOLERANCES

Round P $\begin{matrix} +0.01 \\ -0.00 \end{matrix}$ $\begin{matrix} \text{©} \\ \text{0.01} \end{matrix}$ P to D

Headless Punch Pilots are also available.
 To order call out: **Regular Pilot = HSP**
Angular Pilot = HAP

Shank		Head		L ₂		Lengths L										N	Round	
D	Pilot Type	H	T	Std	Alt	047	052	058	062	072	073	082	092	102	112	127	MAX	Range P
4	SP004	7	5	10	15	♦	♦	♦	♦	♦	♦	♦	♦				4.0	1.55 – 4.00
5	SP005	8	5	15	21	♦	♦	♦	♦	♦	♦	♦	♦				4.0	1.55 – 5.00
6	SP006	9	5	15	21	♦	♦	♦	♦	♦	♦	♦	♦				4.0	2.45 – 6.00
8	SP008	11	5	21	27		♦	♦	♦	♦	♦	♦	♦	•	•		4.0	3.15 – 8.00
10	SP010	13	5	21	27		♦	♦	♦	♦	♦	♦	♦	•	•	•	4.0	4.45 – 10.00
13	SP013	16	5	21	27		♦	♦	♦	♦	♦	♦	♦	•	•	•	4.0	5.95 – 13.00
16	SP016	19	5	21	27		♦	♦	♦	♦	♦	♦	♦	•	•	•	4.0	7.95 – 16.00
20	SP020	23	5	21	27		♦	♦	♦	♦	♦	♦	♦	•	•	•	4.0	9.95 – 20.00
25	SP025	28	5	21	27		♦	♦	♦	♦	♦	♦	♦	•			4.0	12.00 – 25.00
32	SP032	35	5	27	32					•	•	•	•	•			4.0	16.00 – 32.00

- ♦ Only available in Standard Point length
- ♦♦ Also available in D2 & PM4

All Lengths in Light Blue Panel have Hot Forged Heads for added strength and toughness.

Angular Pilot-SAP Type

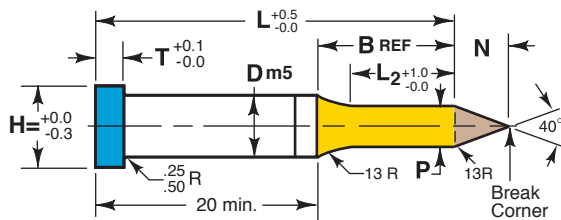

B & L Lengths do not include Pilot Tip N

Ordering Example: Qty Steel Type Code L₂/L P
 6 M2 SAP 025 27/102 P=20.05

Shank		Head		L ₂		Lengths L							N	Round	
D	Pilot Type	H	T	Std	Alt	065	072	073	082	092	102	112	127	MAX	Range P
8	SAP008	11	5	21	27	♦	♦	♦	♦	♦	•	•		7	2.45 – 8.00
10	SAP010	13	5	21	27	♦	♦	♦	♦	♦	•	•	•	8	4.85 – 10.00
13	SAP013	16	5	21	27	♦	♦	♦	♦	♦	•	•	•	10	6.30 – 13.00
16	SAP016	19	5	21	27	♦	♦	♦	♦	♦	•	•	•	15	9.95 – 16.00
20	SAP020	23	5	21	27	♦	♦	♦	♦	♦	•	•	•	20	13.60 – 20.00
25	SAP025	28	5	21	27	♦	♦	♦	♦	♦	•			25	17.25 – 25.00
32	SAP032	35	5	21	32	♦	♦	♦						30	20.85 – 32.00

- ♦ Also available in D2 & PM4

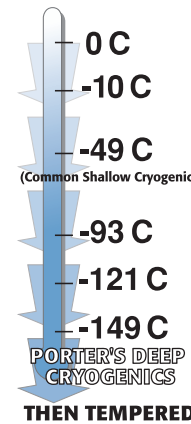

All Standard Punches up to 25mm Dia. are "Deep Cryogenically" treated for

1. Wear
2. Toughness
3. Dimensional Stability

See page 47 for more details.

All Lengths in Light Blue Panel have Hot Forged Heads for added strength and toughness.

Standard Alterations are changes that are beyond the ranges listed in the catalog that can be altered for a minimal charge. See page 42.

Ultra Precision Regular Pilot

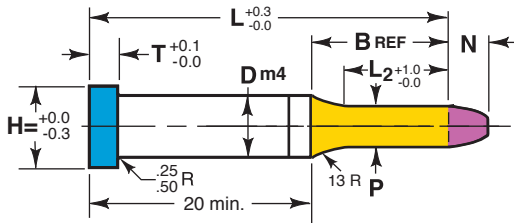

Steel: D2, Rc 58-61,
M2 60-63, PM4, Rc 63-65
Heads Rc 40-55 (25mm Ø and
smaller and L > 50)
TOLERANCES
Round P $\begin{matrix} +0.005 \\ -0.000 \end{matrix}$ © .008 P to D

Headless Punch Pilots are also available.
To order call out: **Regular Pilot = HSP**
Angular Pilot = HAP

B & L Lengths do not include Pilot Tip N

Ordering Example: Qty Steel Type Code L₂/L P
50 M2 PP 004 29/092 P=3.75

Shank		Head		L ₂				Lengths L										N	Round		
D	Pilot Type	H	T	10	15	21	27	047	052	058	062	065	072	073	082	092	102	112	127	MAX	Range P
4	PP004	7	5	●	●	●	●	●	●	●	●	●	●	●	●	●	●	●	●	4.0	1.55 – 4.00
5	PP005	8	5	●	●	●	●	●	●	●	●	●	●	●	●	●	●	●	●	4.0	1.55 – 5.00
6	PP006	9	5	●	●	●	●	●	●	●	●	●	●	●	●	●	●	●	●	4.0	1.55 – 6.00
8	PP008	11	5	●	●	●	●	●	●	●	●	●	●	●	●	●	●	●	●	4.0	2.45 – 8.00
10	PP010	13	5	●	●	●	●	●	●	●	●	●	●	●	●	●	●	●	●	4.0	3.15 – 10.00
13	PP013	16	5	●	●	●	●	●	●	●	●	●	●	●	●	●	●	●	●	4.0	4.95 – 13.00
16	PP016	19	5	●	●	●	●	●	●	●	●	●	●	●	●	●	●	●	●	4.0	7.95 – 16.00
20	PP020	23	5	●	●	●	●	●	●	●	●	●	●	●	●	●	●	●	●	4.0	8.95 – 20.00
22	PP022	25	5	●	●	●	●	●	●	●	●	●	●	●	●	●	●	●	●	4.0	9.95 – 22.00
25	PP025	28	5	●	●	●	●	●	●	●	●	●	●	●	●	●	●	●	●	4.0	11.95 – 25.00
32	PP032	35	5	●	●	●	●	●	●	●	●	●	●	●	●	●	●	●	●	4.0	15.95 – 32.00

All Lengths in Light Blue Panel have Hot Forged Heads for added strength and toughness.

● Also available in D2 & PM4

P below 1.60 L₂ = 10 max

P below 2.50 L₂ = 21 max

Ultra Precision Angular Pilot-PAP Type

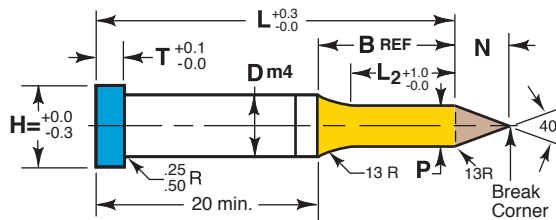

B & L Lengths do not include Pilot Tip N

Ordering Example: Qty Steel Type Code L₂/L P
13 D2 PAP 016 21/062 P=10.50

Shank		Head		L ₂				Lengths L										N	Round
D	Pilot Type	H	T	10	15	21	27	065	072	073	082	092	102	112	127	MAX	Range P		
8	PAP008	11	5	●	●	●	●	●	●	●	●	●	●	●	●	7	2.45 – 8.00		
10	PAP010	13	5	●	●	●	●	●	●	●	●	●	●	●	●	8	4.85 – 10.00		
13	PAP013	16	5	●	●	●	●	●	●	●	●	●	●	●	●	10	6.30 – 13.00		
16	PAP016	19	5	●	●	●	●	●	●	●	●	●	●	●	●	15	9.95 – 16.00		
20	PAP020	23	5	●	●	●	●	●	●	●	●	●	●	●	●	20	13.60 – 20.00		
22	PAP022	25	5	●	●	●	●	●	●	●	●	●	●	●	●	22	15.00 – 22.00		
25	PAP025	28	5	●	●	●	●	●	●	●	●	●	●	●	●	25	17.75 – 25.00		
32	PAP032	35	5	●	●	●	●	●	●	●	●	●	●	●	●	30	20.85 – 32.00		

● Also available in D2 & PM4

P below 1.60 L₂ = 10 max

P below 2.50 L₂ = 21 max

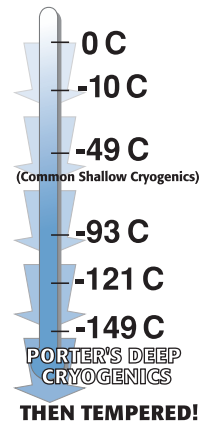

All Ultra Precision Pilots are "Deep Cryogenically" treated for
1. Wear
2. Toughness
3. Dimensional Stability

See page 47 for more details.

All Lengths in Light Blue Panel have Hot Forged Heads for added strength and toughness.

Standard Alterations are changes that are beyond the ranges listed in the catalog that can be altered for a minimal charge. See page 42.

Sur-Align Straight (SAPQ)

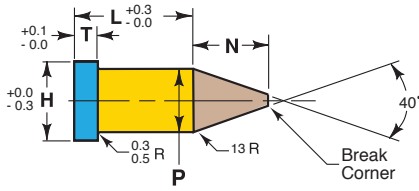

Steel: M2 Rc 60-63
TOLERANCES
 P $+0.01$
 -0.00 Ⓢ 0.01 P to D

Ordering Example: Qty Steel Type Code L P Dim. Alt.
 10 M2 SAPQ 32 5.50 RL=29
 20 M2 SAPN 025 x 25 24.50

Sur-Align Nibbed (SAPN)

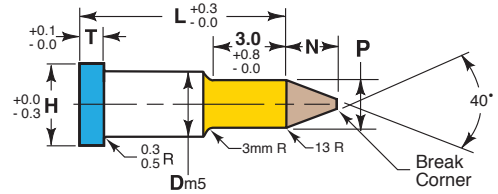

Sur-Align Pilots prevent movement. Reduce standard pilot deflection by mounting Sur-Align in your guide stripper plate.

Type	Range P	Max N	Head		Lengths L							Shank			Min P	Range P	Max N
			T	H	16	20	22	25	28	32	35	Type	D	Code			
SAPQ	3.00 – 4.00	4	5	7	●	●	●	●	●	●	●	SAPN004	4	004	1.55	1.95 – 3.99	4
SAPQ	4.01 – 5.00	5	5	8	●	●	●	●	●	●	●	SAPN005	5	005	1.55	2.65 – 4.99	5
SAPQ	5.01 – 6.00	6	5	9	●	●	●	●	●	●	●	SAPN006	6	006	2.10	3.40 – 5.99	6
SAPQ	6.01 – 8.00	7	5	11	●	●	●	●	●	●	●	SAPN008	8	008	2.10	4.10 – 7.99	7
SAPQ	8.01 – 10.00	8	5	13	●	●	●	●	●	●	●	SAPN010	10	010	2.10	4.85 – 9.99	8
SAPQ	10.01 – 13.00	10	5	16	●	●	●	●	●	●	●	SAPN013	13	013	3.15	6.30 – 12.99	10
SAPQ	13.01 – 16.00	15	5	19	●	●	●	●	●	●	●	SAPN016	16	016	5.95	9.95 – 15.99	15
SAPQ	16.01 – 20.00	20	5	23	●	●	●	●	●	●	●	SAPN020	20	020	5.95	13.60 – 19.99	20
			5	28	●	●	●	●	●	●	●	SAPN025	25	025	7.95	17.25 – 24.99	25
			5	35	●	●	●	●	●	●	●	SAPN032	32	032	9.95	20.85 – 31.99	30

Any overall length within catalog range no extra cost Specify "RL" plus length.

Sur-Align Straight (PAPQ)

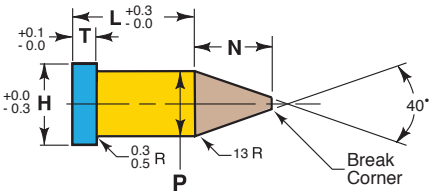

Steel: D2 Rc 58-61, M2 Rc 60-63
 PM4 Rc 63-65
TOLERANCES
 P $+0.005$
 -0.000 Ⓢ 0.008 P to D

Ordering Example: Qty Steel Type L P Alt.
 10 D2 PAPQ 32 P=5.50 RL=29

Sur-Align Nibbed (PAPN)

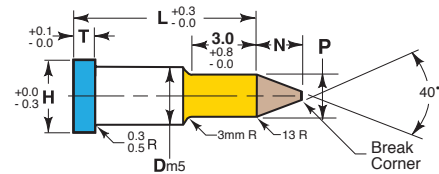

Ordering Example: Qty Steel Type Code L P
 20 M2 PAPN 025 28 P=8.02

Type	Range P	Max N	Head		Lengths L							Shank			Min P	Range P	Max N
			T	H	16	20	22	25	28	32	35	Type	D	Code			
PAPQ	3.00 – 4.00	4	5	7	●	●	●	●	●	●	●	PAPN004	4	004	1.55	1.95 – 3.99	4
PAPQ	4.01 – 5.00	5	5	8	●	●	●	●	●	●	●	PAPN005	5	005	1.55	2.65 – 4.99	5
PAPQ	5.01 – 6.00	6	5	9	●	●	●	●	●	●	●	PAPN006	6	006	2.10	3.40 – 5.99	6
PAPQ	6.01 – 8.00	7	5	11	●	●	●	●	●	●	●	PAPN008	8	008	2.10	4.10 – 7.99	7
PAPQ	8.01 – 10.00	8	5	13	●	●	●	●	●	●	●	PAPN010	10	010	2.10	4.85 – 9.99	8
PAPQ	10.01 – 13.00	10	5	16	●	●	●	●	●	●	●	PAPN013	13	013	3.15	6.30 – 12.99	10
PAPQ	13.01 – 16.00	15	5	19	●	●	●	●	●	●	●	PAPN016	16	016	5.95	9.95 – 15.99	15
PAPQ	16.01 – 20.00	20	5	23	●	●	●	●	●	●	●	PAPN020	20	020	5.95	13.60 – 19.99	20
			5	28	●	●	●	●	●	●	●	PAPN025	25	025	7.95	17.25 – 24.99	25
			5	35	●	●	●	●	●	●	●	PAPN032	32	032	9.95	20.85 – 31.99	30

Any overall length within catalog range no extra cost Specify "RL" plus length.

Standard Alterations are changes that are beyond the ranges listed in the catalog that can be altered for a minimal charge. See page 42.

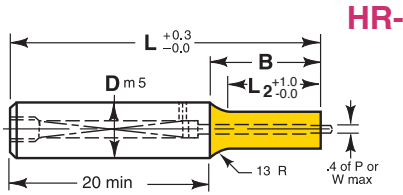

Steel: M2 Rc 60-63

TOLERANCES

Round P $\begin{matrix} +0.01 \\ -0.00 \end{matrix}$ $\text{Ⓢ} 0.01$ P to D

Shape P, W ± 0.01 $\text{Ⓢ} 0.02$ P,W to D

Back Draft 0.1/100mm L2 max.

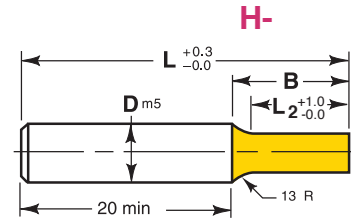

Ordering Example:

Qty Steel Type Code L₂/L P W ALT
15 M2 HRO 020 19/063 P=19.99 W=10.25 AD

Ordering Example:

Qty Steel Type Code L₂/L P
25 M2 HC 013 25/080 P=6.00

HRQ

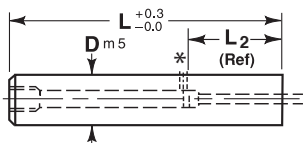

* Side hole location indicated on request

BLANKS

Ordering Example:

Qty Steel Type Code L₂/L
10 M2 HEQ 025 19/070

D=g5 add AD to callout

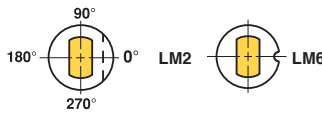

Optional Locating Methods See page 44 & 45 for details and options.

HQ

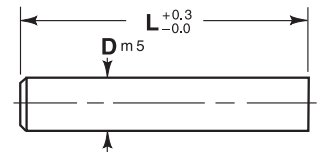

BLANKS

Ordering Example:

Qty Steel Type Code L
12 M2 HQ 013 100

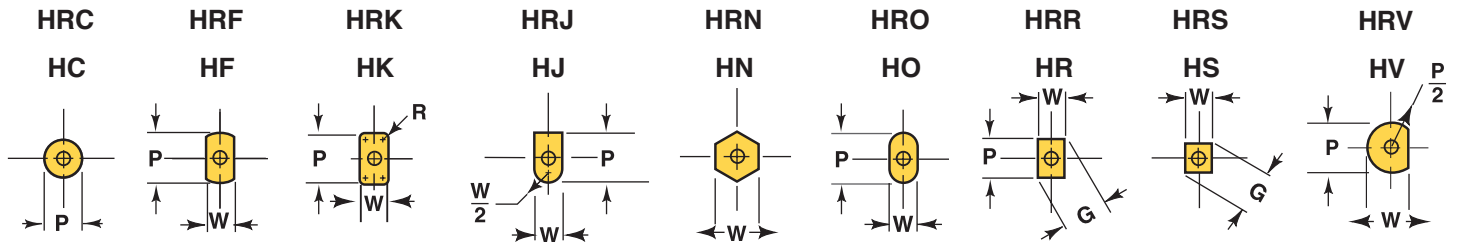

For additional standard forms and configurations see pages 36 - 39.

Shank		L ₂		Lengths L									Point			Replacement Ejector Kit	
D mm	Code No.	Std.	Alt.	045	050	056	060	063	070	071	080	090	100	Round	Shape		
														Range P	Min W		Max P/G
5	005	13	19	◆	•	•	•	•	•	•	•	•	•	1.60 – 4.99	1.60	5.00	K2M
6	006	13	19	◆	•	•	•	•	•	•	•	•	•	2.40 – 5.99	2.40	6.00	K3M
8	008	19	25		◆	•	•	•	•	•	•	•	•	3.20 – 7.99	3.20	8.00	K4M
10	010	19	25		◆	•	•	•	•	•	•	•	•	4.50 – 9.99	4.50	10.00	K6M
13	013	19	25		◆	•	•	•	•	•	•	•	•	6.00 – 12.99	6.00	13.00	K6M
16	016	19	25		◆	•	•	•	•	•	•	•	•	8.00 – 15.99	7.20	16.00	K9M
20	020	19	25		◆	•	•	•	•	•	•	•	•	10.00 – 19.99	8.00	20.00	K9M
25	025	19	25		◆	•	•	•	•	•	•	•	•	12.00 – 24.99	9.00	25.00	K9M

◆ Only available in Standard Point Length. * Ejector Kits available see page 41 for details. 5mm Ø = no side hole.

STD LM-7	
D	A°
≤10mm	5°
13mm	7.5°
≥16mm	10°

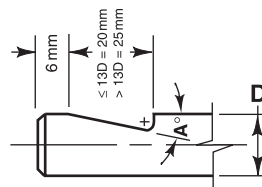

For Shape and Form Headless Punches **Specify LM7** relation to shape. Standard location is at 0°. Alternate angles are available **Specify LM7 A=12°**.

PORTER® Standard Die Button

HND-

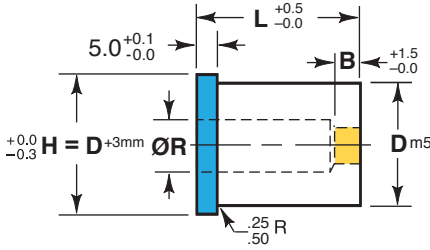

Steel: M2 Rc 60-63

TOLERANCES

Round P	$+0.01$ -0.00	◎ 0.01	P to D
Shape P, W	± 0.01	◎ 0.02	P, W to D

ND-

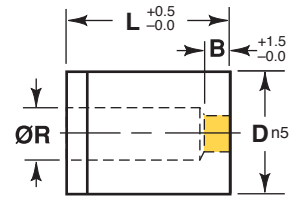

Ordering Example:

Qty Steel Type Code L P
6 M2 HNDC 020 x 25 P=11.00

Ordering Example:

Qty Steel Type Code L P W Locate
6 M2 NDR 016 x 25 P=5.40 W=4.20 LM1

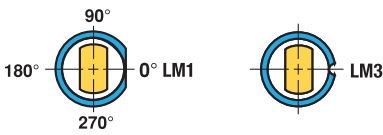

Optional Locating Methods See Page 44 & 45 for details and options.

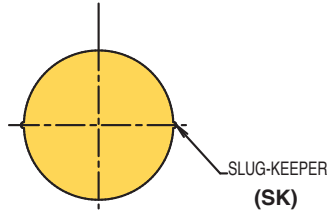

Porter's Slug keeper can be added to any round or shape die to reduce slug pulling



Optional Locating Methods See Page 44 & 45 for details and options.

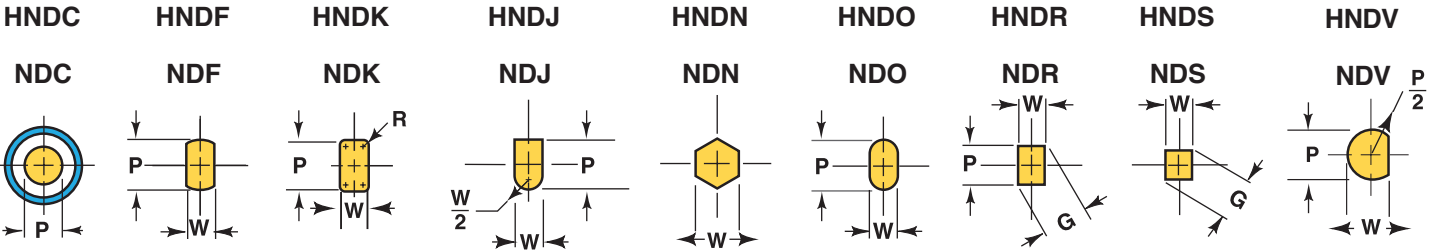

For additional standard forms and configurations see pages 36 - 39.

Body D	Code No.	Land B**	Max. R	Lengths								Round ID		Shape ID	
				19	20	22	25	28	30	32	35	Range P	Min. W	Max. P/G	
8	008	4	4	N	N	N	●	N	●	●	●	1.5 - 3.2	-	-	
10	010	4	6	N	N	N	●	N	●	●	●	1.5 - 5.0	1.5	5.0	
13	013	5	8	N	N	N	●	N	●	●	●	1.5 - 7.2	1.5	7.2	
16	016	5	9.5	N	N	N	●	N	●	●	●	5.0 - 8.8	1.9	8.8	
20	020	5	12	N	N	N	●	N	●	●	●	7.0 - 11.0	1.9	11.0	
22	022	6	15	N	N	N	●	N	●	●	●	9.0 - 14.0	1.9	14.0	
25	025	6	17.5	N	N	N	●	N	●	●	●	11.0 - 16.5	1.9	16.5	
32	032	6	21	N	N	N	●	N	●	●	●	13.0 - 20.0	4.0	20.0	
38	038	8	27		N	N	●	N	●	●	●	16.0 - 26.0	4.0	26.0	

N = Available ND only. **Additional Land lengths available see page 19 (Taper Relief Dies)

Standard Alterations are changes that are beyond the ranges listed in the catalog that can be altered for a minimal charge. See page 42.

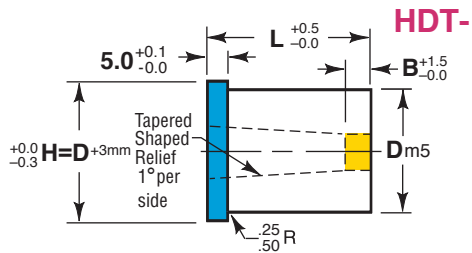

Steel: M2 Rc 60-63,
PM4 Rc 63-65

TOLERANCES

Round P ^{+0.01}/_{-0.00} ◎ 0.01 P to D

Shape P, W ±0.01 ◎ 0.02 P,W to D

(1) ØD > 40 Tol D = m 5

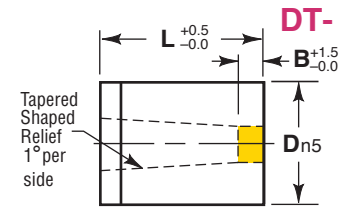

Ordering Example:

Qty Steel Type Code/B L P W Locate
5 M2 HDTS 025 x 30 P=4.00 W=4.00 LM2

Ordering Example:

Qty Steel Type Code/B L P
10 M2 DTC 050B x 40 P=20.00

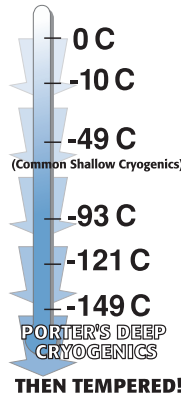
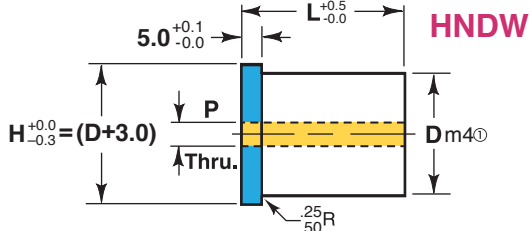

All Standard Taper Die Buttons are "Deep Cryogenically" treated for

1. Wear
2. Toughness
3. Dimensional Stability

See page 47 for details.

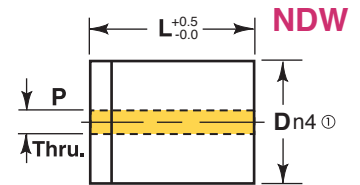

Ordering Example: Qty Type Code L
6 NDW 016 x 25

Ordering Example: Qty Type Code L
8 HNDW 025 x 32

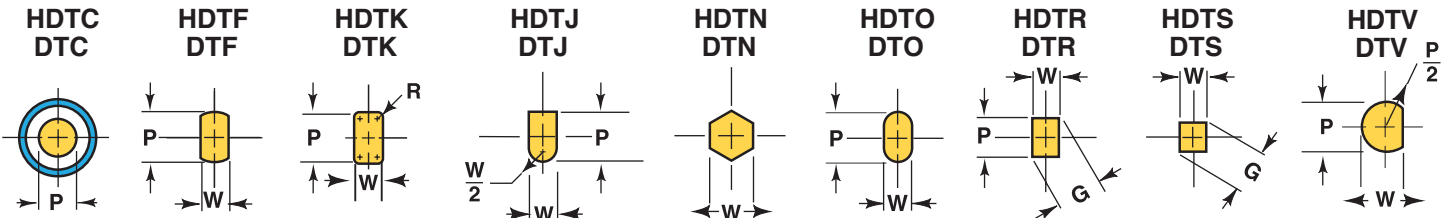

For additional standard forms and configurations see pages 36 - 39.

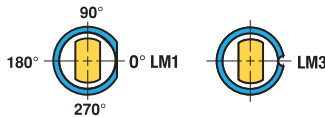

Optional Locating Methods See Page 44 & 45 for details and options.



Body D	Code No.	B			Lengths L												Range P	Min. W	Max. P/G	P Thru Hole		
		Std S	Alt A	Alt B	13	16	19	20	22	25	28	30	32	35	40	45					50	55
5	005	4	5	3	◆	◆	◆	◆	◆	◆	◆	◆	◆						1.30 - 3.20	1.30	3.20	0.8
6	006	4	5	3	◆	◆	◆	◆	◆	◆	◆	◆	◆						1.30 - 3.90	1.30	3.90	0.8
8	008	4	5	3	◆	◆	◆	◆	◆	◆	◆	◆	◆						1.30 - 5.40	1.30	5.40	0.8
10	010	4	5	3	◆	◆	◆	◆	◆	◆	◆	◆	◆						1.60 - 6.80	1.30	6.80	0.8
13	013	5	8	3	◆	◆	◆	◆	◆	◆	◆	◆	◆	●	●	●	●	●	3.00 - 8.80	1.90	8.80	1.6
16	016	5	8	3		◆	◆	◆	◆	◆	◆	◆	◆	●	●	●	●	●	7.40 - 10.80	1.90	10.80	6 & 3.0
20	020	5	10	3		◆	◆	◆	◆	◆	◆	◆	◆	●	●	●	●	●	9.50 - 13.60	1.90	13.60	6 & 3.0
22	022	6	10	3		◆	◆	◆	◆	◆	◆	◆	◆	●	●	●	●	●	10.50 - 15.00	1.90	15.00	1.6
25	025	6	10	3		◆	◆	◆	◆	◆	◆	◆	◆	●	●	●	●	●	12.00 - 17.00	1.90	17.00	6 & 3.0
32	032	6	12	3			◆	◆	◆	◆	◆	◆	◆						16.00 - 22.00	4.00	22.00	3.5
38	038	6	12	3			●	●	●	●	●	●	●						18.00 - 27.00	4.00	27.00	1.6
40	040	8	12	3			●	●	●	●	●	●	●						18.00 - 27.00	4.00	27.00	3.2
45	045	8	12	3				●	●	●	●	●	●						18.00 - 35.00	4.00	35.00	3.2
50	050	8	12	3					D	D	D	D	D						18.00 - 40.00	4.00	40.00	3.2

D=Available in DT only. ◆ Also available in PM4 Alter Taper (AT=) ● Available D2 only 58-61 Rc
*Alternate lands are available, call out "AB" and land desired (Ex "AB-5"). For perforating stock thickness less than 1 mm thick, the land should be shortened to minimize slug jamming in the die land.

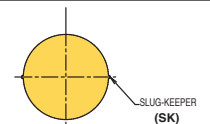

Porter's Slug keeper can be added to any round or shape die to reduce slug pulling

Standard Alterations are changes that are beyond the ranges listed in the catalog that can be altered for a minimal charge. See page 42.

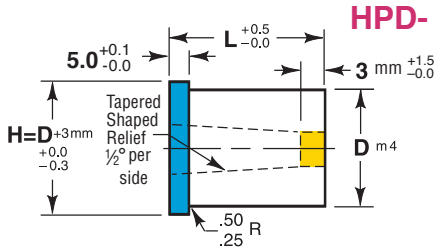

Steel: M2 Rc 60-63, PM4 Rc 63-65

TOLERANCES

$\text{Ø} \leq 38.0$ P,W $\begin{matrix} +0.005 \\ -0.000 \end{matrix}$ ◎ .008 P,W to D

$\text{Ø} > 38.0$ P,W $\begin{matrix} +0.01 \\ -0.00 \end{matrix}$ ◎ .012 P,W to D

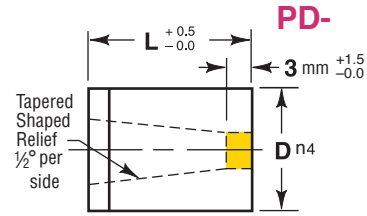

Ordering Example:

Qty Steel Type Code L P
6 M2 HPDC 016 x 25 P=9.00

Ordering Example:

Qty Steel Type Code L P W Locate
6 M2 PDO 025 x 25 P=12.00 W=6.50 LM1

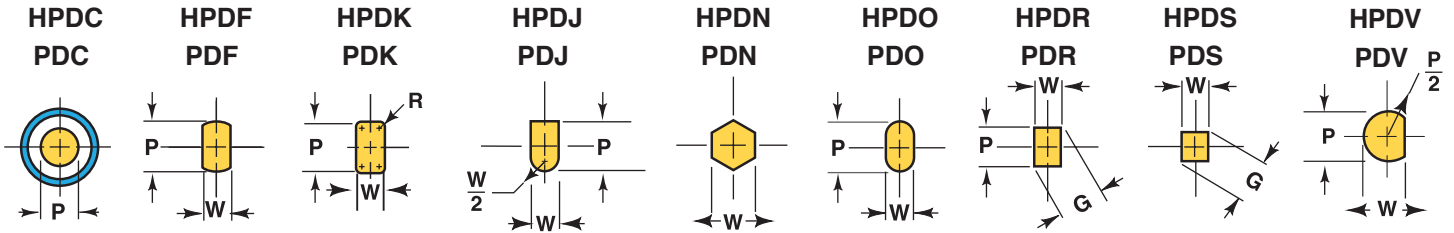

For additional standard forms and configurations see pages 36 - 39.

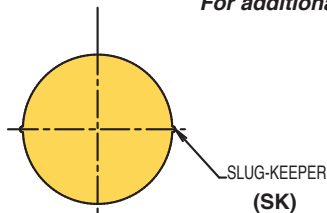
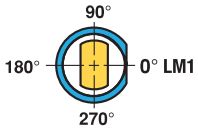

Porter's Slug keeper can be added to any round or shape die to reduce slug pulling

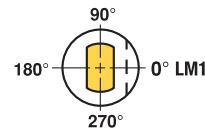

Optional Locating Methods See Page 44 & 45 for details and options.

Body D	Code No.	Lengths L									Range P	Min W	Max P/G
		13	16	19	20	22	25	28	30	32			
5	005	◆	◆	◆	◆	◆	◆	◆	◆	◆	1.60 – 3.20	1.30	3.20
6	006	◆	◆	◆	◆	◆	◆	◆	◆	◆	1.60 – 3.90	1.30	3.90
8	008	◆	◆	◆	◆	◆	◆	◆	◆	◆	2.40 – 5.40	1.30	5.40
10	010	◆	◆	◆	◆	◆	◆	◆	◆	◆	3.20 – 6.80	1.30	6.80
13	013	◆	◆	◆	◆	◆	◆	◆	◆	◆	5.40 – 8.80	1.90	8.80
16	016			◆	◆	◆	◆	◆	◆	◆	7.40 – 10.80	1.90	10.80
20	020			◆	◆	◆	◆	◆	◆	◆	9.50 – 13.60	1.90	13.60
22	022			◆	◆	◆	◆	◆	◆	◆	10.50 – 15.00	1.90	15.00
25	025			◆	◆	◆	◆	◆	◆	◆	12.00 – 17.00	1.90	17.00
32	032			◆	◆	◆	◆	◆	◆	◆	16.00 – 22.00	4.00	22.00
38	038			•	•	•	•	•	•	•	18.00 – 27.00	4.00	27.00
40	040			•	•	•	•	•	•	•	18.00 – 27.00	4.00	27.00

◆ Also available in PM4

Alter Taper (AT=)

*Standard 3mm thick land is supplied, alternate lands are available, call out "AB" and land desired (Ex "AB-5"). For perforating stock thickness less than 1 mm thick, the land should be shortened to minimize slug jamming in the die land.

Standard Alterations are changes that are beyond the ranges listed in the catalog that can be altered for a minimal charge. See page 42.

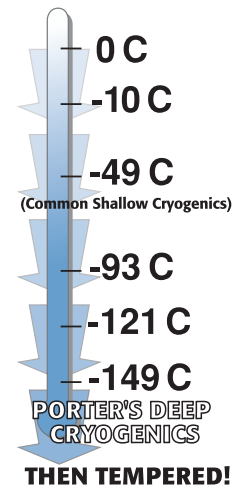

All Ultra Precision die buttons are "Deep Cryogenically" treated for
1. Wear
2. Toughness
3. Dimensional Stability

See page 47 for more details.

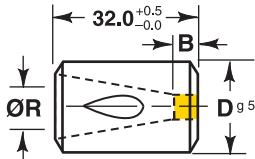

Steel: M2, Rc 60-63

TOLERANCES

Round P $\begin{matrix} +0.01 \\ -0.00 \end{matrix}$ ◎ 0.01 P to D

Shape P,W $\begin{matrix} +0.02 \\ -0.00 \end{matrix}$ ◎ 0.02 P,W to D

Ordering Example:

Qty Steel TypeCode P
25 M2 BDC 016 P=5.65

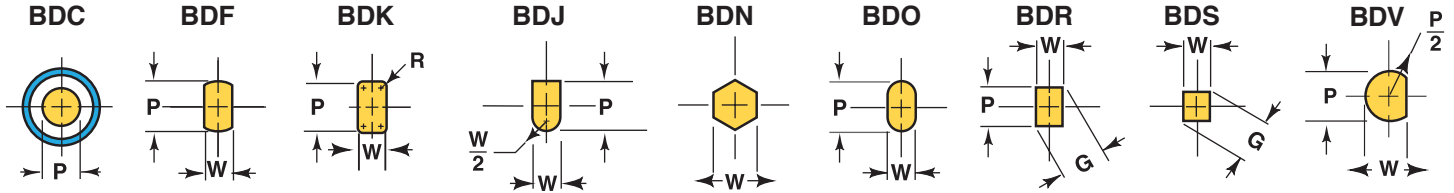

Body Code	D	Min. B	Max. R	Length L	Round I.D.		Shape I.D.	
					Range P	Min. W	Max. P/G	
13	13	4	6.00	32.0	1.50 – 5.20	1.50	5.20	
16	16	4	8.00	32.0	3.20 – 7.20	2.00	7.20	
20	20	4	12.00	32.0	4.00 – 11.00	2.40	11.00	
25	25	5	16.00	32.0	8.00 – 15.00	4.00	15.00	
32	32	6	20.00	32.0	11.00 – 19.00	4.80	19.00	
38	38	6	27.00	32.0	16.50 – 26.00	6.40	26.00	

*SPECIAL NOTE: Large quantities of Bal-Lok die buttons may be substituted with a stepped relief.

For additional standard forms and configurations see pages 36 - 39.

Standard Ball Seat location is at 90°, alternate locations of 0°, 180° and 270° are available at no extra charge. See pages 36-39 for additional standard I.D. forms.

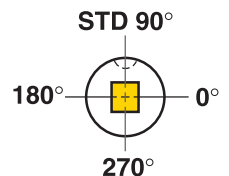

Supplied with 1% / side taper

Alter Taper (AT=)

GL-HEADLESS

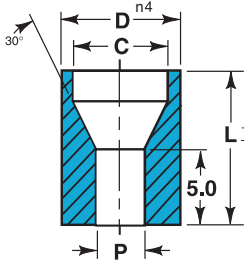

GD-HEAD-DOWN

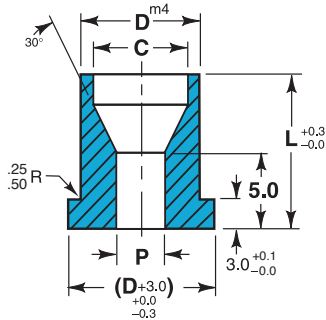

GU-HEAD-UP

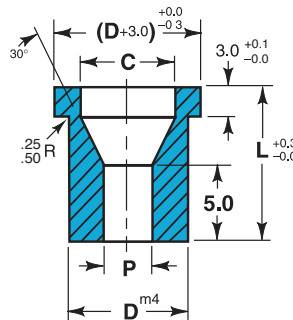

Steel: D2 Rc 58-61

TOLERANCES

P & W $\begin{matrix} +0.008 \\ -0.000 \end{matrix}$ ◎ 0.008 P to D

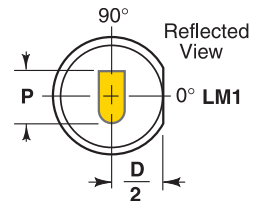

Ordering Example:

Headless 4 ea. GLC 010 x 13 P=4.50
Head-Down 4 ea. GDO 013 x 16 P= 6.00 W=2.50 LM1
Head-Up 4 ea. GUS 008 x 10 P=3.00 LM1

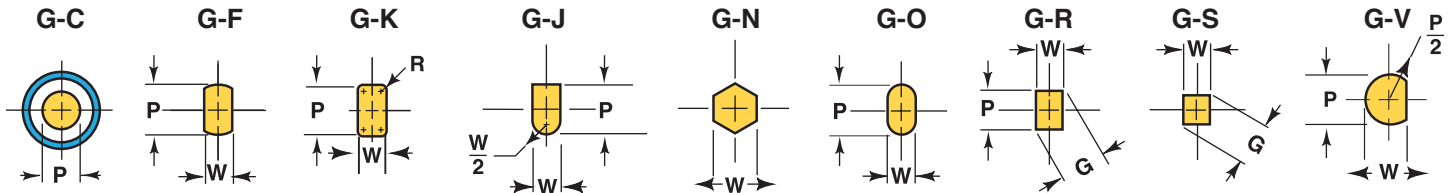

Body ØD	Code No.	Length L			Circular ID Range P	Shape ID		ØC ±0.12	Match Punch Shank Ø
		10.0	13.0	16.0		Min. W	Max. P/G		
6	006	•	•	•	1.50 – 4.00	1.50	4.00	4.37	4.0
8	008	•	•	•	1.50 – 5.00	1.50	5.00	5.37	5.0
10	010	•	•	•	1.50 – 6.00	1.50	6.00	6.37	6.0
13	013	•	•	•	2.50 – 8.00	2.00	8.00	8.37	8.0
16	016	•	•	•	3.50 – 10.00	3.20	10.00	10.37	10.0
20	020	•	•	•	5.50 – 13.00	4.50	13.00	13.37	13.0
22	022	•	•	•	8.00 – 16.00	6.00	16.00	16.37	16.0
25	025	•	•	•	10.00 – 20.00	8.00	20.00	20.37	20.0

- Locating flats and dowels, see page 44 & 45.
- Guide Bushing I.D. should be at least .0127mm larger than the punch point that it is used with.

Trumpet Head Punch (TS-)

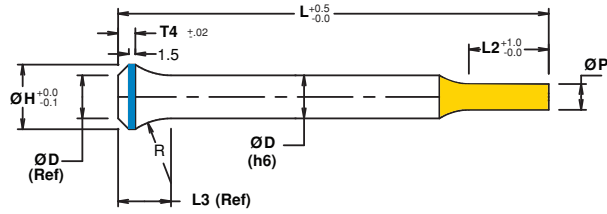

Steel: M2 Rc 60-63 PM4,
RC 63-65

TOLERANCES

Round P $+0.01$ / -0.00 Ⓞ 0.01 P to D
 Shape P, W ± 0.01 Ⓞ 0.02 P, W to D
 Back Draft 0.1/100mm L2 max.

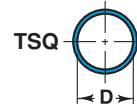

BLANKS

Ordering Example: Qty Steel Type Code L₂/L P W Locate
 25 M2 TSO 013 25/090 P=12.00 W=6.00 LM2

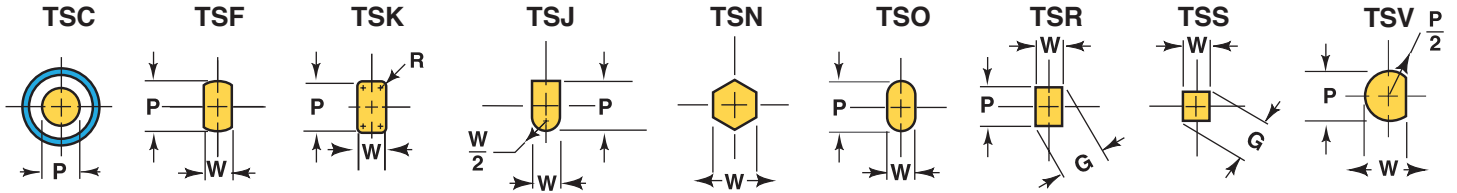

Shank		Head H	L ₃ Theoretical	L ₂ Max	R	Lengths L				Point		
D mm	Code No.					070	080	090	100	Round Range P	Shape Min W Max P/G	
4	004	5.5	7.38	25	8	•	•	•	•	1.60 – 3.99	1.60	4.00
5	005	7	8.25	25	10	•	•	•	•	1.60 – 4.99	1.60	5.00
6	006	9	9.19	25	10	•	•	•	•	1.60 – 5.99	1.60	6.00
8	008	11	9.72	25	12	•	•	•	•	2.50 – 7.99	2.50	8.00
10	010	14	11.40	25	15	•	•	•	•	3.20 – 9.99	3.20	10.00
13	013	17	11.40	25	15	•	•	•	•	5.00 – 12.99	4.50	13.00
16	016	20	11.40	25	15	•	•	•	•	8.00 – 15.99	6.00	16.00
20	020	25	12.22	25	15	•	•	•	•	10.00 – 19.99	8.00	20.00

Reflected View

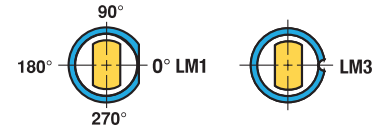

Optional Locating Methods
 See page 44 & 45
 for details and options.

Trumpet Head Ejector Punches (TR-)

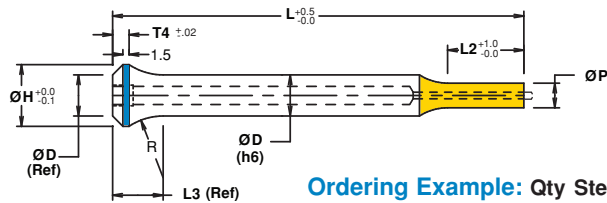

Ordering Example: Qty Steel Type Code L₂/L P
 13 M2 TRC 013 19/071 P=10.50



BLANKS

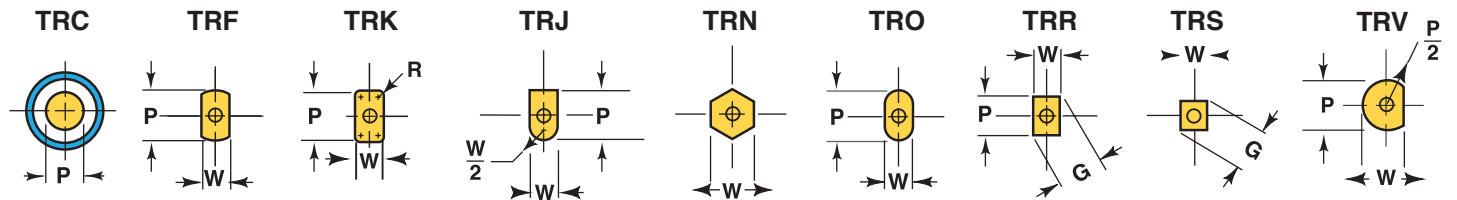

Shank		Head H	L ₃ Theoretical	L ₂ Max	Lengths L				Point			Replacement Ejector Kit*
D mm	Code No.				071	080	090	100	Round Range P	Shape Min W Max P/G		
5	005	7	8.25	25	•	•	•	•	1.60 – 4.99	1.60	5.00	K2M
6	006	9	9.19	25	•	•	•	•	2.40 – 5.99	2.40	6.00	K3M
8	008	11	9.72	25	•	•	•	•	3.20 – 7.99	3.20	8.00	K4M
10	010	14	11.40	25	•	•	•	•	4.50 – 9.99	4.50	10.00	K6M
13	013	17	11.40	25	•	•	•	•	6.00 – 12.99	6.00	13.00	K6M
16	016	20	11.40	25	•	•	•	•	8.00 – 15.99	7.20	16.00	K9M
20	020	25	12.22	25	•	•	•	•	10.00 – 19.99	8.00	20.00	K9M

* Ejector punches M2 only

For additional standard forms and configurations see pages 36 - 39.



Material:
 - Retainer:
 SAE 4140 / 43 - 48 HRC

How to Order:
 Quantity=3
 Catalog Number: THR.013

Retainer Includes:
 - 2 Screws
 - 2 Dowels

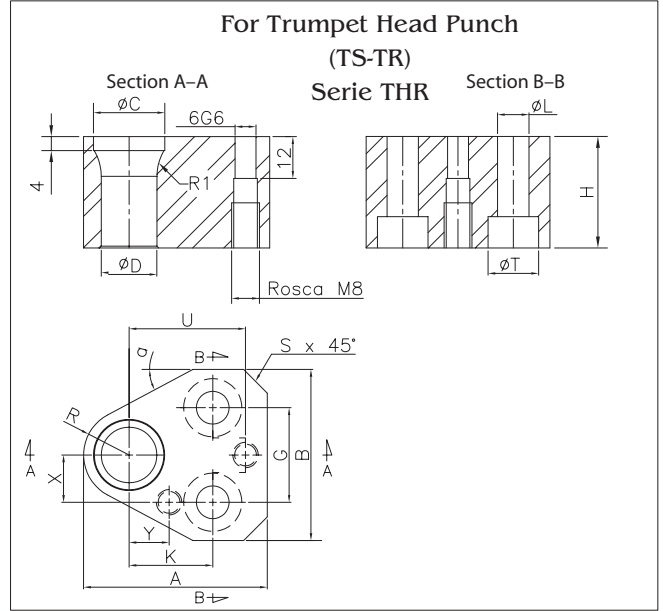

Catalog Number	ØD _{K6}	C	A	B	H	R	S	G	K	Y	U	X	L	T	R1	a°
THR006	6	9,5	35,0	37,5	25,0	8,0	5,0	22,20	19,00	9,0	23,000	8,0	7	12,0	10	30°
THR008	8	11,5	44,3	41,0	25,0	9,5	5,0	22,24	19,05	7,5	26,925	9,0	9	14,5	12	30°
THR010	10	14,5	44,3	41,0	32,0	9,5	5,0	22,24	19,05	7,5	26,925	9,0	9	14,5	15	30°
THR013	13	17,5	50,4	47,0	32,0	12,5	7,5	28,54	19,05	6,5	29,970	12,0	9	14,5	15	28°
THR016	16	20,5	53,5	50,0	32,0	14,0	8,5	31,74	19,05	6,0	31,750	13,5	9	14,5	15	28°
THR020	20	25,5	60,1	55,0	41,0	17,5	10,0	34,94	19,05	5,0	33,530	16,5	11	18,5	15	28°

Catalog Number	D
THC006	6
THC008	8
THC010	10
THC013	13
THC016	16
THC020	20



Head Type Perforators (B)

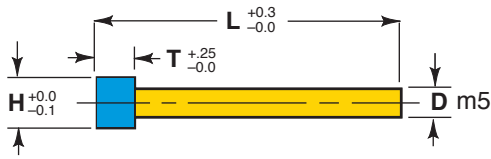

Head Type Perforators (AB)

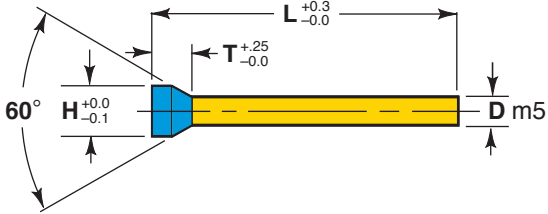

Head Type Perforators (A)

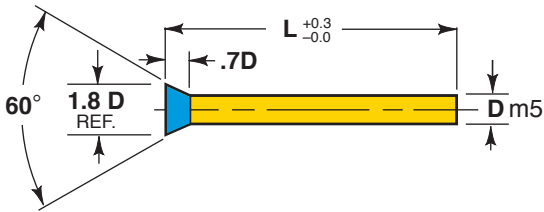

Steel: M2 Rc 60-63
Heads Rc 40-55 (L > 50)

TOLERANCES

P $\begin{matrix} +.01 \\ -.00 \end{matrix}$ © .008 P to D

D Range .8-7.0 D=m5

Ordering Example:

Qty.	Style	D	L	H	T
12	B	3.00	x 50	H=5.0	T=3.0

Pointed Perforators NB

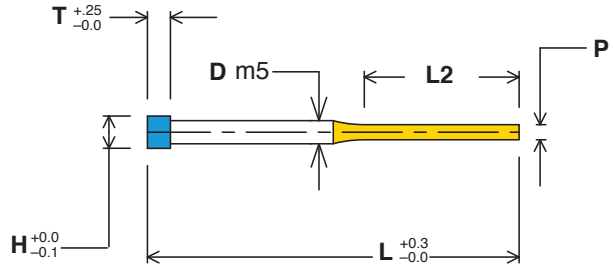

Pointed Perforators NAB

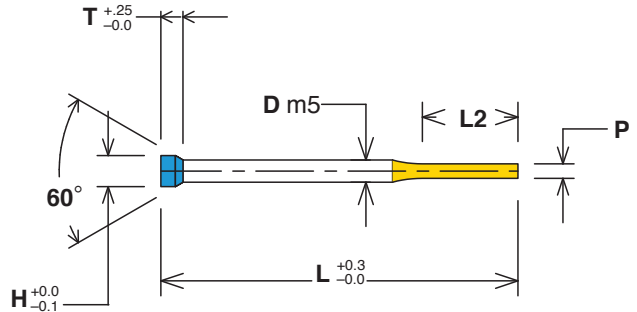

Pointed Perforators NA

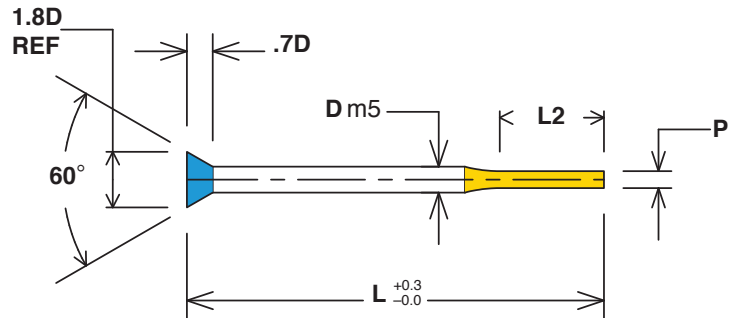

Ordering Example:

Qty.	Style	D	L	H	T	P	L ₂
12	NA	4.02	x 50			P=2.00	L ₂ =12.00
12	NB	4.02	x 50	H=5.00	T=5.00	P=2.00	L ₂ =10.00

Pilot Tips (P)

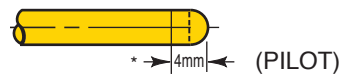

Ordering Example:

Qty.	Style	D	L	H	T	P	L ₂
6	PB	4.00	x 63	H=6.00	T=4.00		
6	PNB	4.00	x 63	H=6.00	T=4.00	P=3.00	L ₂ =13.00

*Adds 6mm max to (L) on all perforators
Angle Pilots (AP)

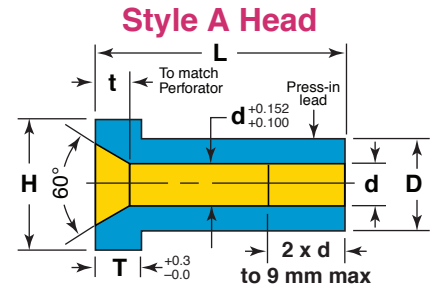
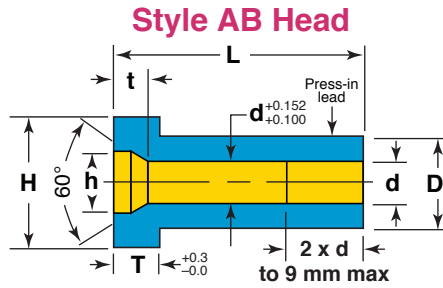
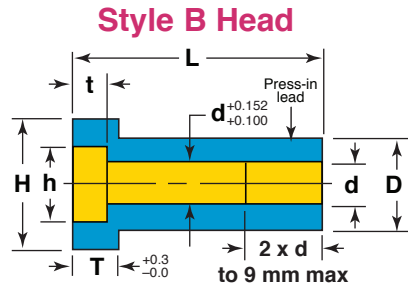

Catalog No.	D m6	m6 Chart	L						d 0.01 Increment	d Tol. F7	h	t
			20	25	32	38	45	50				
CQ-04	4	+0.012	•	•	•			1.00- 1.49	+0.021	Punch head diameter +0.35 Head thickness Diameter +.20 +.00		
CQ-06	6	+0.005	•	•	•	•		1.50- 3.00	+0.010			
CQ-08	8	+0.015	•	•	•	•		3.01- 4.29	+0.027			
CQ-10	10	+0.007	•	•	•	•	•	4.30- 6.00	+0.013			
CQ-13	13	+0.018		•	•	•	•	6.01- 8.09	+0.033			
CQ-16	16	+0.008		•	•	•	•	8.10- 9.29	+0.016			
CQ-20	20	+0.021			•	•	•	9.30-10.00	+0.040			
CQ-22	22	+0.009			•	•	•	10.01-10.49	+0.020			

Ordering Example:

Qty. Cat. No. x L x d Style
12 CQ-08 x 20 d=4.00 AB

Steel: D2, Rc 59-62
TOLERANCES
0.01 ©

Customer must supply perforator dimensions with order

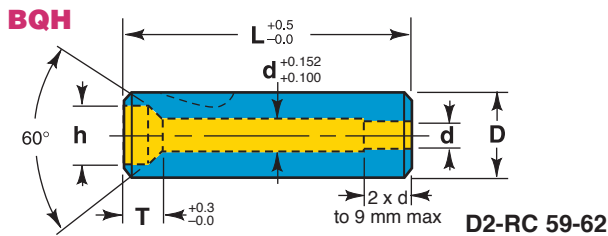

Ordering Example:

Qty. Cat. No. x L Head Style
3 BQH-013 x 32 AB

Light-Duty Ball Seat

Catalog No.	D G6	Length L	d +0.027 +0.013	h	t
BHQ-010	10	Perforator (L) - 6mm	Perforator (D) +0.027 +0.013	Perforator (H) +20 +10	Perforator (T) +2.0 -0.0
BHQ-013	13				
BHQ-016	16				
BHQ-020	20				
BHQ-025	25				
BHQ-032	32				

Customer must supply perforator dimensions with order

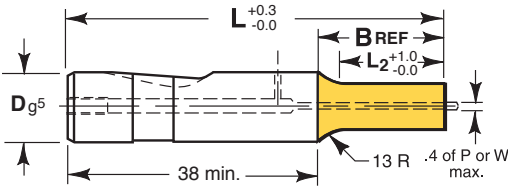

Steel: M2 Rc 60-63
PM4 Rc 63-65

TOLERANCES

Round P $\begin{matrix} +0.01 \\ -0.00 \end{matrix}$ ◎ 0.01 P to D

Shape P, W ± 0.01 ◎ 0.02 P,W to D

Back Draft 0.1/100mm L2 max.

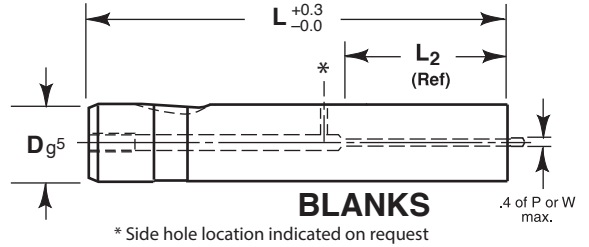

Ordering Example:

Qty Steel Type Code L₂/L P W
12 M2 HBRS 013 25/090 P=9.95 W=9.95

Ordering Example:

Qty Steel Type Code L₂/L
25 M2 HBRB 025 13/080

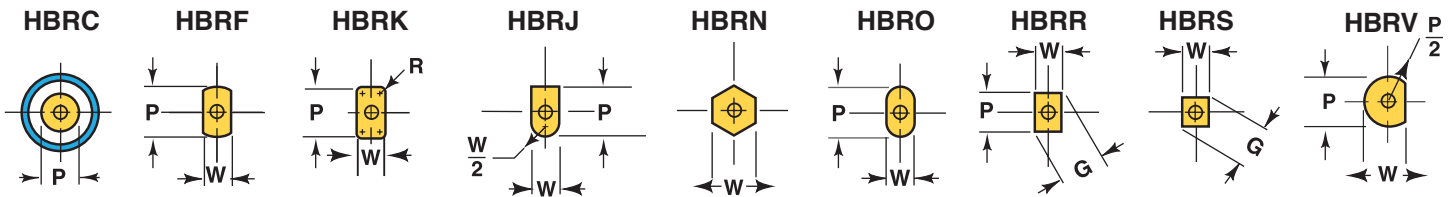
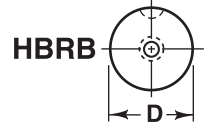

For additional standard forms and configurations see pages 36 - 39.

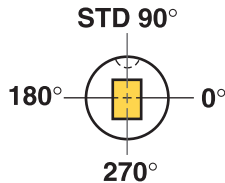

Standard ball seat location is at 90° using reflected view for punches. Alternate locations of 0°, 180° and 270° are available at no extra charge. Custom ball seat locations can be specified as number of degrees counterclockwise from 0° Example call out: BS 180°

Shank		Point Length L ₂			Lengths L								Point			Replacement Ejector Kit*
D mm	Code No.	Std.	Alt.	Alt.	063	071	080	090	100	110	125	Round		Shape		
												Range P	Min W	Max P/G		
10	010	19	10		•	•	•	•	•	•		3.00 – 9.97	3.00	9.97	K4M	
13	013	19	13	25	◆	•	•	•	•	•	•	5.00 – 12.97	4.50	12.97	K6M	
16	016	19	13	25	◆	•	•	•	•	•	•	8.00 – 15.97	6.00	15.97	K6M	
20	020	19	13	25	◆	•	•	•	•	•	•	12.00 – 19.97	8.00	19.97	K9M	
25	025	19	13	25		•	•	•	•	•	•	16.00 – 24.97	10.00	24.97	K9M	
32	032	19	13	25		•	•	•	•	•	•	24.00 – 31.97	12.50	31.97	K12M	
40	040	25	19	30			•	•	•	•	•	30.00 – 39.97	14.00	39.97	K12M	

◆ = L₂, 25 not available
◆ = Also available in PM4

32 mm Ø + larger = no side hole.

*Ejector Kits available see page 41 for details.

Standard Alterations are changes that are beyond the ranges listed in the catalog that can be altered for a minimal charge. See page 42.

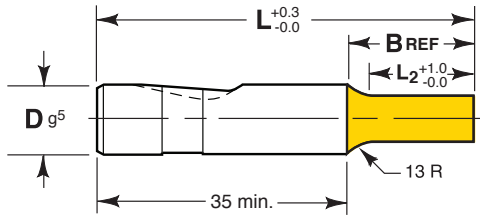

Steel: M2 Rc 60-63
PM4 Rc 63-65
TOLERANCES
Round P $\begin{matrix} +0.01 \\ -0.00 \end{matrix}$ ◎ 0.01 P to D
Shape P, W ± 0.01 ◎ 0.02 P,W to D
Back Draft 0.1/100mm L2 max.

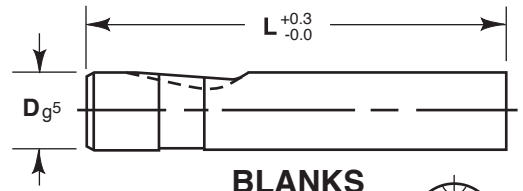

BLANKS

HBB

Ordering Example:

Qty Steel Type Code L₂/L P W
13 M2 HBO 016 19/080 P=15.00 W=7.50

Ordering Example:

Qty Steel Type Code L
6 M2 HBB 025 110

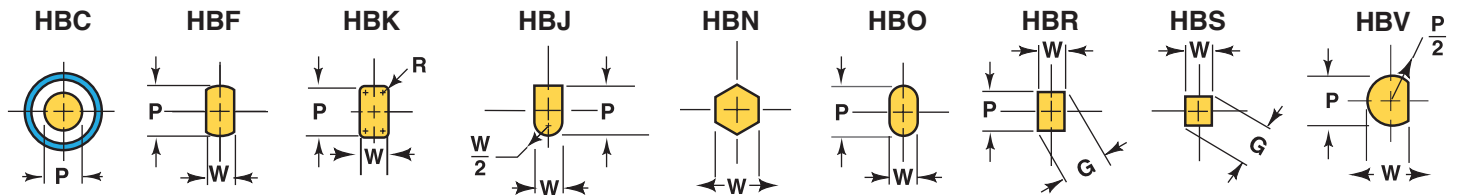

For additional standard forms and configurations see pages 36 - 39.

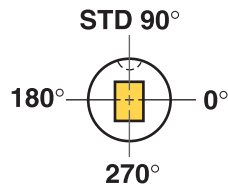

Standard ball seat location is at 90° using reflected view for punches. Alternate locations of 0°, 180° and 270° are available at no extra charge. Custom ball seat locations can be specified as number of degrees counterclockwise from 0° Example call out: BS 180°

Shank		Point Length L ₂			Lengths L								Point		
D mm	Code No.	Std.	Alt.	Alt.	063	071	080	090	100	110	125	150	Round	Shape	
													Range P	Min W	Max P/G
10	010	19	10		•	•	•	•	•	•			2.10 – 9.97	2.10	9.97
13	013	19	13	25	◆	•	•	•	•	•	•	•	5.00 – 12.97	4.50	12.97
16	016	19	13	25	◆	•	•	•	•	•	•	•	8.00 – 15.97	6.00	15.97
20	020	19	13	25	◆	•	•	•	•	•	•	•	12.00 – 19.97	8.00	19.97
25	025	19	13	25		•	•	•	•	•	•	•	16.00 – 24.97	10.00	24.97
32	032	19	13	25		•	•	•	•	•	•	•	24.00 – 31.97	12.50	31.97
40	040	25	19	30			•	•	•	•	•	•	30.00 – 39.97	14.00	39.97

◆ = L₂, 25 is not available.
◆ = Also available in PM4

Standard Alterations are changes that are beyond the ranges listed in the catalog that can be altered for a minimal charge. See page 42.

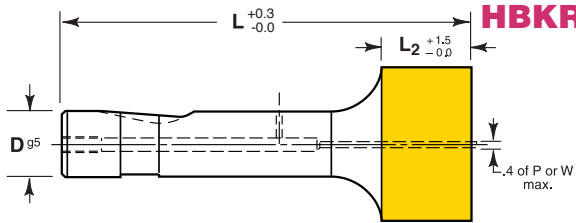

HBKR-

Steel: M2 Rc 60-63

TOLERANCES

Round P	+0.01 -0.00	◎ 0.01	P to D
Shape P, W	±0.01	◎ 0.02	P,W to D

Back Draft 0.1/100mm L2 max.

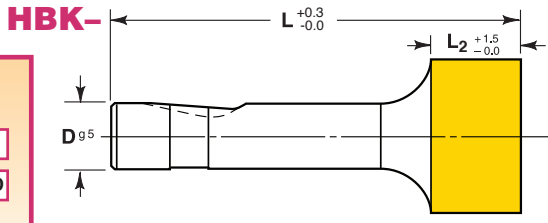

HBK-

Ordering Example:
Qty Steel Type Code L P
4 M2 HBRKC 016 090 P=32.00

Ordering Example:
Qty Steel Type Code L W P
6 M2 HBKR 032 080 W=15.00 P=30.00

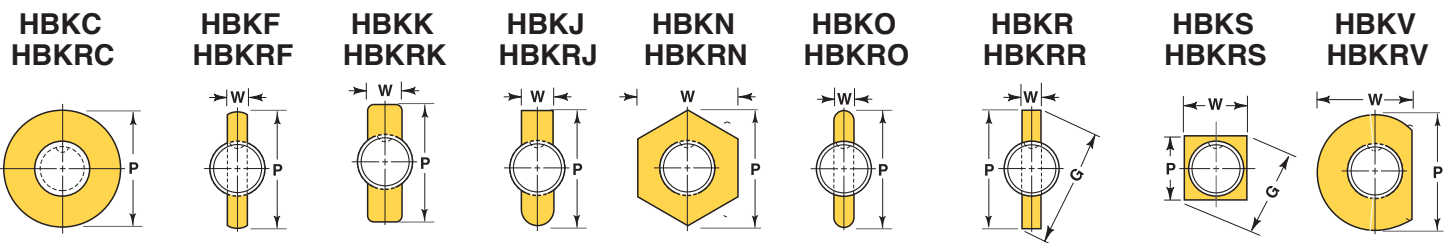

For additional standard forms and configurations see pages 36 - 39.

Shank		Point Length L ₂	Lengths L			Point			Replacement Retrako Kit*
D mm	Code No.		080	090	100	Round Range P	Shape Min W Max P/G		
13	013	20	●	●	●	13.10 – 32.00	5.00	32.00	K6M
16	016	25	●	●	●	16.10 – 38.00	6.00	38.00	K6M
20	020	25	●	●	●	20.10 – 40.00	8.00	40.00	K9M
25	025	25	●	●	●	25.10 – 44.00	10.00	44.00	K9M
32	032	32	●	●	●	32.10 – 50.00	11.50	50.00	K12M
40	040	32	●	●	●	40.10 – 56.00	14.00	56.00	K12M

*Ejector Kits available see page 41 for details.

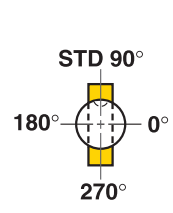

Standard ball seat location is at 90° using reflected view for punches. Alternate locations of 0°, 180° and 270° are available at no extra charge. Custom ball seat locations can be specified as number of degrees counter-clockwise from 0°.

Standard Alterations are changes that are beyond the ranges listed in the catalog that can be altered for a minimal charge. See page 42.

All shank to largest point diameter will be supplied with 13 mm metric radius blend unless otherwise specified. All inside corners will be supplied with .8 mm metric max. radius blend unless otherwise specified.



BRT 8

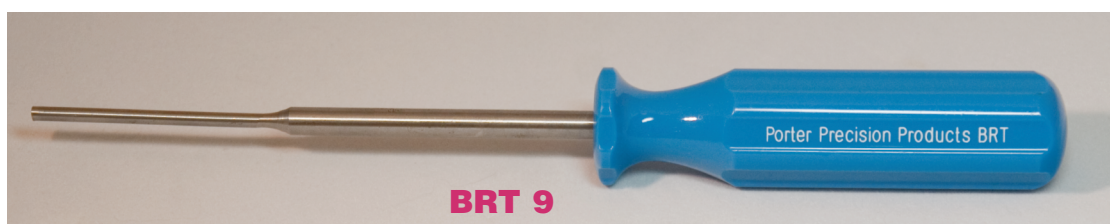

BRT 9

Regular Pilot-HBP Type

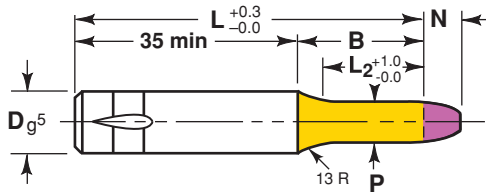

Steel: M2 Rc 60-63
PM4 Rc 63-65

TOLERANCES

P $\begin{matrix} +0.01 \\ -0.00 \end{matrix}$ © 0.01 P to D

B & L Lengths do not include Pilot Tip N

Ordering Example:

Qty Steel Type Code L₂/L P
15 M2 HBP 016 15/082 P=9.25

Shank D	Pilot Type	Lengths L ₂			Lengths L						N MAX	Round Range P	
		Std.	Alt.	Alt.	065	073	082	092	102	112			127
10	HBP010	21	12		●	●	●	●	●	●		4.0	2.05 – 9.97
13	HBP013	21	15	27	◆	●	●	●	●	●	●	4.0	4.95 – 12.97
16	HBP016	21	15	27	◆	●	●	●	●	●	●	4.0	7.95 – 15.97
20	HBP020	21	15	27	◆	●	●	●	●	●	●	4.0	11.95 – 19.97
25	HBP025	21	15	27	◆	●	●	●	●	●	●	4.0	15.95 – 24.97
32	HBP032	21	15	27	◆	●	●	●	●	●	●	4.0	23.95 – 31.97
40	HBP040	27	21	32		●	●	●	●	●		4.0	29.95 – 39.97

◆ = L₂, 27 not available

◆ ● Also available in PM4

Angular Pilot-HBAP Type

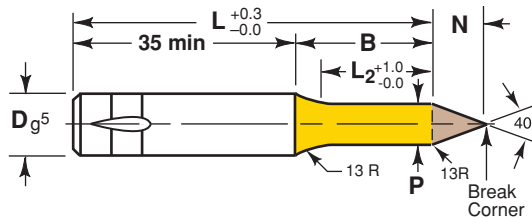

B & L Lengths do not include Pilot Tip N

Ordering Example:

Qty Steel Type Code L₂/L P
19 M2 HBAP 010 19/080 P=7.77

Shank D	Pilot Type	Lengths L ₂		Lengths L					N MAX	Round Range P
		Std.	Alt.	080	090	100	110	125		
10	HBAP010	19	32	●	●	●	●		8	5.00 – 9.97
13	HBAP013	19	32	●	●	●	●		10	9.00 – 12.97
16	HBAP016	25	38	●	●	●	●		15	12.00 – 15.97
20	HBAP020	25	38	●	●	●	●		20	15.00 – 19.97
25	HBAP025	25	38	●	●	●	●		25	19.00 – 24.97
32	HBAP032	25	38	●	●	●	●		30	24.00 – 31.97

● Also available in PM4

Standard Alterations are changes that are beyond the ranges listed in the catalog that can be altered for a minimal charge. See page 42.

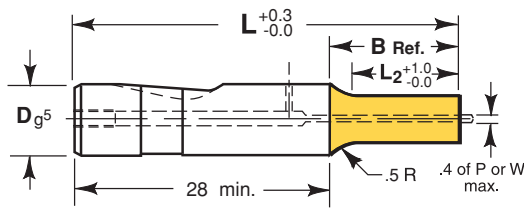

Steel: M2 Rc 60-63

TOLERANCES

Round P $\begin{matrix} +0.01 \\ -0.00 \end{matrix}$ ⊙ 0.01 P to D

Shape P, W ± 0.01 ⊙ 0.02 P,W to D

Back Draft 0.1/100mm L2 max.

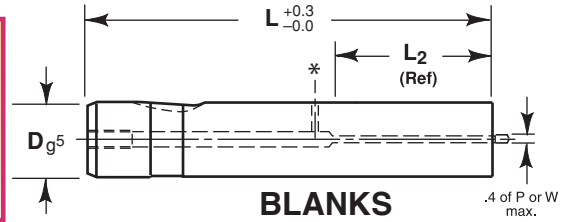

BLANKS

* Side hole location indicated on request

Ordering Example:

Qty Steel Type Code L₂/L P W
10 M2 BRR 010 19/071 P=5.50 P=3.00

Ordering Example:

Qty Steel Type Code L
15 M2 BRB 025 13/080

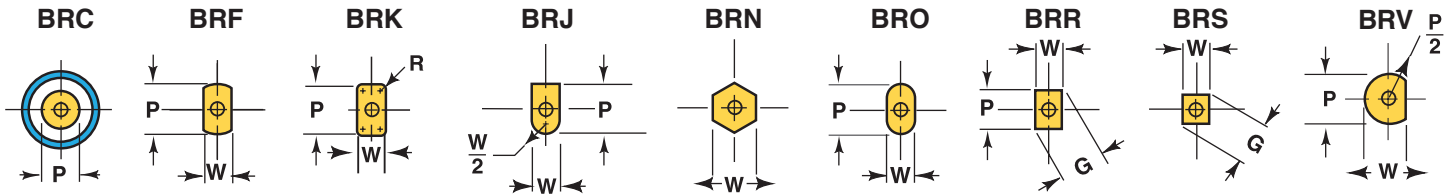
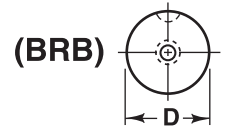

For additional standard forms and configurations see pages 36 - 39.

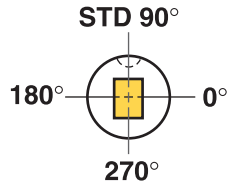

Standard ball seat location is at 90° using reflected view for punches. Alternate locations of 0°, 180° and 270° are available at no extra charge. Custom ball seat locations can be specified as number of degrees counterclockwise from 0° Example call out: BS 180°

Shank		Point Length L ₂			Lengths L					Point		Replacement Ejector Kit*	
D mm	Code No.	Std.	Alt.	Alt.	063	071	080	090	100	Round			
										Range P	Min W		Max P/G
6	006	13	10		•	•	•	•	•	2.10 – 5.97	2.10	5.97	K3M
10	010	19	10		•	•	•	•	•	2.10 – 9.97	2.10	9.97	K3M
13	013	19	13		•	•	•	•	•	5.00 – 12.97	4.50	12.97	K6M
16	016	19	13	25	•	•	•	•	•	8.00 – 15.97	6.00	15.97	K6M
20	020	19	13	25	•	•	•	•	•	12.00 – 19.97	8.00	19.97	K9M
25	025	19	13	25	•	•	•	•	•	16.00 – 24.97	10.00	24.97	K9M
32	032	19	13	25		•	•	•	•	24.00 – 31.97	12.50	31.97	K12M

*Ejector kits available see page 41 for details.

32 mm Ø = no side hole

Standard Alterations are changes that are beyond the ranges listed in the catalog that can be altered for a minimal charge. See page 42.

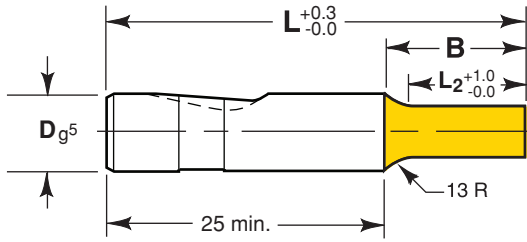

Steel: M2 Rc 60-63

TOLERANCES

Round P $\begin{matrix} +0.01 \\ -0.00 \end{matrix}$ $\text{◎} 0.01$ P to D

Shape P, W ± 0.01 $\text{◎} 0.02$ P,W to D

Back Draft 0.1/100mm L2 max.

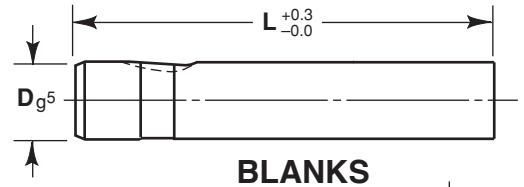

BLANKS

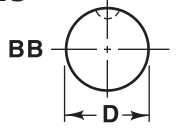

Ordering Example:

Qty	Steel	Type	Code	L ₂ /L	P	W
15	M2	BS	025	25/080	P=13.00	P=13.00

Ordering Example:

Qty	Steel	Type	Code	L
25	M2	BB	016	080

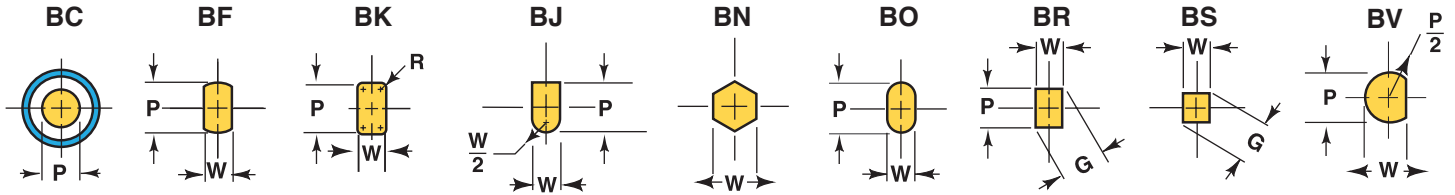

For additional standard forms and configurations see pages 36 - 39.

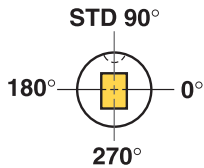

Standard ball seat location is at 90° using reflected view for punches. Alternate locations of 0°, 180° and 270° are available at no extra charge. Custom ball seat locations can be specified as number of degrees counterclockwise from 0° Example call out: BS 180°

Shank		Point Length			Lengths								Point		
D mm	Code No.	L ₂			L								Round	Shape	
		Std.	Alt.	Alt.	063	071	080	090	100	107	118	131	Range P	Min W	Max P/G
6	006	13	10		•	•	•	•	•				2.10 – 5.97	2.10	5.97
10	010	19	10		•	•	•	•	•				2.10 – 9.97	2.10	9.97
13	013	19	13	25	•	•	•	•	•	•	•	•	5.00 – 12.97	4.50	12.97
16	016	19	13	25	•	•	•	•	•	•	•	•	8.00 – 15.97	6.00	15.97
20	020	19	13	25	•	•	•	•	•	•	•	•	12.00 – 19.97	8.00	19.97
25	025	19	13	25	•	•	•	•	•	•	•	•	16.00 – 24.97	10.00	24.97
32	032	19	13	25		•	•	•	•	•	•	•	24.00 – 31.97	12.50	31.97

Standard Alterations are changes that are beyond the ranges listed in the catalog that can be altered for a minimal charge. See page 42.

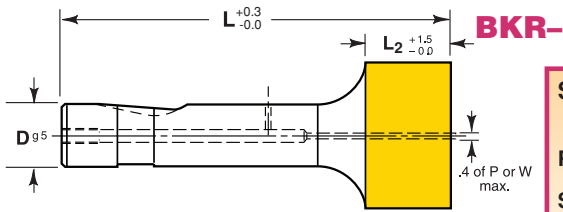

Steel: M2 Rc 60-63
TOLERANCES
 Round P $+0.01$ -0.00 ◎ 0.01 P to D
 Shape P, W ± 0.01 ◎ 0.02 P,W to D
 Back Draft 0.1/100mm L2 max.

Ordering Example:

Qty Steel Type Code L P
 15 M2 BRKC 013 080 P=25.20

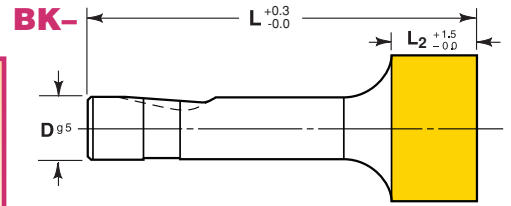

Ordering Example:

Qty Steel Type Code L P W
 4 M2 BKS 020 100 P=23.00 P=23.00

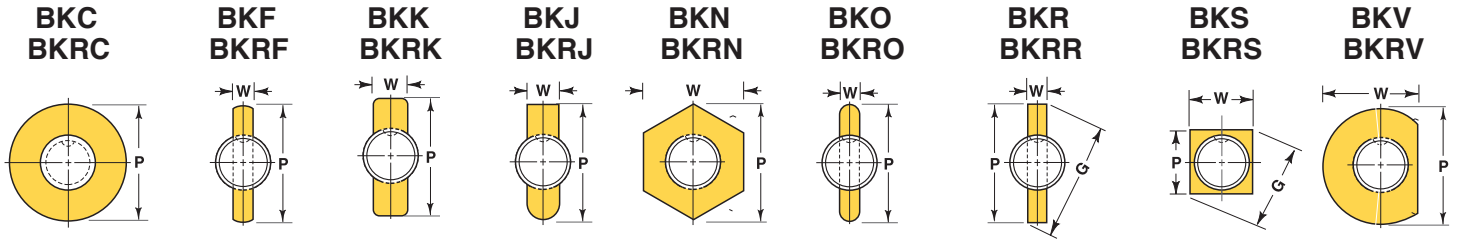

For additional standard forms and configurations see pages 36 - 39.

Shank		Point Length L ₂	Lengths L			Point			Replacement Ejector Kit*
D mm	Code No.		080	090	100	Round Range P	Shape Min W Max P/G		
13	013	20	●	●	●	13.10 – 32.00	5.00	32.00	K6M
16	016	25	●	●	●	16.10 – 38.00	6.00	38.00	K6M
20	020	25	●	●	●	20.10 – 40.00	8.00	40.00	K9M
25	025	25	●	●	●	25.10 – 44.00	10.00	44.00	K9M
32	032	32	●	●	●	32.10 – 50.00	11.50	50.00	K12M

*Ejector Kits available see page 41 for details.

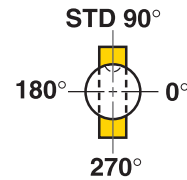

Standard ball seat location is at 90° using reflected view for punches. Alternate locations of 0°, 180° and 270° are available at no extra charge. Custom ball seat locations can be specified as number of degrees counterclockwise from 0°.

Standard Alterations are changes that are beyond the ranges listed in the catalog that can be altered for a minimal charge. See page 42.

Regular Parabolic Pilot-BP

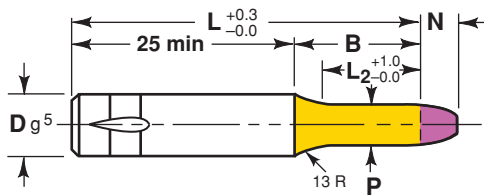

Steel: M2 Rc 60-63

TOLERANCES

P $\begin{matrix} +0.01 \\ -0.00 \end{matrix}$

⊙

0.01

P to D

B & L Lengths do not include Pilot Tip N

Ordering Example:

Qty Steel Type Code L₂/L P
7 M2 BP 020 27/092 P=15.00

Shank		Lengths L ₂			Lengths L							N	Round
D	Pilot Type	Std.	Alt.	Alt.	065	073	082	092	102	112	127	MAX	Range P
6	BP006	15	12		•	•	•	•	•			4.0	2.05 – 5.97
10	BP010	21	12		•	•	•	•	•	•		4.0	2.05 – 9.97
13	BP013	21	15	27	•	•	•	•	•	•	•	4.0	4.95 – 12.97
16	BP016	21	15	27		•	•	•	•	•	•	4.0	7.95 – 15.97
20	BP020	21	15	27		•	•	•	•	•	•	4.0	11.95 – 19.97
25	BP025	21	15	27		•	•	•	•	•	•	4.0	15.95 – 24.97
32	BP032	21	15	27				•	•	•	•	4.0	23.95 – 31.97

Angular Pilot-BAP Type

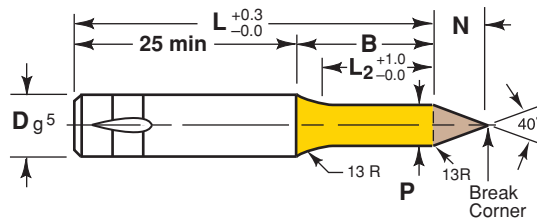

B & L Lengths do not include Pilot Tip N

Ordering Example:

Qty Steel Type Code L₂/L P
19 M2 BAP 010 19/080 P=7.77

Shank		Lengths L ₂		Lengths L					N	Round
D	Pilot Type	Std.	Alt.	071	080	090	100	110	MAX	Range P
10	BAP010	19	32	•	•	•	•	•	8.0	5.00 – 9.97
13	BAP013	19	32	•	•	•	•	•	10.0	9.00 – 12.97
16	BAP016	25	38	•	•	•	•	•	15.0	12.00 – 15.97
20	BAP020	25	38	•	•	•	•	•	20.0	15.00 – 19.97
25	BAP025	25	38	•	•	•	•	•	25.0	19.00 – 24.97
32	BAP032	25	38		•	•	•		30.0	24.00 – 31.97

Standard Alterations are changes that are beyond the ranges listed in the catalog that can be altered for a minimal charge. See page 42.



Retainer Set Includes:

- 2 Screws
- 2 Dowels

Material:
Retainer: SAE 4140/43-48 HRC.

Catalog #:
MRR xxx

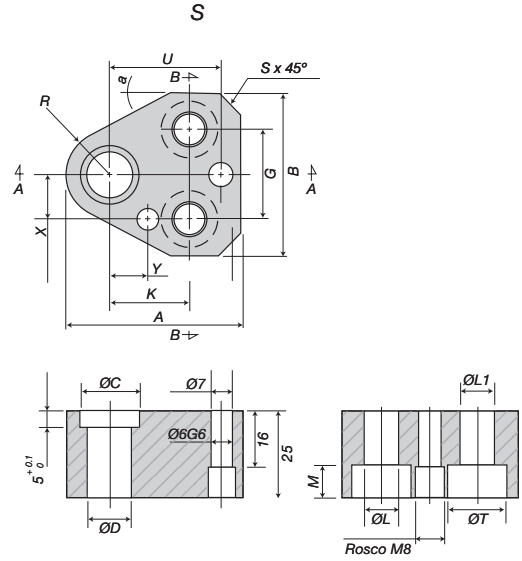

METRIC

Catalog #	ØD	C	A	B	R	S	G	K	Y	U	X	L=L1	T	M	a°
MRR008	8	12.0	44.5	41	9.5	5.0	22.24	19.05	7.5	26.925	9.0	9	14.5	9	30°
MRR010	10	14.5	44.5	41	9.5	5.0	22.24	19.05	7.5	26.925	9.0	9	14.5	9	30°
MRR013	13	18.0	50.5	47	12.5	6.5	28.54	19.05	6.5	29.970	12.0	9	14.5	9	28°
MRR016	16	20.5	53.5	50	14.0	7.0	31.74	19.05	6.0	31.750	13.5	9	14.5	9	28°
MRR020	20	25.5	60.0	55	17.5	8.0	34.94	19.05	5.0	33.530	16.5	11	18.0	11	28°
MRR025	25	30.5	69.5	63	22.0	9.0	39.68	23.82	7.0	40.640	22.0	14	20.5	13	28°
MRR032	32	38.5	69.5	63	22.0	9.0	39.68	23.82	7.0	40.640	22.0	14	20.5	13	28°



Retainer Set Includes:

- 2 Screws
- 2 Dowels

Material:
Retainer: SAE 4140/43-48 HRC.

Catalog #:
MSR xxx

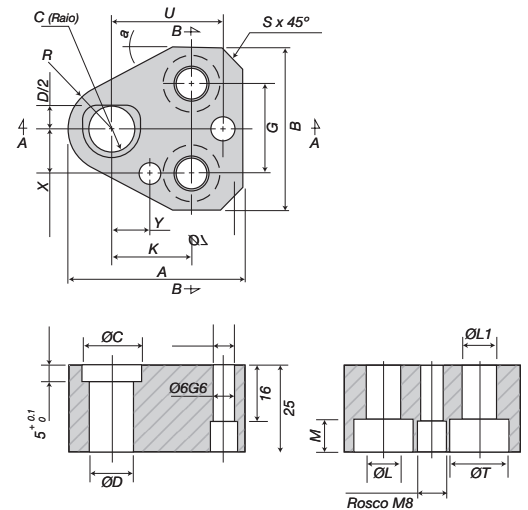

METRIC

Catalog #	ØD	C	A	B	R	S	G	K	Y	U	X	L=L1	T	M	a°
MSR008	8	6.0	44.5	41	9.5	5.0	22.24	19.05	7.5	26.925	9.0	9	14.5	9	30°
MSR010	10	7.3	44.5	41	9.5	5.0	22.24	19.05	7.5	26.925	9.0	9	14.5	9	30°
MSR013	13	9.0	50.5	47	12.5	6.5	28.54	19.05	6.5	29.970	12.0	9	14.5	9	28°
MSR016	16	10.3	53.5	50	14.0	7.0	31.74	19.05	6.0	31.750	13.5	9	14.5	9	28°
MSR020	20	12.8	60.0	55	17.5	8.0	34.94	19.05	5.0	33.530	16.5	11	18.0	11	28°
MSR025	25	15.3	69.5	63	22.0	9.0	39.68	23.82	7.0	40.640	22.0	14	20.5	13	28°
MSR032	32	19.3	69.5	63	22.0	9.0	39.68	23.82	7.0	40.640	22.0	14	20.5	13	28°

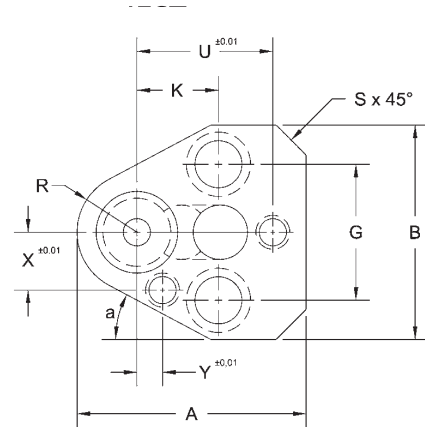

Retainer Set Includes:

- 1 Ball
- 2 Dowels
- 1 Spring
- 1 Ball Release
- 2 Screws
- SHCS

Material:

Retainer: SAE 4140/43-48 HRC.
Backing Plug: SAE S1 / 50 - 54 HRC.

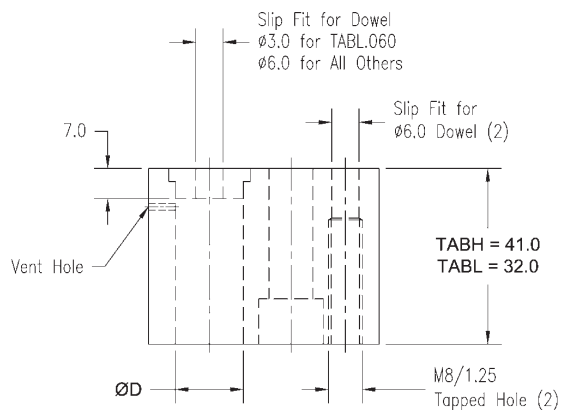

METRIC

Catalog Number	ØD	A	B	U	Y	K	G	X	R	S	a°	Screw Size
LIGHT DUTY												
MLR 006	6	35.0	37.5	23.000	9.0	19.0	22.00	8.0	8.0	5.0	30°	M6/1.00
MLR 010	10	44.3	41	26.925	7.5	19.05	22.24	9.0	9.5	5.0	30°	M8/1.25
MLR 013	13	50.4	47	29.970	6.5	19.05	28.54	12.0	12.5	6.0	28°	M8/1.25
MLR 016	16	53.5	50	31.750	6.0	19.05	31.74	13.5	14.0	7.0	28°	M8/1.25
MLR 020	20	60.1	55	33.530	5.0	19.05	34.94	16.5	17.5	8.0	28°	M10/1.50
MLR 025	25	69.7	63	40.640	7.0	23.82	39.68	22.0	22.0	9.0	28°	M12/1.75
MLR 032	32	69.7	63	40.640	7.0	23.82	39.68	22.0	22.0	9.0	28°	M12/1.75
HEAVY DUTY												
MHR 010	10	44.3	41	26.925	7.5	19.05	22.24	9.0	9.5	5.0	30°	M8/1.25
MHR 013	13	50.4	47	29.970	6.5	19.05	28.54	12.0	12.5	6.5	28°	M8/1.25
MHR 016	16	53.5	50	31.750	6.0	19.05	31.74	13.5	14.0	7.0	28°	M8/1.25
MHR 020	20	60.1	55	33.530	5.0	19.05	34.94	16.5	17.5	8.0	28°	M10/1.50
MHR 025	25	69.7	63	40.640	7.0	23.82	39.68	22.0	22.0	9.0	28°	M12/1.75
MHR 032	32	69.7	63	40.640	7.0	23.82	39.68	22.0	22.0	9.0	28°	M12/1.75
MHR 040	40	76.4	73	43.993	10.0	27.00	48.00	26.0	26.0	10.0	28°	M12/1.75

Forms

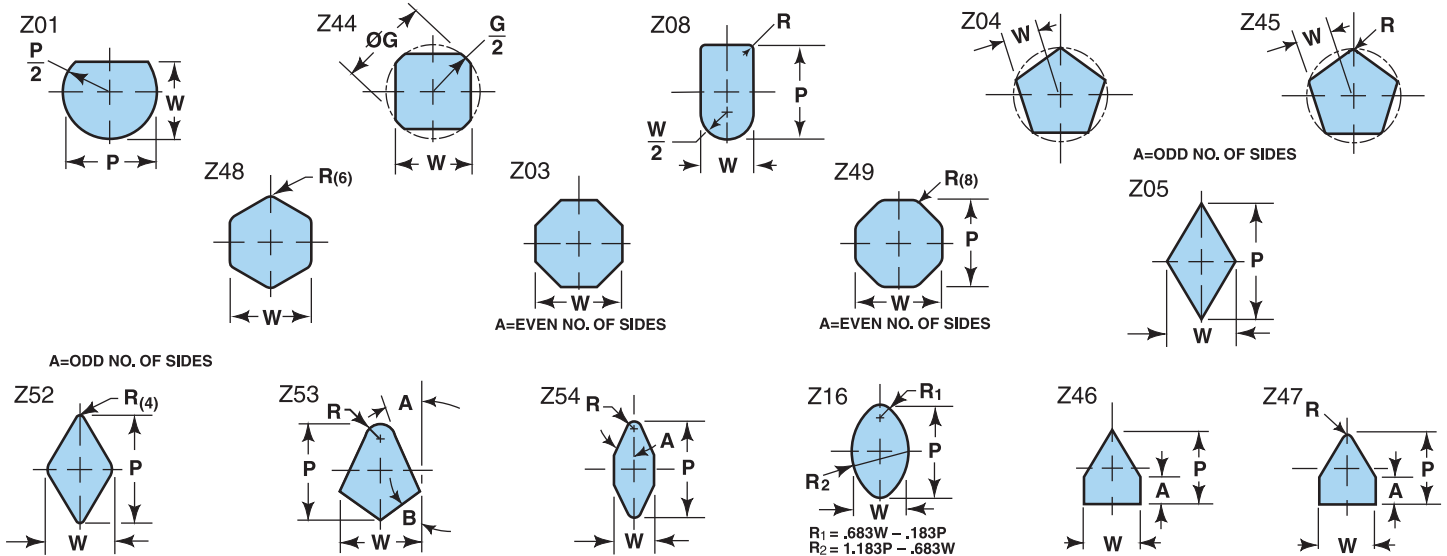

Triangles & Trapezoid Forms

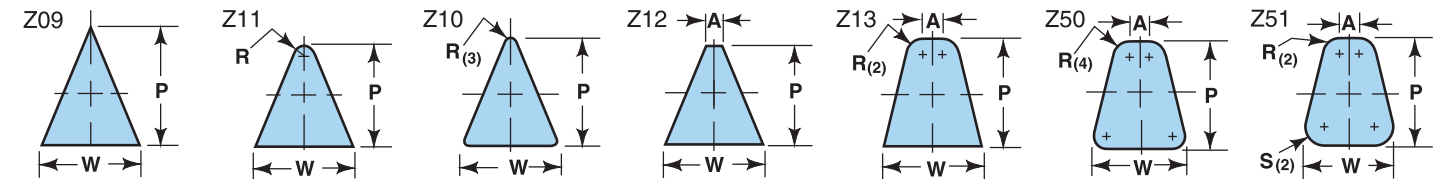

Keyhole & Teardrop Forms

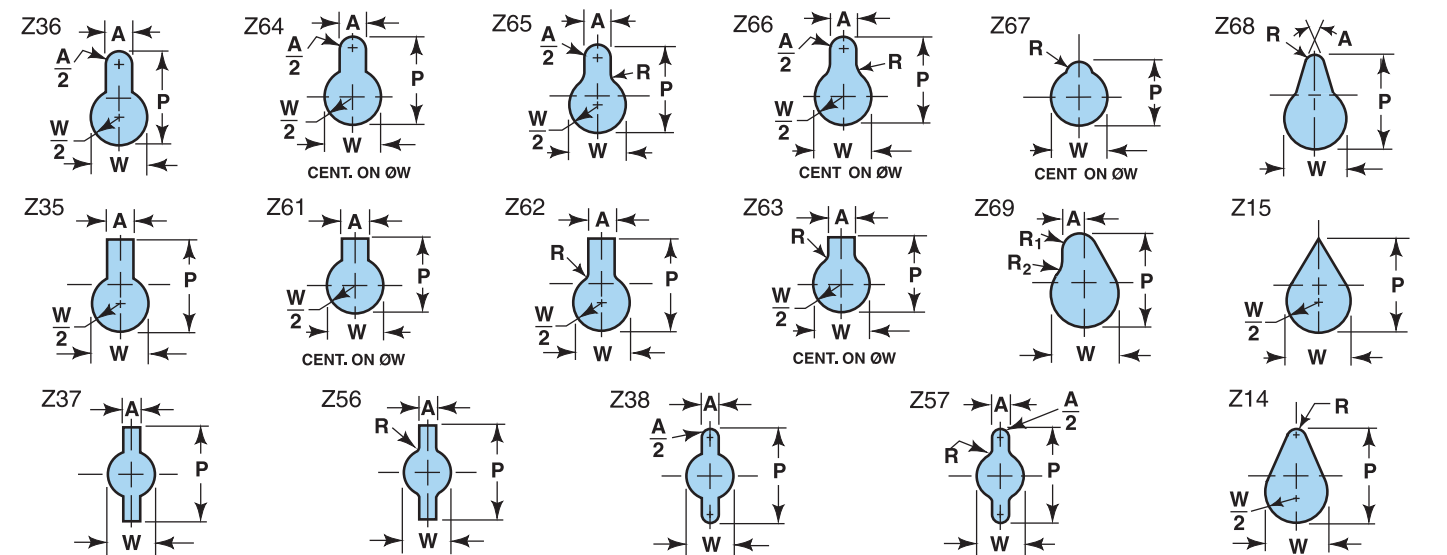

Knock-Out Forms

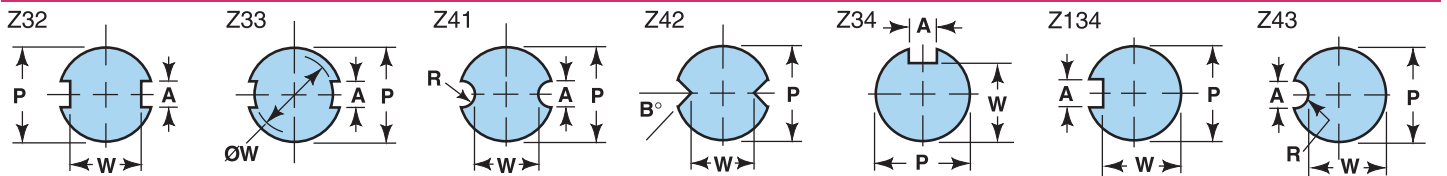

In cases where clearance per side (Ø) is $.08 \text{ Ø}$ or less we will break the sharp corners to eliminate interference, when punches, and/or guides and dies are ordered together.

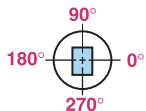

VIEWS: Shown as in-die position. This is reflected view for punch and guide, plan view (thru cutting end) of die button. See page 39 for details.

CENTERING: Forms are centered to the shank or body as shown. Exception being forms Z09 and Z15, will not be centered on P due to clearance.

When Ordering Forms Specify: Qty Mat. Type Code L₂/L Form P W R Locate
 5 M2 () Z 010 19/080 Z-06 P=6.0 W=4.0 1.0 LM1

U Shape Forms

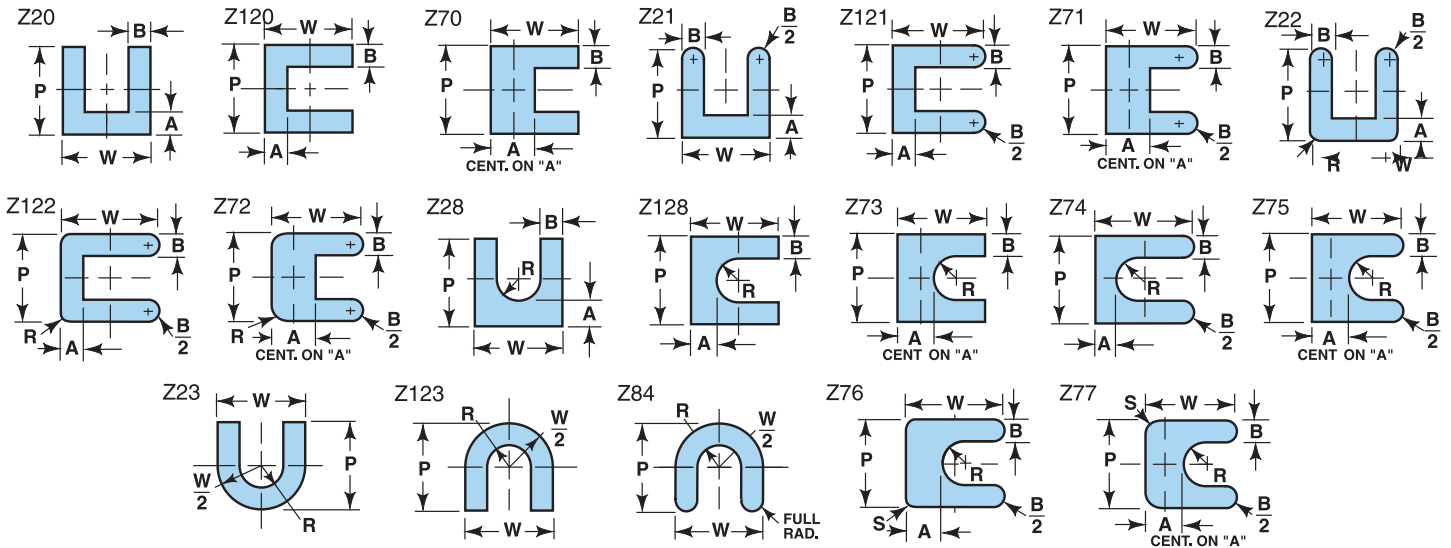

L Shape Forms

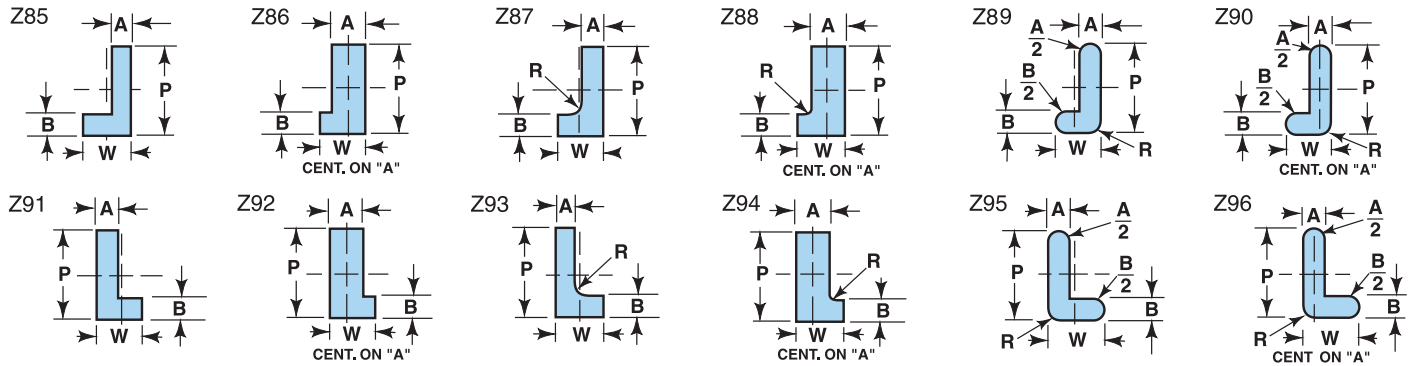

Spline Shape Forms

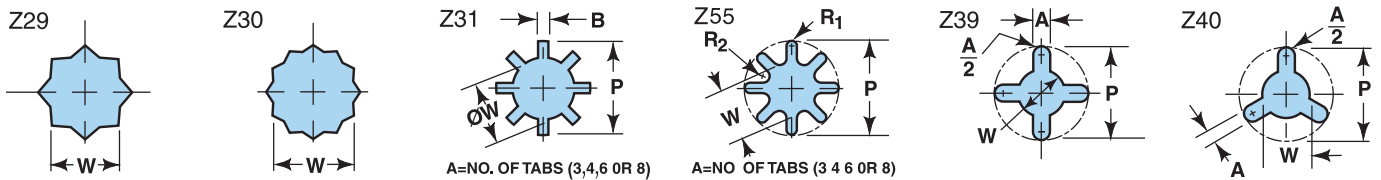

Knock-Out Forms

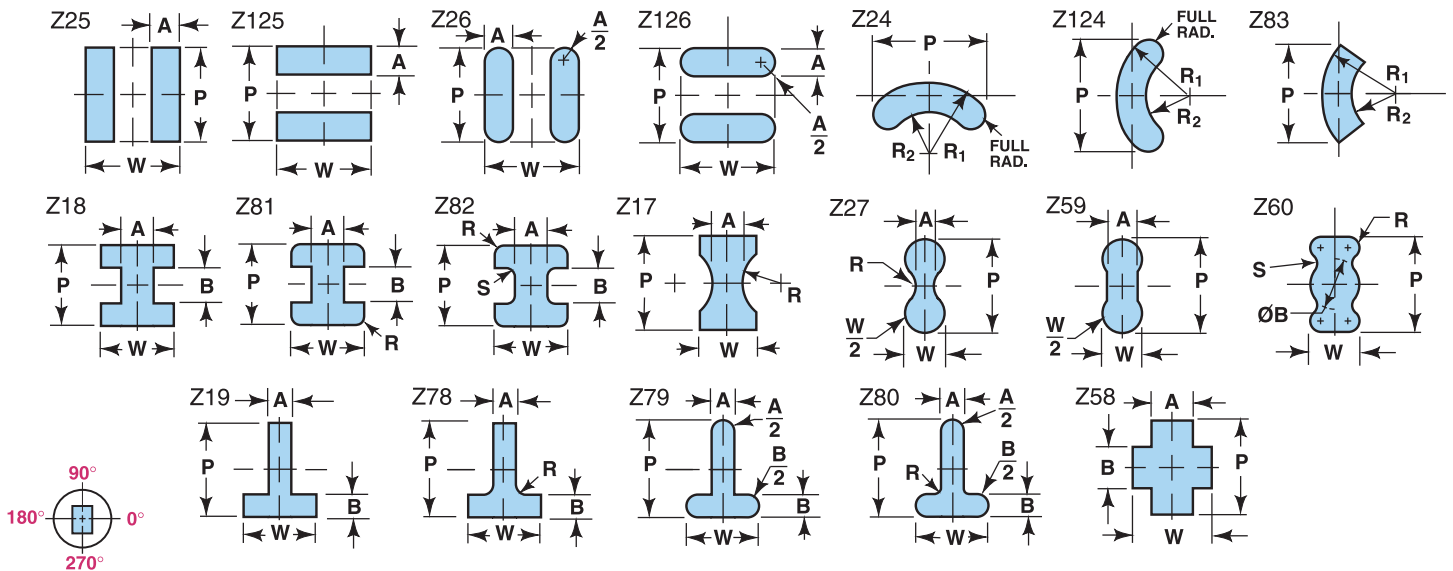

ORIENTATION: Bal-Lok Punch and Die Button Standard Ballseat location is at 90°. For all else standard flat and dowel location is at 0°. Alternate and custom locations are also available, see orientation guidelines.

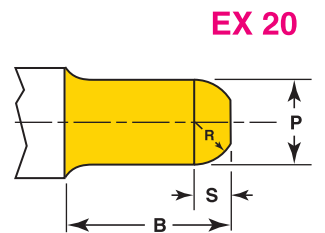
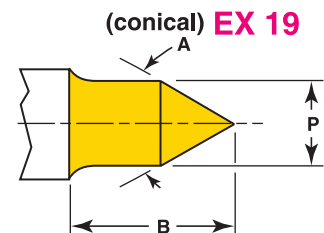
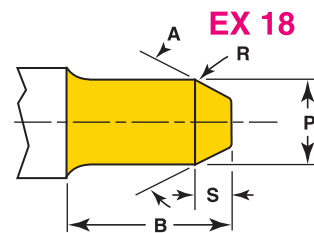
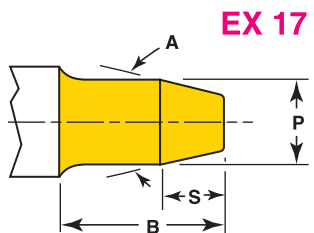
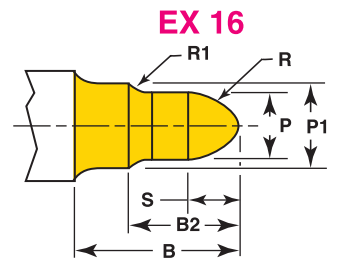
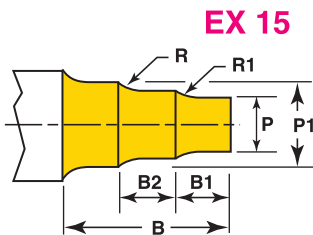
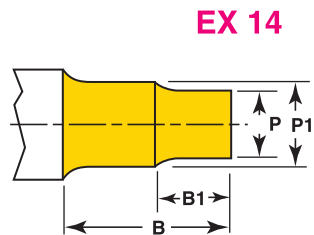
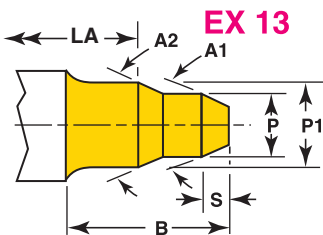
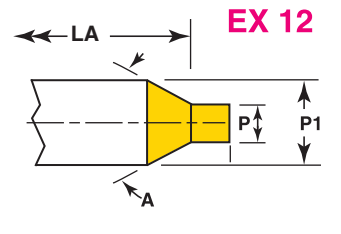
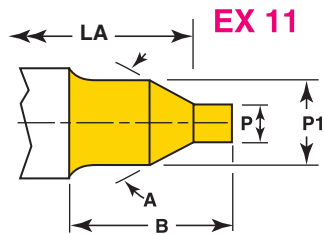
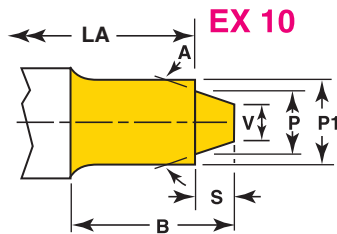
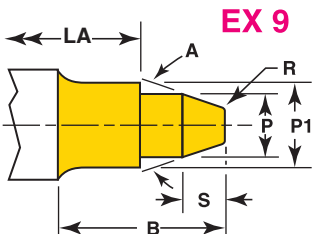
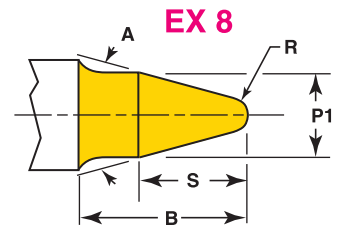
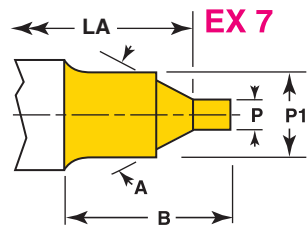
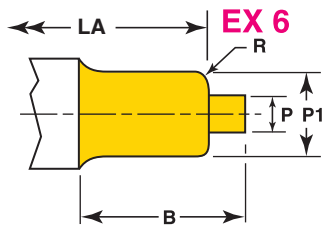
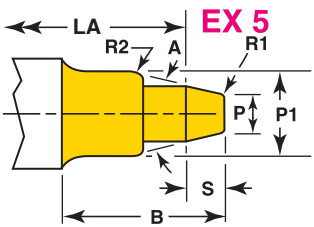
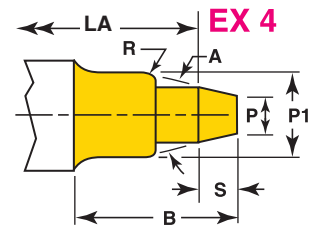
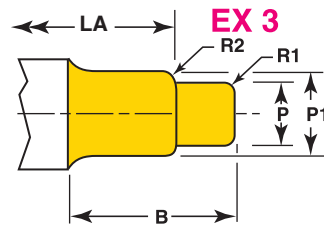
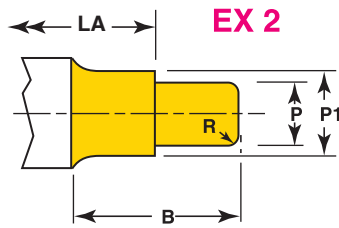
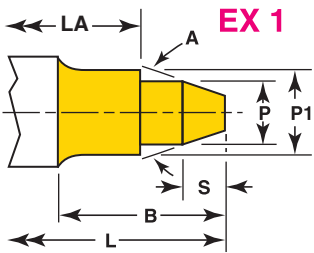
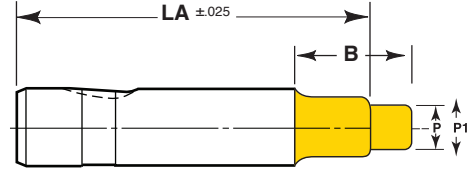
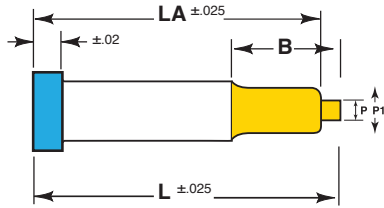

All shank to largest point diameter will be supplied with 13mm radius blend unless otherwise specified. All inside corners will be supplied with .5mm radius blend unless otherwise specified.

For LA information see panel on page 39.

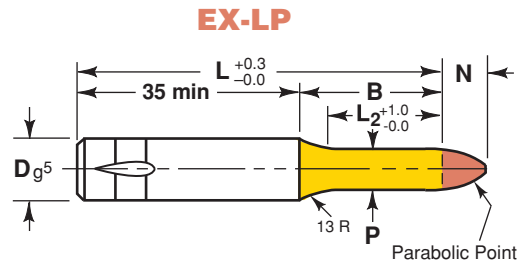
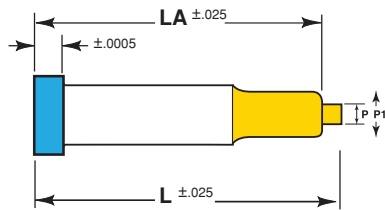

B & L Lengths do not include Pilot Tip N

(ball) EX 21

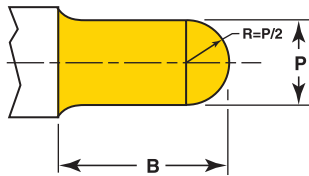

EX 22

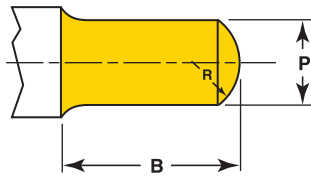

EX 23

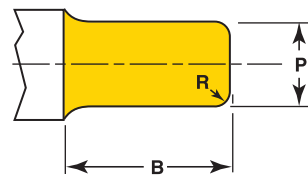

EX 24

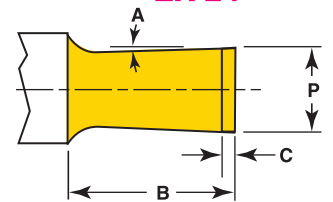

All shank to largest point diameter will be supplied with 13mm radius blend unless otherwise specified. All inside corners will be supplied with 15mm radius blend unless otherwise specified.

For X information see panel on page 39.

EX-25 Pick Up Perforate

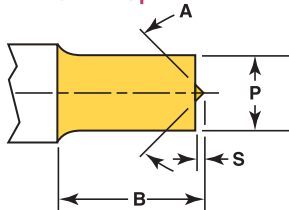

EX-26 Angle Shear

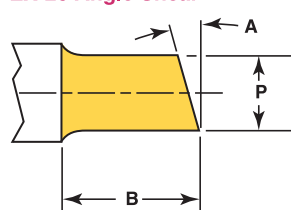

EX-27

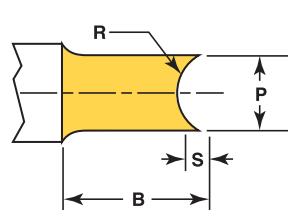

EX-28 Dimple

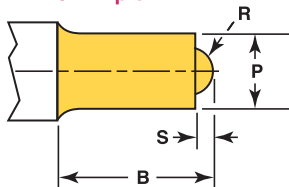

EX-29 Rooftop

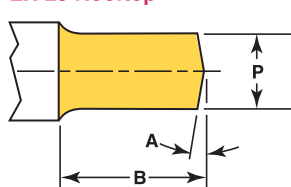

EX-30 Inverted Rooftop

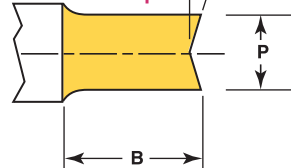

EX-31 Nail Point 4 Sided

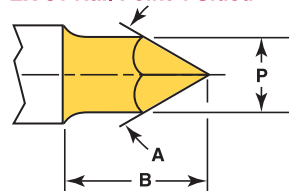

EX-32 Nail Point 3 Sided

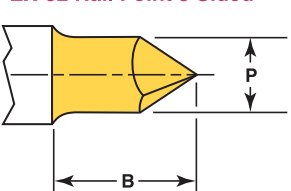

EX-33

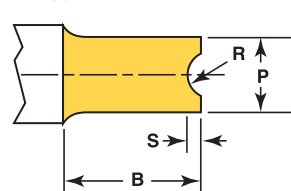

Ex. 1 thru Ex. 33 tips are available on all standard catalog range punches. (Head type, Headless and Bal-Lok Solid and Retracto.) Use caution when using Retracto type in relation to point length (P) and smallest point Ø (P). Some tips are not compatible with Retracto use. (Example # Ex. 31)

When no B (point length) is called out, the standard B for the type punch selected will be supplied. All Ultra Precision style must call out B length as there are more than one standard available for this style punch.

Common type of extrusion punches are shown above and can be configured on any style punch as called out by the customer. Configurations of other styles can be furnished upon receipt of customer drawings with specified tolerances.

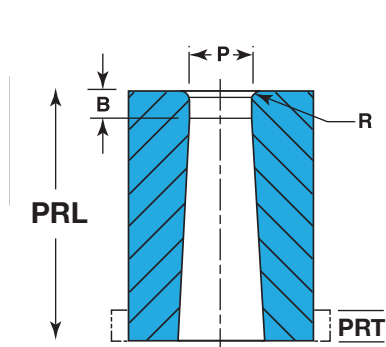

EX-40

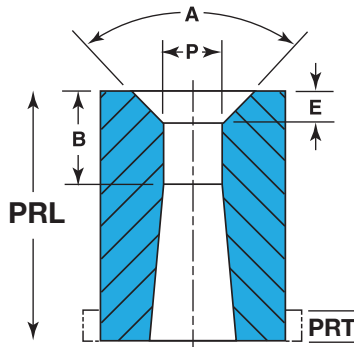

EX-41

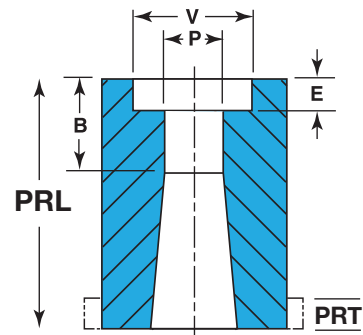

EX-42

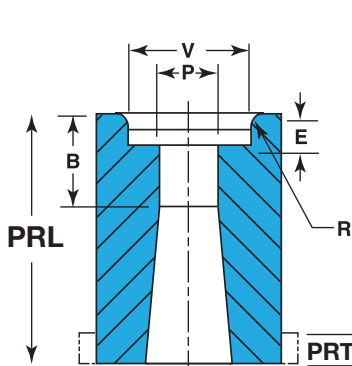

EX-43

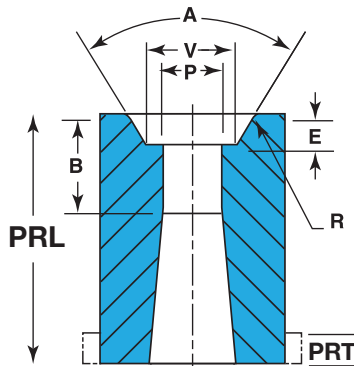

EX-44

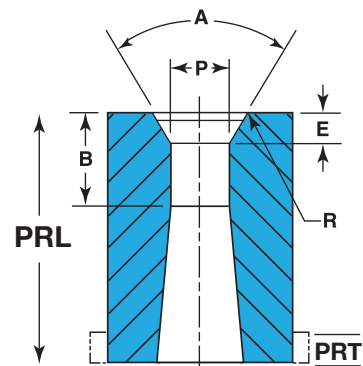

EX-45

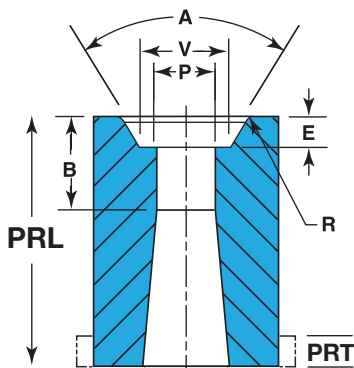

EX-46

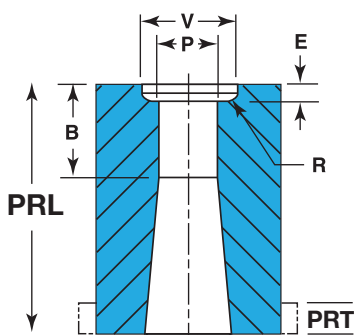

EX-47

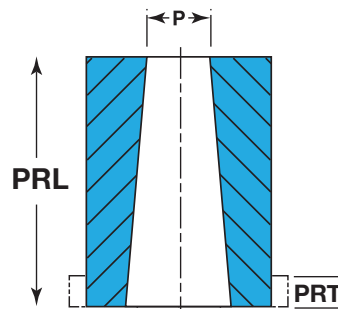

EX-48

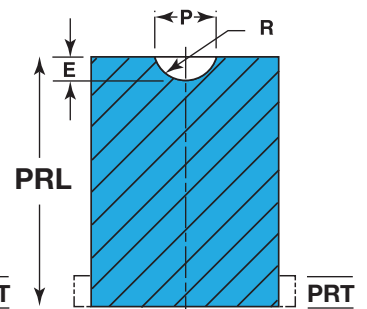

EX-49

Standard materials used on any of these will be M2 with RC of 60-63 unless called out by the customer to be otherwise. Other configurations can be manufactured with drawings submitted by the customer.

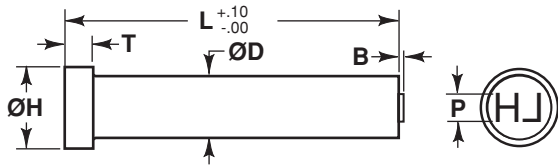

Many custom stamps and marking punches are available from Porter. Please identify punch style as part of the order. All tolerances on punch body other than (L) will be manufactured to catalog standards unless otherwise specified by the customer.



Ordering Example (Specify punch style) Drawings Required

Qty Steel Type Code L P B
12 M-2 ()MP 50 x 80 P=10.00 3.00

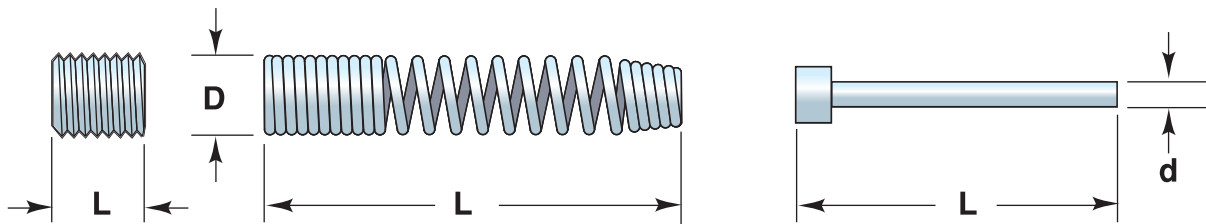
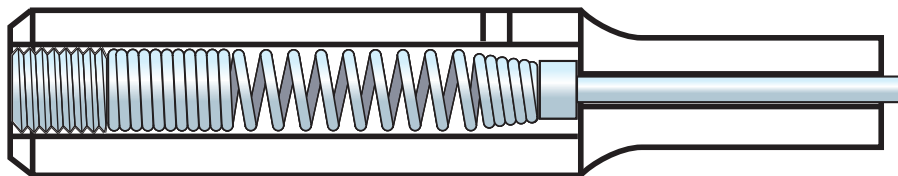

Replacement Ejector Kit	Punch Type		Set Screw Size/Length	Spring			Pin			Pin Extension Length
	Headed	HD Bol-bk		Hole-D	D	L	Hole	L	d	
K2M	5		2.5 x 4.0	2.20	2.10	50	.50	28	.43	.8
K3M	6	10	3.0 x 3.0	2.52	2.40	63	.80	35	.68	.8
K4M	8	10	4.0 x 4.0	3.52	3.30	73	1.16	49	1.04	1.6
K6M	10-13	13-16	5.0 x 5.0	4.42	4.30	73	1.59	49	1.47	1.6
K9M	16-20-25	20-25	6.0 x 6.0	5.52	5.00	80	2.38	56.5	2.26	1.6
K12M	32 &>	32 &>	8.0 x 8.0	7.12	7.00	80	3.17	56.5	3.05	1.6

Kit includes 1 each – set screw
– spring
– pin
Components available as kits or separately.

Ejector Springs and pins are cut to length at assembly.

PORTER® Metric Standard Alterations

Alterations beyond standard ranges listed in the catalog that can be accomplished for a slight additional charge. Alterations beyond those listed consult factory. Standard catalog tolerances are used for all alterations unless otherwise specified

RL = Reduce Length (L)

- Punches- Stock is removed from the point end, also reducing the point length (B)
- Die Buttons-Headless (Excluding Bal-Lok). Stock is removed from the Co-bore end. Head Type with Co-Bore relief. Stock is removed from the I.D. end shortening the (B).
- Taper dies "RL" will not reduce land length

RLB = Reduce length maintain "L₂"

PRL = Precision Reduced Length

- Same as "RL" plus "L" is held to $\pm .02$

RD = Reduced Diameter of Shank or Body

- Max standard reduction 1.0 (Further reduction consult factory). "H" remains the same.

RP = Reduce "P" on Round Punches

- (See chart for standard ranges or consult factory)

RW = Reduce "W" on Shape Punches

- (See chart for standard ranges or consult factory)

RT = Reduce Head Thickness

- Stock removed from the top of the head (Reduces "L")

PRT = Precision Reduced Head Thickness

- Same as RT. "T" is held to $\begin{matrix} +.02 \\ -.00 \end{matrix}$

RH = Reduce Head Diameter

- Max standard reduction 1mm (Further reduction consult factory)

LPC = Longer Point Circular

- Solid Punches Only
- Specify "B" length up to 44 mm
- Minimum body Length shown in catalog (Further reduction consult factory)

LPW = Longer Point Shape

- Solid Punches Only
- Specify "B" length up to 44 mm
- Minimum body length shown in catalog (Further reduction consult factory)

AP = Alter "P" on Round Dies

- Standard dies up to .5 over listed range (Greater increases require "AR")
- Taper dies (See chart)

AW = Alter "W" on Shape Dies

- Standard dies up to .5 over listed range (Greater increases require "AR")
- Taper dies (See chart)

AR = Alter Relief on Co-Bore Dies

- Round Relief Only

AB = Alter Land "B" Length on Die Buttons

- Reduction is from I.D. end shortening "L"

IB = Increase Land "B" on Die Buttons

- Taper Dies {1.3-6.0 (6.0) max}
- {P or W 6.1 and over (13.0) max} [Longer consult factory]
- Co-Bore Dies (Consult factory)

SK = Slug Keeper

- Slug Retention System

AT = Alter Taper

RP-Reduce P Chart

BODY CODE	PRC RC HEC XRC CDRC	PC SC HC XSC CDSC	PLP PP PAP SLP SAP SP CDSAP	HBRC	BRC	BC HBC	HBLP HBAP HBP BLP BAP BP
004		1.30					
005	1.30	1.60	1.60				
006	2.00	2.00	1.60		1.30	1.30	1.40
008	3.00	3.00	1.60				
010	4.00	4.00	1.60	1.80	1.80	1.60	1.60
013	4.00	4.00	3.20	4.00	4.00	4.00	4.00
016	6.00	6.00	6.00	4.00	4.00	4.00	4.00
020	6.00	6.00	6.00	6.00	6.00	6.00	6.00
022	6.00	6.00	6.00				
025	8.00	8.00	8.00	8.00	8.00	8.00	8.00
032	10.00	10.00	10.00	10.00	10.00	10.00	10.00
040	13.00	13.00		12.00	12.00	12.00	12.00

Below 1.60mm L2 = 8 max. Pilots L2 = 10 max.

Below 2.50mm L2 = 19 max. Pilots L2 = 121 max.

RW-Reduce W Chart

BODY CODE	PRO PRR PRS PRF CDRO CDRR CDRS CDRF	PO PR PO PF CDSO CDSR CDSS CDSF	RO RR RS RF XRO XRR XRS XRF	SO SR SS SF XSO XSR XSS XSF	HBRO HBRR HBRS HBRF	HBO HBR HBS HBF	BRO BRR BRS BRF	BO BR BS BF
004		1.06		1.60				
005	1.60	1.60	1.60	1.60				
006	2.00	2.00	2.00	2.00			1.80	1.80
008	3.00	3.00	3.00	3.00				
010	4.00	4.00	4.00	4.00	1.80	1.80	1.80	1.80
013	4.00	4.00	4.00	4.00	4.00	4.00	4.00	4.00
016	6.00	6.00	6.00	6.00	4.00	4.00	4.00	4.00
020	6.00	6.00	6.00	6.00	6.00	6.00	6.00	6.00
022	6.00	6.00	6.00	6.00				
025	6.00	6.00	6.00	6.00	6.00	6.00	6.00	6.00
032	7.20	7.20	7.20	7.20	7.20	7.20	7.20	7.20
040	7.20	7.20	7.20	7.20	7.20	7.20		

Below 1.50mm L2 = 13 max. Below 2.30mm L2 = 19 max.

AP-Alter P Chart

Inch Body Ø	MaxP/W/G
5.0	3.2
6.0	4.0
8.0	6.2
10.0	7.7
13.0	10.4
16.0	12.8
20.0	16.0
25.0	20.0
32.0	25.6
38.0	30.0
40.0	32.0

AR-Alter RØ Chart

Inch Body Ø	MaxP/W/G
8.0	6.6
10.0	8.1
13.0	10.8
16.0	13.3
20.0	16.8
25.0	20.8
32.0	26.4
38.0	30.8
40.0	32.8

VIEWS

All views are shown as in die position view. This is the reflected (thru shank) view for the punch and guide, and is the plain view (thru I.D. end) for the die button (matrix). This view is consistent whether for headed and press fit items or Bal-Lok items.

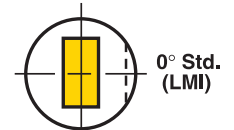
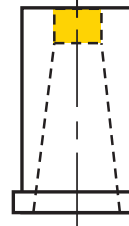
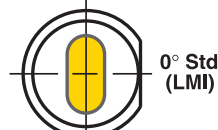
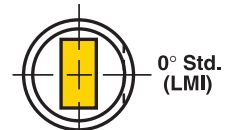
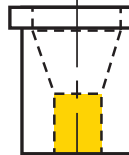
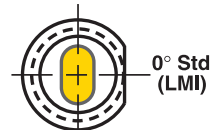
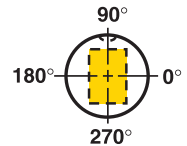
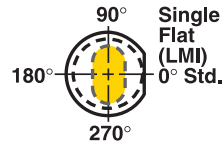

ORIENTATION

On Headed and Press Fit punches, die buttons and guide bushings the standard keying location is at 0° (on the long side of the standard shape). Custom locations are available and called out as the number of degrees counter clockwise from 0° (**Example: LM1@45°**)

BAL-LOK Punches and Die Buttons.

The standard ball-seat keying location is at 90°, (in the end zone if looking at a football field). Custom locations are available and called out as the number of degrees counter clockwise from 0° (**Example: BS@45°**)

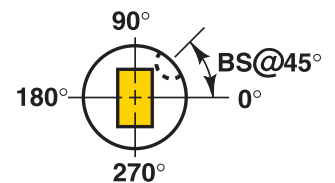
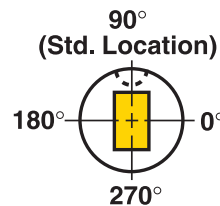

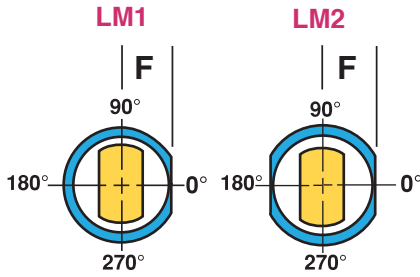

TOLERANCES
 Standard Precision F = $+0.02$ to C/L
 -0.00
 .001/1.000 Parallel
 Ultra Precision F = $+0.01$ to C/L
 -0.00
 0.05/100 Parallel
 Flat length $+0.25$
 -0.00

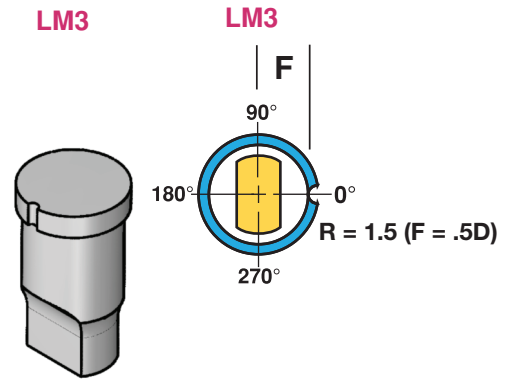

Standard Locating Methods		
Flat		Depth
LM1	F =	.5D
LM2	F =	.5D

All above locating methods are supplied at standard location (0°) "Alternate locations are available at no extra charge" Call out (LM1@90)

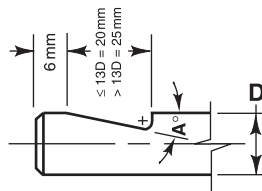

For Shape and Form Headless Punches
Specify LM7 relation to shape.
 Standard location is at 0°
 Alternate angles are available
Specify LM7 A=12°.

STD LM-7	
D	A°
$\le 10\text{mm}$	5°
13mm	7.5°
$\ge 16\text{mm}$	10°

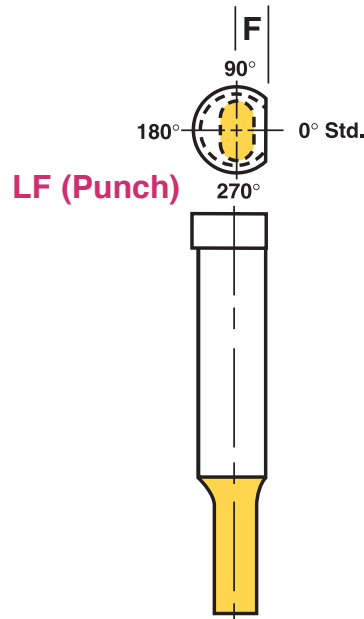
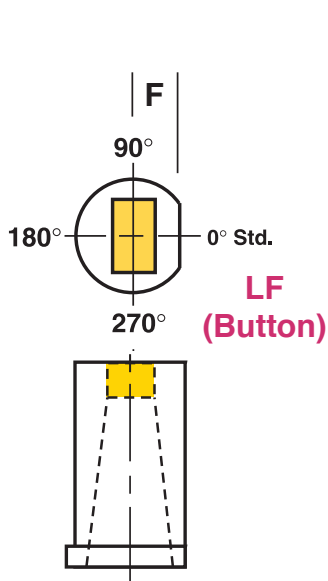

Full Length Die Button		
LF1A	F=	.5D-1.0
LF1	F=	.5D-1.5
LF11	F=	.5D-2.5
LF12	F=	Specify

Full Length Punch Flats		
LF2A	F=	.5D-1.0
LF2	F=	.5D-1.5
LF21	F=	.5D-2.5
LF22	F=	Specify

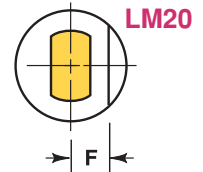
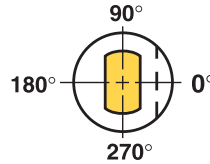
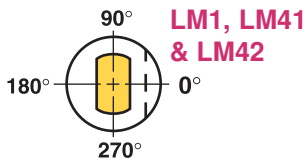
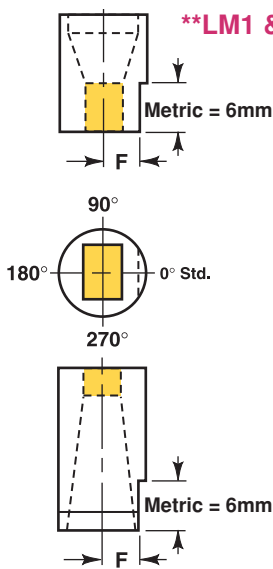

Call Out	D*	Body Diameter "D"														
		.05	.06	.08	10	13	16	20	22	25	32	38	40	45	50	
LM1	6	F =	.5D - 1.5 mm													
LM2	6	F =	.5D - 1.5 mm													
LM20	14	F =			3.5	4.0	5.5	7.0	8.5	9.5	11.0	14.0	17.0	18.0	20.5	23.0
LM41①	6	F =	2.2	2.6	3.5	4.3	5.6	6.9	8.7	9.5	10.8	13.8	16.5	17.4	19.5	21.7
LM42②	6	F =	2.0	2.5	3.5	4.0	5.5	7.0	8.5	9.5	11.0	14.0	17.0	18.0	20.5	23.0

*Additional variations available (consult factory or supply drawings of requirement)

**Above flats available on Cutting end at no charge (Example LM1C) ① Old style standard ② New standard

TOLERANCES ON ALL FLATS

Standard Precision F = $+0.02$ to -0.00 to C/L

.001/1.000 Parallel

Ultra Precision F = $+0.01$ to -0.00 to C/L

0.05/100 Parallel

Flat length $+0.25$ to -0.00

Full Length Die Button		
LF1A	F =	.5D-1.0
LF1	F =	.5D-1.5
LF11	F =	.5D-2.5
LF12	F =	Specify

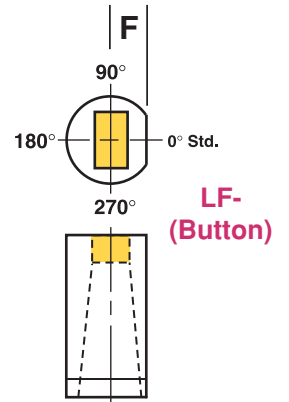

LM43, LM44, LM45, LM46, LM47, LM48, LM49, LM 80 (Flat is on cutting-End)

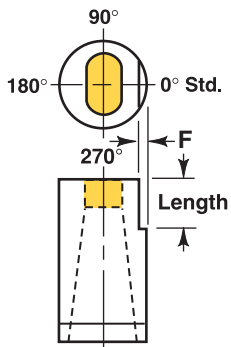

Call Out	F	Length
LM43	.5D-1.5	13
LM44	.5D-1.5	16
LM45	.5D-1.5	20
LM46	SPECIFY	
LM47	.5D-2.5	13
LM48	.5D-2.5	16
LM49	.5D-2.5	20
LM80	.5D-2.5	14

D*	Body Diameter "D"											
	.08	10	13	16	20	22	25	32	38	40	45	50
F =	3.5	4.0	5.5	7.0	8.5	9.5	11.0	14.0	17.0	18.0	20.5	23.0

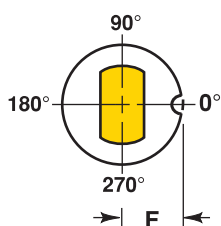

LM (6, 63, 64, 65, 66)

Metric = 3.0 Ø Dowel

Headless Die Button
Guide Bushing

Call Out	Dowel Ø	D =	Body Diameter "D"										
			.05	.06	.08	10	13	16	20	22	25	32 & up	
LM6	3 mm	F =	.5D	.5D	.5D	.5D	.5D	.5D	.5D	.5D	.5D	.5D	.5D
LM63	3 mm	F =	3.5	3.9	4.7	5.5	6.7	.5D	.5D	.5D	.5D	.5D	.5D
LM64	4 mm	F =	4.0	4.4	5.2	6.0	7.2	.5D	.5D	.5D	.5D	.5D	.5D
LM65①	4 mm	F =	3.5	4.0	5.0	6.0	7.5	.5D	.5D	.5D	.5D	.5D	.5D
LM66②	6 mm	F =	-	-	6.2	7.0	8.2	9.0	11.0	12.0	13.5	.5D	.5D

Custom locations (other than 0°, 90°, 180° and 270°) ① Old style standard ② New standard

LM8 = Dowel Slot Custom Location (LM8@45)

Durathane Open End Punch Strippers

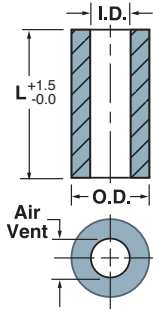

All are oil and solvent resistant 95A durometer. All provide greater pressures than equal sized steel die springs. All are easy to install and dampen vibration. Pop-On's closed end gives more positive stripping and full stripping around periphery of punch point. Open end more economical.

Ordering Example:
Quantity Description
6 05-45

Pop-On Closed End Punch Strippers

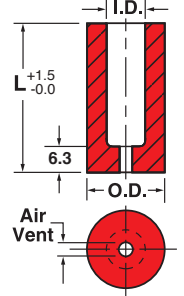

Ordering Example:
Quantity Description
7 M6-45

I.D. mm	O.D. mm	Length L mm	Catalog Number	Approx. Stripping Pressure in kg at deflection of		
				4 mm	7 mm	10 mm
5	18	35	O05-35	125 kg	200 kg	
		45	O05-45	115 kg	175 kg	
		55	O05-55	105 kg	150 kg	
6	19	35	O06-35	140 kg	240 kg	
		45	O06-45	135 kg	230 kg	
		55	O06-55	110 kg	190 kg	240 kg
		65	O06-65	90 kg	130 kg	200 kg
8	21	35	O08-35	160 kg	250 kg	
		45	O08-45	150 kg	225 kg	
		55	O08-55	135 kg	200 kg	
		65	O08-65	120 kg	185 kg	290 kg
		71	O08-71	100 kg	165 kg	270 kg
10	23	35	O10-35	210 kg	350 kg	
		38	O10-38	190 kg	310 kg	
		45	O10-45	175 kg	285 kg	
		47	O10-47	160 kg	270 kg	
		55	O10-55	145 kg	250 kg	325 kg
		65	O10-65	130 kg	220 kg	290 kg
		71	O10-71	115 kg	190 kg	265 kg
13	26	35	O13-35	260 kg	390 kg	
		38	O13-38	225 kg	360 kg	
		45	O13-45	215 kg	340 kg	
		47	O13-47	165 kg	270 kg	
		55	O13-55	150 kg	240 kg	300 kg
		65	O13-65	130 kg	200 kg	250 kg
		71	O13-71	105 kg	160 kg	200 kg
16	30	35	O16-35	300 kg	460 kg	
		38	O16-38	260 kg	420 kg	
		45	O16-45	240 kg	390 kg	
		47	O16-47	235 kg	385 kg	
		55	O16-55	220 kg	360 kg	460 kg
		65	O16-65	200 kg	330 kg	420 kg
		71	O16-71	170 kg	290 kg	360 kg
20	38	38	O20-38	280 kg	420 kg	
		47	O20-47	240 kg	390 kg	
		55	O20-55	200 kg	350 kg	550 kg
		65	O20-65	165 kg	300 kg	450 kg
		71	O20-71	150 kg	270 kg	400 kg
25	50	35	O25-35	1200 kg	1800 kg	
		38	O25-38	1100 kg	1600 kg	
		45	O25-45	1000 kg	1500 kg	
		47	O25-47	900 kg	1400 kg	
		55	O25-55	700 kg	1150 kg	1650 kg
		65	O25-65	600 kg	1000 kg	1450 kg
		71	O25-71	500 kg	850 kg	1300 kg

I.D. mm	O.D. mm	Length L mm	Catalog Number	Approx. Stripping Pressure in kg at deflection of		
				3 mm	6.5 mm	9.5 mm
5	18	35	M05-35	125 kg	200 kg	
		45	M05-45	115 kg	175 kg	
		55	M05-55	105 kg	150 kg	
6	19	35	M06-35	140 kg	240 kg	
		45	M06-45	135 kg	230 kg	
		55	M06-55	110 kg	190 kg	240 kg
		65	M06-65	90 kg	130 kg	200 kg
8	21	35	M08-35	160 kg	250 kg	
		45	M08-45	150 kg	225 kg	
		55	M08-55	135 kg	200 kg	
		65	M08-65	120 kg	185 kg	290 kg
		71	M08-71	100 kg	165 kg	270 kg
10	23	35	M10-35	210 kg	350 kg	
		38	M10-38	190 kg	310 kg	
		45	M10-45	175 kg	285 kg	
		47	M10-47	160 kg	270 kg	
		55	M10-55	145 kg	250 kg	325 kg
		65	M10-65	130 kg	220 kg	290 kg
		71	M10-71	115 kg	190 kg	265 kg
13	26	35	M13-35	260 kg	390 kg	
		38	M13-38	225 kg	360 kg	
		45	M13-45	215 kg	340 kg	
		47	M13-47	165 kg	270 kg	
		55	M13-55	150 kg	240 kg	300 kg
		65	M13-65	130 kg	200 kg	250 kg
		71	M13-71	105 kg	160 kg	200 kg
16	30	35	M16-35	300 kg	460 kg	
		38	M16-38	260 kg	420 kg	
		45	M16-45	240 kg	390 kg	
		47	M16-47	235 kg	385 kg	
		55	M16-55	220 kg	360 kg	460 kg
		65	M16-65	200 kg	330 kg	420 kg
		71	M16-71	170 kg	290 kg	360 kg
20	38	38	M20-38	280 kg	420 kg	
		47	M20-47	240 kg	390 kg	
		55	M20-55	200 kg	350 kg	550 kg
		65	M20-65	165 kg	300 kg	450 kg
		71	M20-71	150 kg	270 kg	400 kg
25	50	35	M25-35	1200 kg	1800 kg	
		38	M25-38	1100 kg	1600 kg	
		45	M25-45	1000 kg	1500 kg	
		47	M25-47	900 kg	1400 kg	
		55	M25-55	700 kg	1150 kg	1650 kg
		65	M25-65	600 kg	1000 kg	1450 kg
		71	M25-71	500 kg	850 kg	1300 kg



HOT FORGED HEADS

OUTLAST THE OTHERS...

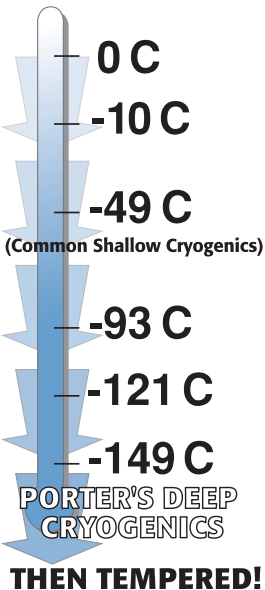

The Benefits

CRYOGENICS process forms very fine carbide particles throughout the material and increases wear resistance.

CRYOGENICS treatment results in a tougher substrate further increasing part life through reduced impact failures.

CRYOGENICS reduces internal stresses or completely eliminates part movement during the machining process.

CRYOGENICS requires only one treatment as it is a through part molecular change and not a surface layer. The results last the life of the tool. Sharpening will NOT eliminate the benefits.

CRYOGENICS is an exclusive combination of deep cryogenics (149C) treatment plus an additional temper during the heat-treating process. This results in internally altering the entire structure of the steel creating a dense and uniform molecular structure. **CRYOGENICS** is not a surface treatment! **CRYOGENICS** increases internal bonding while releasing internal stresses created by previous machining processes. Computer-controlled gradual cooling and warming cycles eliminate the possibility of thermal shock and prevent parts from becoming brittle.

Tin Titanium Nitride

A (PVD) process of placing a thin coating of Titanium Nitride 1-5 microns thick over the working area of the punch.

Benefits

- * Surface hardness of 2300 Vickers
- * Dry coefficient of friction versus steel .4
- * Thermal stability up to 600 C
- * Appears gold in color

TIALN Titanium Aluminum Nitride

A (PVD) process of placing a thin coating of Titanium Aluminum Nitride 2-5 microns thick over the working area of the punch.

Benefits

- * Surface hardness of 3000 Vickers
- * Dry coefficient of friction versus steel .6
- * Thermal stability up to 700 C
- * Appears grey

TICN Titanium Carbonitride

A (PVD) process of placing a thin coating of Titanium Nitride 1-5 microns thick over the working area of the punch.

Benefits

- * Surface hardness of 3000 Vickers harder than Carbide"
- * Dry coefficient of friction versus steel .3
- * Thermal stability up to 400 C
- * More wear resistance than TIN
- * Appears brown or light blue.

P-41

A (PVD) process of placing a thin coating 1-8 microns thick over the working area of the punch.

Benefits

- * Surface hardness of 2000-2800 Vickers
- * Dry coefficient of friction versus steel .1
- * Thermal stability up to 300 C
- * More wear resistant than TICN
- * Specially for non ferrous materials
- * Appears black

Porter Plus (PPC)

A (PVD) process of placing a thin layer of this special coating (2-5 microns thick) over the working area of the punch.

Benefits

- * Surface hardness of 3200 Vickers
- * Dry coefficient of friction versus steel .35
- * Thermal stability up to 1100 C
- * More wear resistant than TICN
- * Appears blue-grey

P-90

A (PVD) process of placing a thin coating 6-8 microns thick over the working area of the punch.

Benefits

- * Surface hardness of 3800 Vickers
- * Dry coefficient of friction versus steel .12
- * Thermal stability up to 400 C
- * More wear resistant coating
- * Appears silver-grey

PZRN

A (PVD) process of placing a thin coating 2-10 microns thick over the working area of the punch.

Benefits

- * Surface hardness of 2800 Vickers
- * Dry coefficient of friction versus steel .5
- * Specially for non-ferrous materials
- * Appears yellow-gold

TICNMP

A (PVD) process of placing a thin coating 2-4 microns thick over the working area of the punch.

Benefits

- * Surface hardness of 3000 Vickers
- * Dry coefficient of friction versus steel .2
- * Specially for Galling issues in steel
- * Appears bronze

CRN

A (PVD) process of placing a thin coating 2-4 microns thick over the working area of the punch.

Benefits

- * Surface hardness of 2300 Vickers
- * Dry coefficient of friction versus steel .3
- * Specially for forming punches
- * Appears silver

2734 Banning Road
Cincinnati, OH 45253-8706
Ph: (513) 923-3777
Fax: (513) 923-1111



PORTER PRECISION PRODUCTS
Blank Punch Sketch Tool
Porter@PorterPunch.com or Georgia@PorterPunch.com

660 James Road
Alpharetta, GA 30004
Ph: (770) 751-7234
Fax: (770) 751-7238

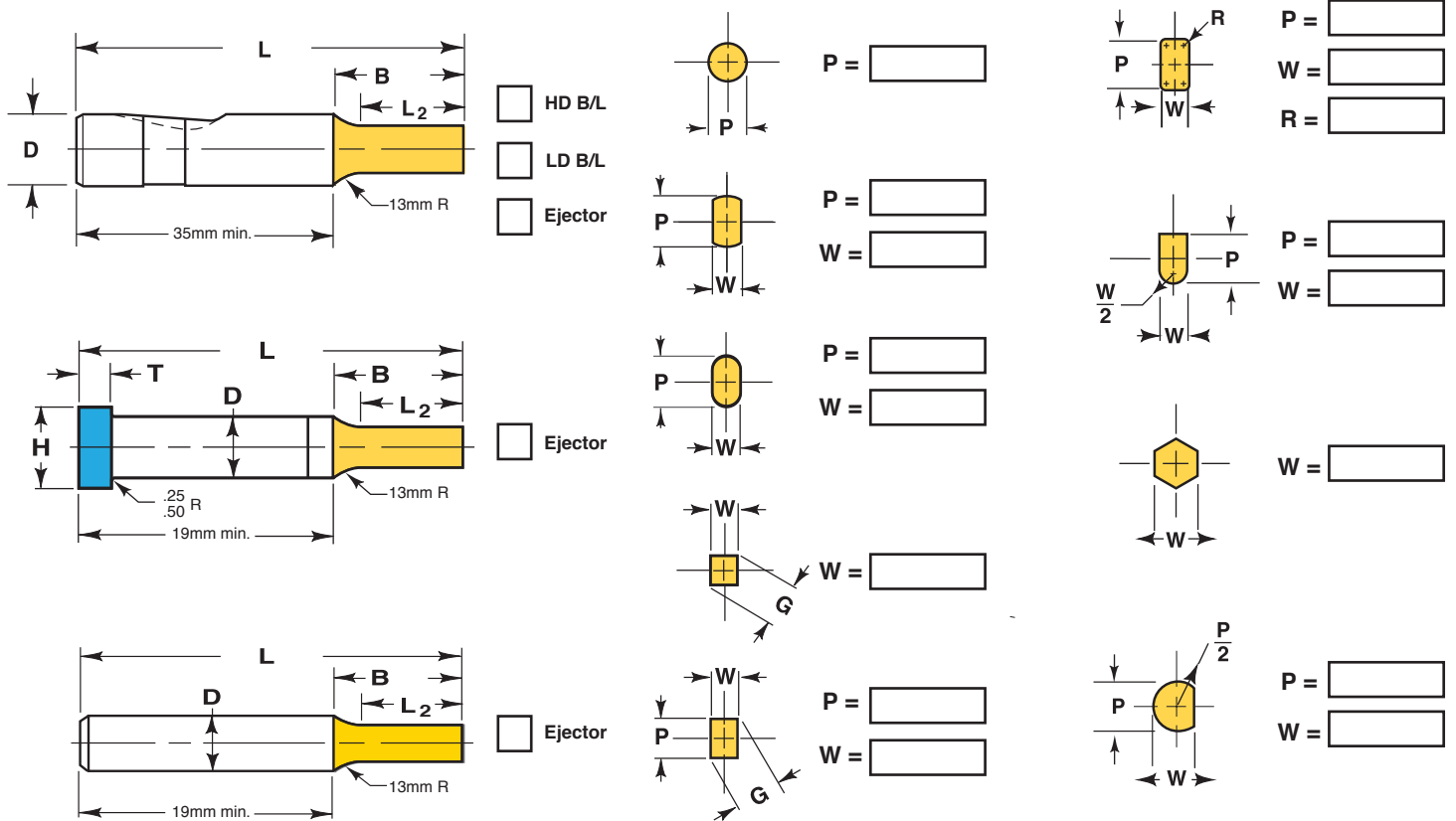

Locating Devices

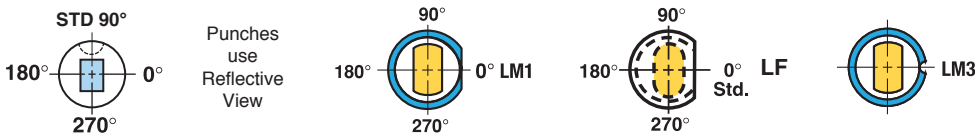

Nose Point Alteration

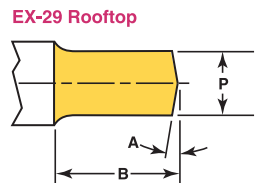

*All tolerances will be held to industry standards unless otherwise specified

Company Name		Tool #	Part #/ Det #		Description (Porter Precision Products)	
Body Dia "D"	Length "L"	Material	Nose Length "B" or L2	Coating	Locating Device & Location	"T" if not Std (Xtreme)
Notes and or other Alteration requests						Qty <input type="text"/>

2734 Banning Road
Cincinnati, OH 45253-8706
Ph: (513) 923-3777
Fax: (513) 923-1111



PORTER PRECISION PRODUCTS

Blank Button Sketch Tool

Porter@PorterPunch.com or Georgia@PorterPunch.com

660 James Road
Alpharetta, GA 30004
Ph: (770) 751-7234
Fax: (770) 751-7238

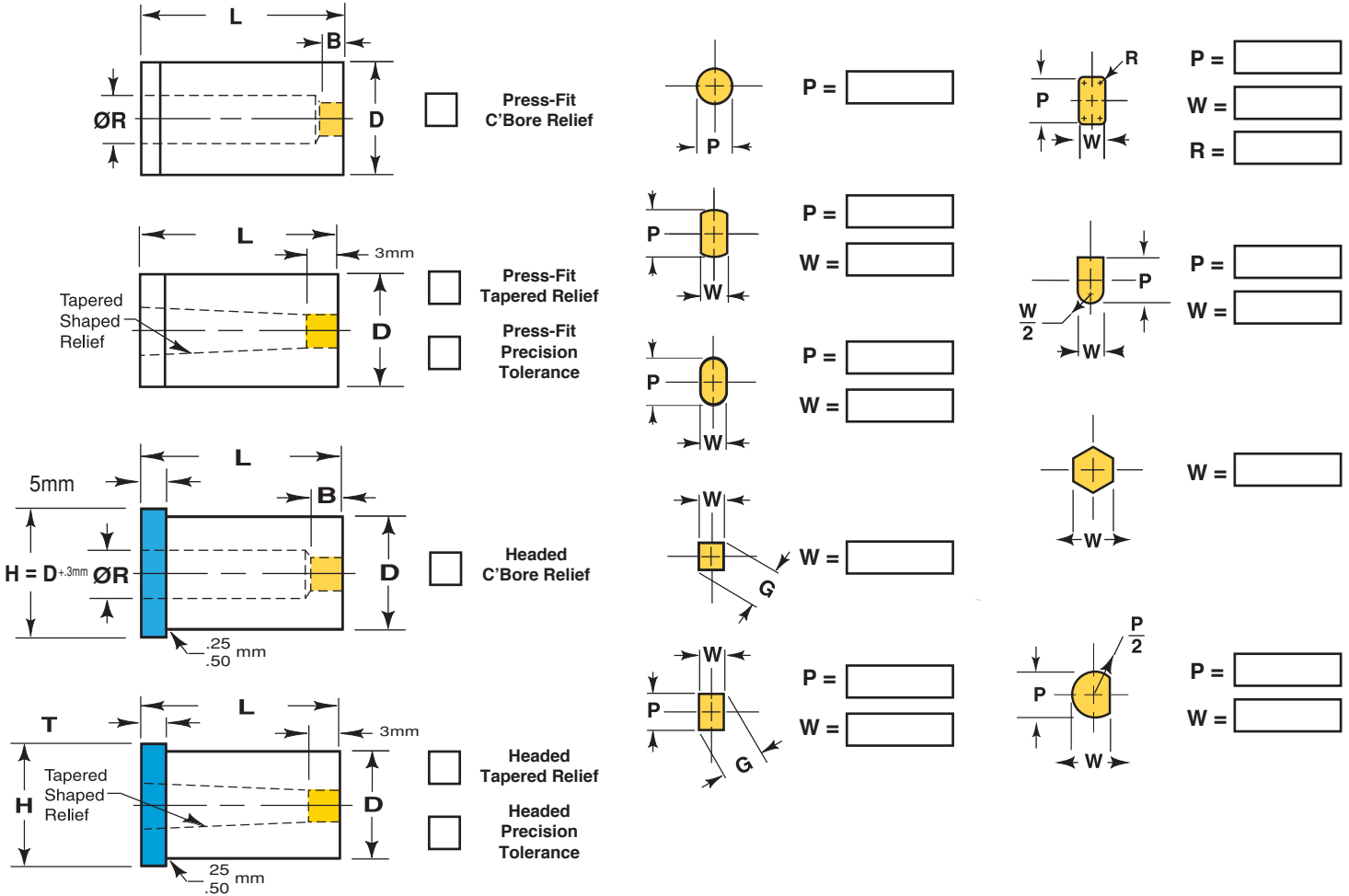

Locating Devices

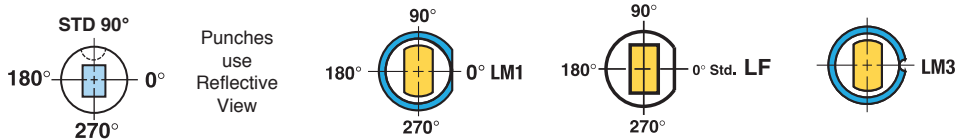

LM3 Std Dowel is .3mm Dia.
Custom Dowel Size (Dia.)

**All tolerances will be held to industry standards unless otherwise specified*

Company Name	Tool #	Part #/ Det #	Description (Porter Precision Products)			
Body Dia "D"	Length "L"	Material	Nose Length "B" or L2	Coating	Locating Device & Location	"T" if not Std (Xtreme)
Notes and or other Alteration requests						
						Qty <input type="text"/>

Policy

Porter Precision Products guarantees its products to meet catalog specifications which are interchangeable and equivalent to I.S.O. standards. Print items and special description call-outs will be manufactured to the customer's specifications. No other warranties are expressed or implied.

All dimensions not specifically toleranced will be manufactured to industry (our Catalog) standards, regardless of the decimal place call-out. To eliminate misunderstandings, include tolerance charts on your prints or specifically tolerance critical dimensions.

Steel type is to be specified by the customer. If not specified, we will supply the first material listed in the catalog. It is always best to include your material choice in the part call-out as shown in the ordering examples.

Terms & Conditions

Prices- Net each and subject to change without notice.

Minimum Order Charge- There is no minimum order charge on manufactured items.

Terms-Net 30 Days, F.O.B. Shipping point

we also accept American Express, Master Card, and Visa

Credit- Orders are subject to the approval of our credit department. To expedite new accounts, furnish bank reference and three supplier references.

Returns- Credit claims for our manufactured items must be made within 45 days of shipment date. Stock blanks are returnable for credit less a 25% restocking fee. If they are exchanged for items of equal or greater value they can be returned for full credit. All items altered by us to the customer's specifications are the property of the buyer and are not returnable unless they do not meet catalog or print tolerances. Any item that has been altered by the customer is the said customer's responsibility and is for no reason returnable.

Over/Under Shipments- Manufactured products can vary up to 10% of the quantity ordered depending on the complexity of the part. If no variation is acceptable this information must be supplied to us at the time of quoting.

Cancellation- The customer will be responsible for a pro-rated charge to cover any work completed prior to cancellation.

Infringements- Customer shall assume all responsibility and undertake the defense of all lawsuits for infringements on patents brought against Porter Precision Products for the manufacture of products named in an order when said products are made according to drawings, samples, and/or descriptions that have been supplied by the customer.

Items supplied but not manufactured by us- All policies/terms & conditions set forth by the manufacturer of said items are applicable. Contact Porter for information regarding various policies.



PORTER PRECISION PRODUCTS CO.

Corporate Office & Manufacturing Plant

2734 Banning Rd., Cincinnati, Ohio 45253-8706

Ph: (513) 923-3777 • Fax: (513) 923-1111

Toll Free (800) 543-7041

Porter@porterpunch.com

Georgia Manufacturing Plant

660 James Rd., Alpharetta, Ga. 30004

Ph: (770) 751-7234 • Fax: (770) 751-7238

Toll Free: (800) 437-5185

Georgia@porterpunch.com

Canada Plant

30 Duke Street West, Suite #503

Kitchener, Ontario, Canada N2H 3W5

Ph: (519) 746-3130 • Fax: (519) 746-6960

Toll Free: 1-800-265-8844

Canada@porterpunch.com



www.porterpunch.com

World Class Products That Perform!