

PORTER. PRECISION INCH



PORTER PRECISION PRODUCTS CO.

HEAD TYPE PUNCHES

4	Standard Retracto Punches and Blanks	R	RQ
5	Ultra Precision Retracto Punches & Blanks	PR	PRQ
6	Standard Solid Punches & Blanks	S	SQ
7	Ultra Precision Solid Punches and Blanks	P	PQ
8	Xtreme Retracto Punches & Blanks	XR	XRQ
9	Xtreme Solid Punches & Blanks	XS	XSQ
10	Standard Pilot Punches	SP	SAP
11	Ultra Precision Pilot Punches	PP	PAP
12	Standard and Ultra Precision Sur-Align Pilots	SAPQ	SAPN...PAPQ...PAPN

BAL-LOK AND HEADLESS PUNCHES

13	Headless Retracto & Solid Punches & Blanks	HR	H	HRQ	HQ
22	Heavy Duty Retracto Punches & Blanks	HBR	HBRB		
23	Heavy Duty Solid Punches & Blanks	HB	HBB		
24	Heavy Duty Knobs & Bal-Lok Release Tools	HBKR	HBK	BRT	
25	Heavy Duty Pilots	HBP	HBAP		
26	Light Duty Retracto Punches & Blanks	BR	BRB		
27	Light Duty Solid Punches & Blanks	B	BB		
28	Light Duty Knobs	BKR	BK		
29	Light Duty Pilots	BP	BAP		

PERFORATORS, HOLDERS, AND SUPPORT SLEEVES

18	Headed Perforators	HP	NPP	NAP
19	Support Sleeves	CQ	BHQ	

DIE BUTTONS

14	Headed & Headless Counterbore Dies	HND	ND		
15	Standard Taper Dies & Blanks	HDT	DT	HNDW	NDW
16	Precision Taper Dies	HPD	PD		
17	Bal-Lok Die Buttons & Blanks – Steel Guide Bushings	BD	BDW	GL	GD...GU

RETAINERS

20	Head Type Retainers	ISR	IRR
21	Bal-Lok Retainers	IHR	ILR

ADDITIONAL ITEMS AND INFORMATION

30	Standard Forms
31	Standard Forms
32	Extrusion Tips
33	Extrusion Tips & Punch Shear
34	Extrusion Dies
35	Stamps & Retracto Replacement Components
36	Standard Alterations
37	Views
38	Locating Flats
39	Locating Flats & Dowels
40	Urethane Strippers
41	Treatments
42	Coatings

STANDARD CATALOG ITEMS (Up to 32 mm Ø Body)
NUMBER OF WORK DAYS TO SHIPMENT

Description	1-19 Pieces	20-50 Pieces
Blanks, Steel Springs, Urethane	1	1
Round Punches (Circular Point)	2	5
Round Dies (Circular ID)	2	5
Shape Punches (flatted round, oblong, square, rectangle)	4	7
Shape Dies (flatted round, oblong, square, rectangle)	4	7
'Z' Shapes - (01 - 16) Page 30 & 31	6	9
'Z' Shapes - (All Others) Page 30 & 31	8	11
Pilots	3	5
Knob Style Punches - Pages 24 & 28	8	12
Guide Bushings - Page 17	3	10
Durable Line - Pages 19 & 20	Quote	Quote
'EX' Shapes, Pages 32 – 34	5	7
Xtreme Punch - Pages 8 – 9	3	10
Specials	Quote	Quote
Coatings - Page 42	Add 5 Days	Add 5 Days
Locating Methods - Pages 38 & 39	Add 0 Days	Add 1 Day
Standard Alterations - Page 36		
Group (1) Below - up to 2 alterations	Add 0 Days	Add 0 Days
Group (2) Below - each alteration	Add 1 Day	Add 2 Days
Group (1) - RL/RT/RH/LPC/LPW/RP/RW/AP/AW & (AB/IB - for Taper Relief Die Matrix)		
Group (2) - PRL/RD/PRT/AR/SK & (AB/IB - for Stepped Relief Die Matrix)		

Allow Additional Time for Multiple Line Item Orders Over 150 Total Pieces Round, or 50 Total Pieces Shape - or Combinations Thereof - Call For Quote

**NOTE: THE DAY OF RECEIPT OF THE ORDER IS NOT CONSIDERED
A WORK DAY**

WILL SHIP TODAY

ORDER MUST BE ENTERED BY NOON E.S.T. - and confirmed by phone

Up to Ø 25 mm body

M2 steel only;

Catalog Rounds - up to 9 pieces with maximum of one alteration

Catalog Shapes - (flat round, oblong, square and rect.) up to 4 pieces/1 alteration

Locking Methods - single and double flats

Items not available for this service

Knob Style Punches

Coatings/Treatments

Dowel Slots/Full Length Body Flats

Durable Line (catalog pages 18 & 19)

Extrusion Line

Pilot Punches over 92 mm "L"

Advise Shipping Method - if not specified will ship FedX or UPS next day delivery

A.M. or Saturday delivery if available

Additional Cost -

Round items - add 100% to list price (no minimum charge)

Shape items - add 50% to list price (no minimum charge)

WILL SHIP TOMORROW

ORDER MUST BE ENTERED BY NOON E.S.T. - and confirmed by phone

Same limitations as "Will Ship Today", PLUS

Up to 19 piece quantities

Up to three alterations

All locking methods available

Additional Cost - add 25% per line item (no minimum charge)

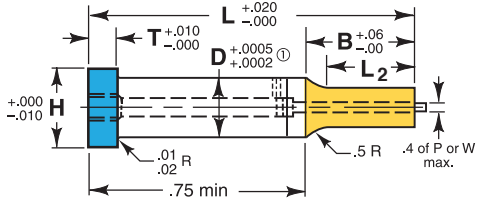

Ordering Example:

Qty Steel Type D B L P
13 M2 RC 50 S x 3.00 P .470

Steel: D2 Rc 58-61,
M2 Rc 60-63
Heads Rc 40-55 (1" Ø and smaller
and L > 2")

TOLERANCES

Round P $\pm .0005$ $\text{Ⓢ} .0005$ P to D

Shape P, W $\pm .0005$ $\text{Ⓢ} .001$ P, W to D

① D Tol = $\pm .0006$
 $\pm .0002$

Back Draft .001/inch L2 max.

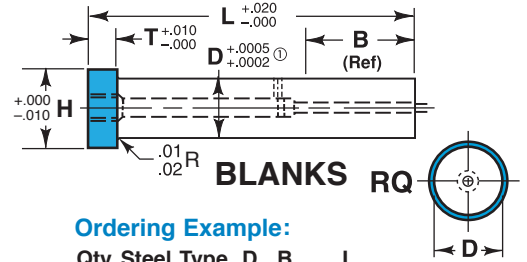

Ordering Example:

Qty Steel Type D B L
13 M2 RQ 37 C x 3.00

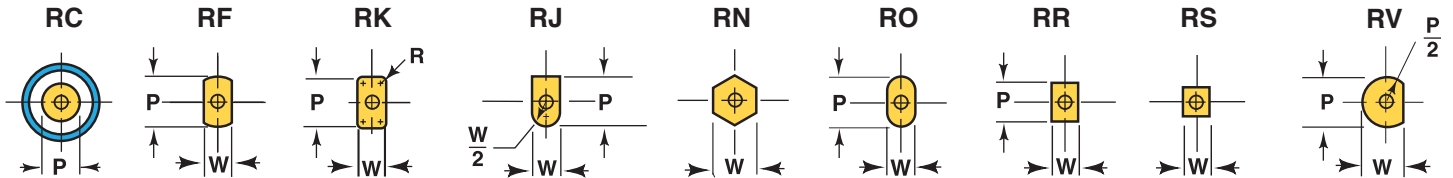

For additional standard forms and configurations see pages 30 - 33.

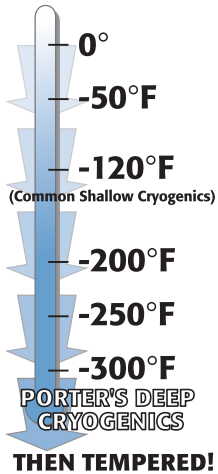

All Standard Punches up to 1" Dia. are "Deep Cryogenically" treated for
1. Wear
2. Toughness
3. Dimensional Stability

See page 41 for more details.

Reflected View

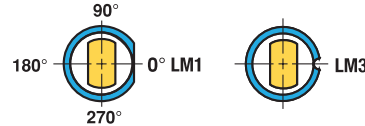

Optional Locating Methods See Page 38 & 39 for details and options.

Shank		Head		Point Length B				Lengths L in .25" Increments	Point			Replacement Retrako Kit*
D	Code No.	H	T	Standard S	Alternates B(.75) C(1.0) D(1.25) E(1.5)				Round Range P	Min W	Shape Max P/G	
.1875	18	.312	.125	.437	●			1.50 thru 3.00	.062 - .1874	.062	.1875	K2I
.2500	25	.375	.125	.500	●			1.50 thru 3.00	.093 - .2499	.093	.2500	K3I
.3125	31	.437	.125	.562	●	●		1.50 thru 4.00	.125 - .3124	.125	.3125	K4I
.3750	37	.500	.188	.625	●	●		1.75 thru 4.00	.187 - .3749	.187	.3750	K6I
.4375	43	.562	.188	.750	●	●	●	2.00 thru 4.00	.187 - .4374	.187	.4375	K6I
.5000	50	.625	.188	.812	●	●	●	2.00 thru 5.00	.250 - .4999	.187	.5000	K6I
.6250	62	.750	.250	.937	●	●	●	2.00 thru 4.25	.375 - .6249	.250	.6250	K9I
.7500	75	.875	.250	1.062	●	●	●	2.25 thru 4.25	.500 - .7499	.312	.7500	K9I
.8750	87	1.000	.250	1.125	●	●	●	2.50 thru 4.00	.594 - .8749	.312	.8750	K9I
1.0000	100	1.125	.250	1.250	●	●	●	2.50 thru 4.00	.687 - .9999	.312	1.0000	K9I
1.2500	125 ①	1.375	.250	1.375	●	●	●	2.50 thru 4.00	.700 - 1.2499	.312	1.2500	K12I
1.5000	150 ①	1.625	.250	1.375	●	●	●	2.50 thru 3.75	.750 - 1.4999	.312	1.5000	K12I
1.7500	175 ①	1.875	.250	1.375	●	●	●	2.50 thru 3.75	1.000 - 1.7499	.350	1.7500	K12I
2.0000	200 ①	2.125	.250	1.375	●	●	●	2.50 thru 3.75	1.188 - 1.9999	.400	2.0000	K12I

*Ejector Kits available see page 35 for details.
Punches .1875 and 1.25 and larger = No side hole.
Ejector Punches $\leq 2.00L$ or $> 4.00L$ = No side hole.

D2 up to 1.00 Ø 4.00 long

All Lengths under 4.50 in Light Blue Panel have Hot Forged Heads for added strength and toughness.

Standard Alterations are changes that are beyond the ranges listed in the catalog that can be altered for a minimal charge. See page 36.

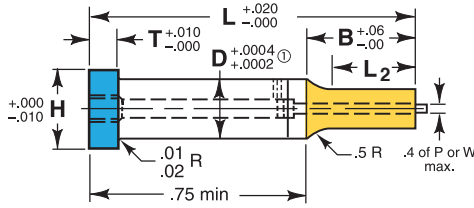

Steel: D2 Rc 58-61, M2 Rc 60-63
PM4, Rc 63-65

Heads Rc 40-55 (1" Ø and smaller and L > 2")

TOLERANCES

D ≤ 1.25 P,W $\begin{matrix} +.0002 \\ -.0000 \end{matrix}$ $\text{Ⓢ} \begin{matrix} .0003 \\ P,W \text{ to } D \end{matrix}$

D > 1.25 P,W $\begin{matrix} +.0005 \\ -.0000 \end{matrix}$ $\text{Ⓢ} \begin{matrix} .0005 \\ P,W \text{ to } D \end{matrix}$

① D Tol = $\begin{matrix} +.0006 \\ +.0002 \end{matrix}$

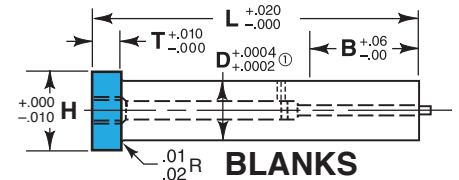

BLANKS



Ordering Example:

Qty Steel Type D B L P
6 PM4 PRC 50 C x 3.00 P.470

Ordering Example:

Qty Steel Type D B L
7 PM4 PRQ 37 D x 3.00

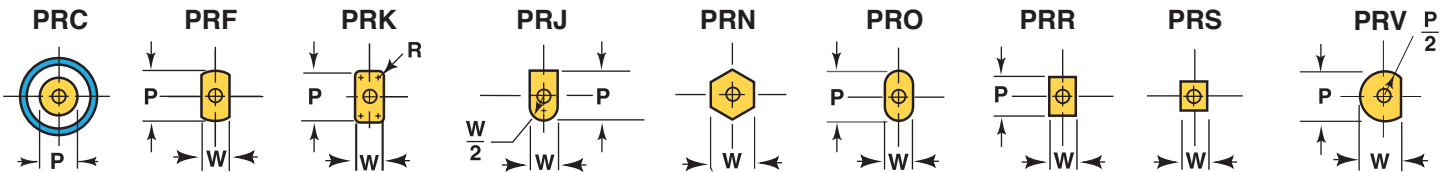

For additional standard forms and configurations see pages 30 - 33.

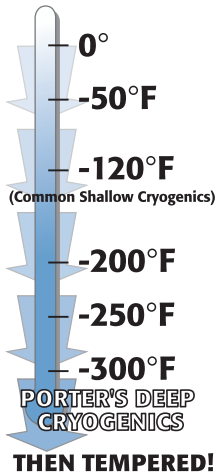

All Standard Punches up to 1" Dia. are "Deep Cryogenically" treated for
1. Wear
2. Toughness
3. Dimensional Stability

See page 41 for more details.

Reflected View

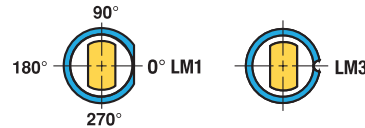

Optional Locating Methods See Page 38 & 39 for details and options.

Shank		Head		Point Length B					Lengths L in .25" Increments	Point			Replacement Retrako Kit*
D	Code No.	H	T	A(.50)	B(.75)	C(1.0)	D(1.25)	E(1.5)		Round	Shape		
										Range P	Min W	Max P/G	
.1875	18	.312	.125	•	•	•	•	•	.062 - .1874	.093	.1875	K2I	
.2500	25	.375	.188	•	•	•	•	•	.093 - .2499	.093	.2500	K3I	
.3125	31	.437	.188	•	•	•	•	•	.125 - .3124	.125	.3125	K4I	
.3750	37	.500	.188	•	•	•	•	•	.187 - .3749	.187	.3750	K6I	
.4375	43	.562	.188	•	•	•	•	•	.187 - .4374	.187	.4375	K6I	
.5000	50	.625	.188	•	•	•	•	•	.225 - .4999	.250	.5000	K6I	
.6250	62	.750	.188	•	•	•	•	•	.310 - .6249	.282	.6250	K9I	
.7500	75	.875	.188	•	•	•	•	•	.390 - .7499	.312	.7500	K9I	
.8750	87	1.000	.188	•	•	•	•	•	.343 - .8749	.312	.8750	K9I	
1.0000	100	1.125	.188	•	•	•	•	•	.485 - .9999	.375	1.0000	K9I	
1.2500	125 ①	1.375	.188	•	•	•	•	•	.625 - 1.2499	.375	1.2500	K12I	
1.5000	150 ①	1.625	.188	•	•	•	•	•	.750 - 1.4999	.375	1.5000	K12I	

*Ejector Kits available see page 35 for details.
Punches .1875 and 1.25 and larger = No side hole.
Ejector Punches ≤ 2.00L or > 4.00L = No side hole.

D2 & PM4 up to 1.00 Ø 4.00 long
PM4 = No side hole.

All Lengths under 4.50 in Light Blue Panel have Hot Forged Heads for added strength and toughness.

Standard Alterations are changes that are beyond the ranges listed in the catalog that can be altered for a minimal charge. See page 36.

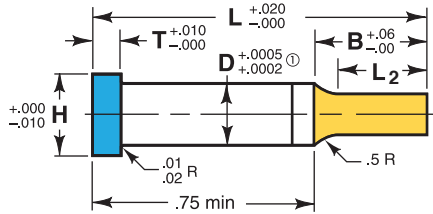

Ordering Example:

Qty Steel Type D B L P
13 M2 SC 50 S x 3.00 P .470

Steel: D2 Rc 58-61, M2 Rc 60-63
Heads Rc 40-55 (1" Ø and smaller and L > 2")

TOLERANCES

Round P $\begin{matrix} +.0005 \\ -.0000 \end{matrix}$ $\text{Ⓞ} .0005$ P to D

Shape P, W $\pm .0005$ $\text{Ⓞ} .001$ P, W to D

① D Tol = $\begin{matrix} +.0006 \\ +.0002 \end{matrix}$

Back Draft .001/inch L2 max.

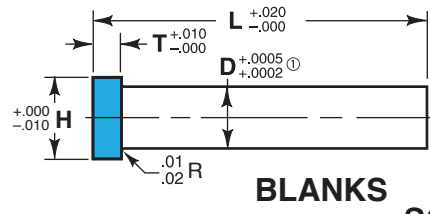

BLANKS

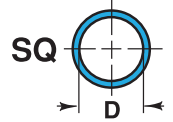

Ordering Example:

Qty Steel Type D L
13 M2 SQ 25 x 2.00

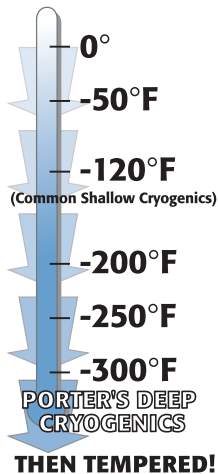
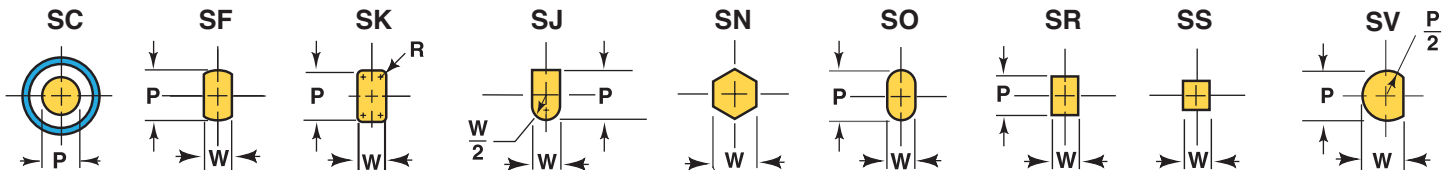

All Standard Punches up to 1" Dia. are "Deep Cryogenically" treated for

1. Wear
2. Toughness
3. Dimensional Stability

See page 41 for more details.

For additional standard forms and configurations see pages 30 - 33.

Reflected View



Optional Locating Methods See Page 38 & 39 for details and options.

Shank		Head		Point Length B				Lengths L in .25" Increments	Point		
D*	Code No.	H	T	Standard	Alternates				Round	Shape	
				S	B(.75)	C(1.0)	D(1.25)		E(1.5)	Range P	Min W
.1250	12	.250	.125	.437	•				.062 - .1249	.062	.1250
.1875	18	.312	.125	.437	•				.062 - .1874	.062	.1875
.2500	25	.375	.125	.500	•				.062 - .2499	.062	.2500
.3125	31	.437	.125	.562	•	•			.093 - .3124	.093	.3125
.3750	37	.500	.188	.625	•	•			.125 - .3749	.125	.3750
.4375	43	.562	.188	.750	•	•	•		.187 - .4374	.187	.4375
.5000	50	.625	.188	.812	•	•	•		.250 - .4999	.187	.5000
.6250	62	.750	.250	.937	•	•	•		.375 - .6249	.250	.6250
.7500	75	.875	.250	1.062	•	•	•		.500 - .7499	.312	.7500
.8750	87	1.000	.250	1.125	•	•	•	•	.562 - .8749	.312	.8750
1.0000	100	1.125	.250	1.250	•	•	•	•	.625 - .9999	.312	1.0000
1.1250	112	1.250	.250	1.375	•	•	•	•	.625 - 1.1249	.312	1.1250
1.2500	125 ①	1.375	.250	1.375	•	•	•	•	.625 - 1.2499	.312	1.2500
1.3750	137 ①	1.500	.250	1.375	•	•	•	•	.719 - 1.3749	.312	1.3750
1.5000	150 ①	1.625	.250	1.375	•	•	•	•	.750 - 1.4999	.312	1.5000
1.7500	175 ①	1.875	.250	1.375	•	•	•	•	1.000 - 1.7499	.350	1.7500
2.0000	200 ①	2.125	.250	1.375	•	•	•	•	1.188 - 1.9999	.400	2.0000

*D2 up to 1.00 Ø 4.00 Long

All Lengths under 4.50 in Light Blue Panel have Hot Forged Heads for added strength and toughness.

Standard Alterations are changes that are beyond the ranges listed in the catalog that can be altered for a minimal charge. See page 36.

PORTER® Ultra Precision Headed Punch (P-)

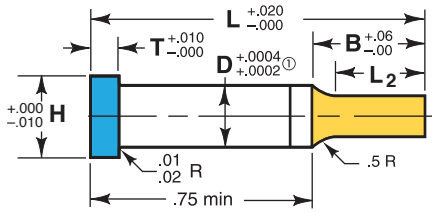

Ordering Example:

Qty Steel Type D B L P
6 M2 PC 50 A x 3.25 P .375

Steel: D2 Rc 58-61, M2 Rc 60-63
PM4, Rc 63-65
Heads Rc 40-55 (1" Ø and smaller and L > 2")

TOLERANCES

D ≤ 1.25 P,W $\begin{matrix} +.0002 \\ -.0000 \end{matrix}$ $\text{Ⓢ} \begin{matrix} .0003 \\ P,W \text{ to } D \end{matrix}$
D > 1.25 P,W $\begin{matrix} +.0005 \\ -.0000 \end{matrix}$ $\text{Ⓢ} \begin{matrix} .0005 \\ P,W \text{ to } D \end{matrix}$

① D Tol = $\begin{matrix} +.0006 \\ +.0002 \end{matrix}$

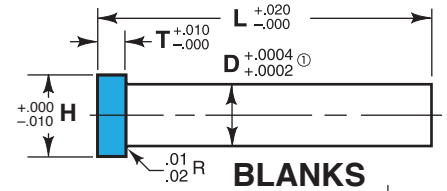

BLANKS

Ordering Example:

Qty Steel Type D L PQ
6 M2 PQ 50 x 3.00

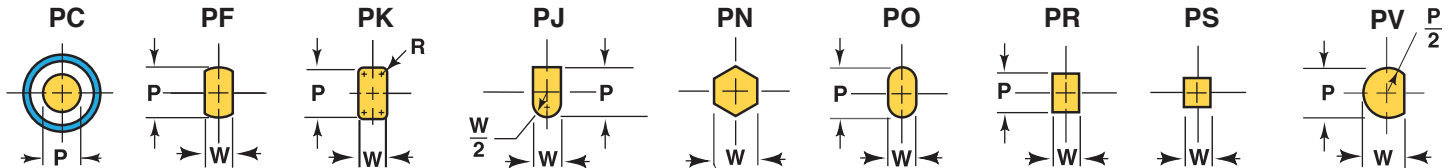
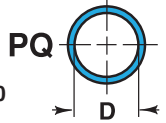

For additional standard forms and configurations see pages 30 - 33.

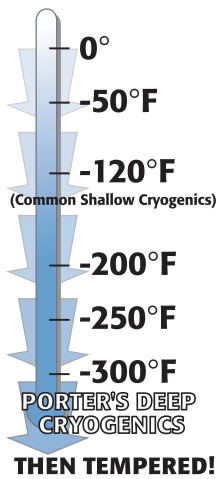

All Standard Punches up to 1" Dia. are "Deep Cryogenically" treated for

1. Wear
2. Toughness
3. Dimensional Stability

See page 41 for more details.

Reflected View

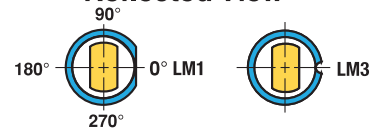

Optional Locating Methods See Page 38 & 39 for details and options.

Shank		Head		Point Length B					Lengths L in .25" Increments	Point Round	Point Shape	
D*	Code No.	H	T	A(.50)	B(.75)	C(1.0)	D(1.25)	E(1.5)		Range P	Min W	Max P/G
.1250	12	.250	.125	•	•	•	•		1.50 thru 3.25	.062 - .1249	.062	.1250
.1875	18	.312	.125	•	•	•	•	•	1.50 thru 4.00	.062 - .1874	.062	.1875
.2500	25	.375	.188	•	•	•	•	•	1.50 thru 4.00	.062 - .2499	.062	.2500
.3125	31	.437	.188	•	•	•	•	•	1.50 thru 4.25	.093 - .3124	.093	.3125
.3750	37	.500	.188	•	•	•	•	•	1.50 thru 6.00	.125 - .3749	.125	.3750
.4375	43	.562	.188	•	•	•	•	•	1.50 thru 4.25	.187 - .4374	.187	.4375
.5000	50	.625	.188		•	•	•	•	1.50 thru 6.00	.225 - .4999	.187	.5000
.6250	62	.750	.188		•	•	•	•	2.00 thru 5.00	.310 - .6249	.250	.6250
.7500	75	.875	.188			•	•	•	2.00 thru 5.00	.390 - .7499	.312	.7500
.8750	87	1.000	.188		•	•	•	•	1.75 thru 4.00	.343 - .8749	.312	.8750
1.0000	100	1.125	.188		•	•	•	•	2.00 thru 4.25	.485 - .9999	.375	1.0000
1.2500	125 ①	1.375	.188		•	•	•	•	2.00 thru 4.25	.625 - 1.2490	.500	1.2500
1.3750	137 ①	1.500	.188			•	•	•	2.25 thru 4.00	.719 - 1.3740	.516	1.3750
1.5000	150 ①	1.625	.188			•	•	•	2.25 thru 4.00	.750 - 1.4990	.563	1.5000

*PM4 & D2 up to 1.00 Ø 4.00 Long.

P below .060 Ø available B=1.00 max W below .093 Ø available B=1.00 max
P below .050 Ø available B=.75 max W below .060 Ø available B=.75 max

All Lengths under 4.50 in Light Blue Panel have Hot Forged Heads for added strength and toughness.

Standard Alterations are changes that are beyond the ranges listed in the catalog that can be altered for a minimal charge. See page 36.

PORTER Xtreme Retrako Punches (XR-)

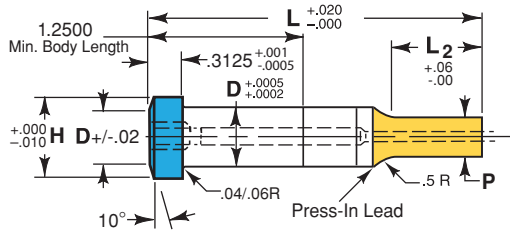

**Steel: PM4 Rc 60-63
Heads Rc 40-55**

TOLERANCES

Round P $\begin{matrix} +.0005 \\ -.0000 \end{matrix}$ ◎ .0005 P to D

Shape P, W $\pm .0005$ ◎ .001 P, W to D

Back Draft .001/inch L2 max.

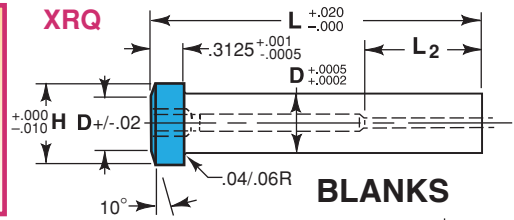

Ordering Example:

Qty	Type	D	L ₂ L	P
8	XRC	100	1.00/3.00	P .662

Ordering Example:

Qty	Type	D	L ₂ L
12	XRQ	62	1.00/3.00

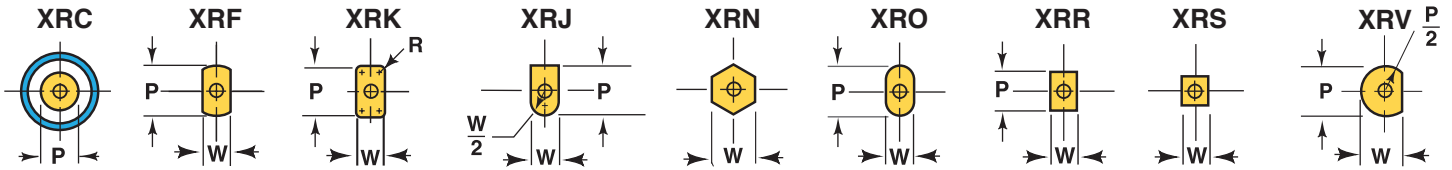
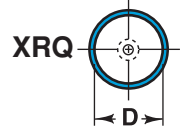

For additional standard forms and configurations see pages 30 - 33.

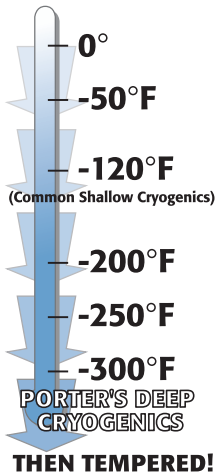

All Porter Extreme Punches are "Deep Cryogenically" treated for

1. Wear
2. Toughness
3. Dimensional Stability

See page 41 for more details.

Reflected View

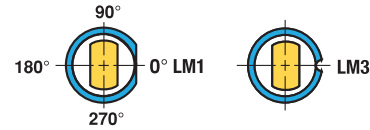

Optional Locating Methods See Page 38 & 39 for details and options.

Shank		Head H	Point Length L ₂ Alternates			Lengths L in .25" Increments	Point			Replacement Retrako Kit*
D	Code No.		(.50)	(75)	(1.00)		Round	Shape		
							Range P	Min W	Max P/G	
.3750	37	.562	●	●	●	.158 -.3749	.158	.3750	K6I	
.4375	43	.625	●	●	●	.187 -.4374	.187	.4375	K6I	
.5000	50	.687	●	●	●	.250 -.4999	.187	.5000	K6I	
.6250	62	.812	●	●	●	.375 -.6249	.250	.6250	K9I	
.7500	75	.937	●	●	●	.500 -.7499	.312	.7500	K9I	
.8750	87	1.062	●	●	●	.562 -.8749	.312	.8750	K9I	
1.0000	100	1.187	●	●	●	.625 -.9999	.375	1.0000	K9I	

*Ejector kits available see page 35 for details.

Standard Alterations are changes that are beyond the ranges listed in the catalog that can be altered for a minimal charge. See page 36.

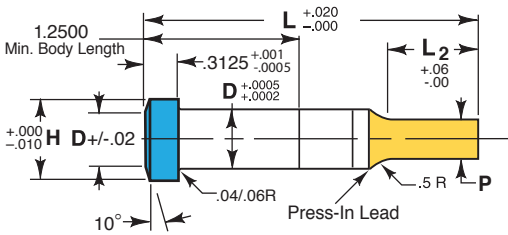

Steel: PM4 Rc 60-63
Heads Rc 40-55
TOLERANCES

Round P $\begin{matrix} +.0005 \\ -.0000 \end{matrix}$ $\text{◎} .0005$ P to D

Shape P, W $\pm .0005$ $\text{◎} .001$ P, W to D

Back Draft .001/inch L2 max.

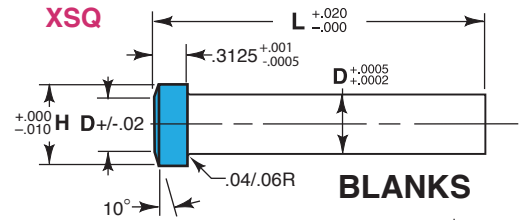

Ordering Example:

Qty	Type	D	L ₂ L	P
8	XSC	50	.50/250	P .447

Ordering Example:

Qty	Type	D	L
6	XSQ	75	x 3.00

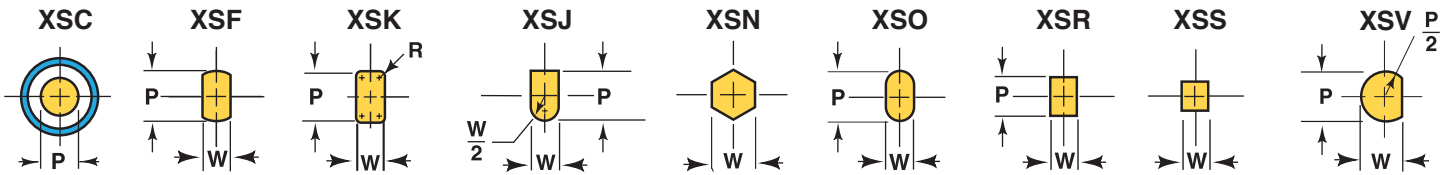
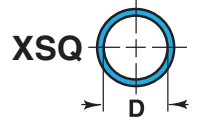

For additional standard forms and configurations see pages 30 - 33.

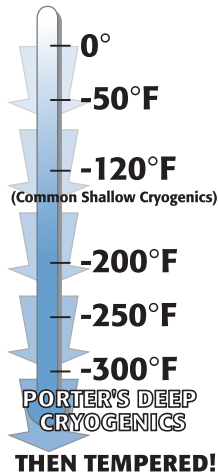

All Porter Xtreme Punches are "Deep Cryogenically" treated for

1. Wear
2. Toughness
3. Dimensional Stability

See page 41 for more details.

Reflected View



Optional Locating Methods See Page 38 & 39 for details and options.

Shank		Head H	Point Length L ₂ Alternates			Lengths L in .25" Increments	Point			
D	Code No.		(.50)	(75)	(1.00)		Round		Shape	
							Min P	Range P	Min W	Max P/G
.3750	37	.562	●	●	●	2.25 thru 5.00	.158	.158 - .3749	.158	.3750
.4375	43	.625	●	●	●	2.25 thru 5.00	.158	.187 - .4374	.187	.4375
.5000	50	.687	●	●	●	2.25 thru 5.00	.158	.250 - .4999	.187	.5000
.6250	62	.812	●	●	●	2.50 thru 5.00	.235	.375 - .6249	.250	.6250
.7500	75	.937	●	●	●	2.50 thru 5.00	.300	.500 - .7499	.312	.7500
.8750	87	1.062	●	●	●	2.50 thru 5.00	.400	.562 - .8749	.312	.8750
1.0000	100	1.187	●	●	●	2.50 thru 5.00	.400	.625 - .9999	.375	1.0000

Standard Alterations are changes that are beyond the ranges listed in the catalog that can be altered for a minimal charge. See page 36.

Regular Parabolic Pilot-SP Type

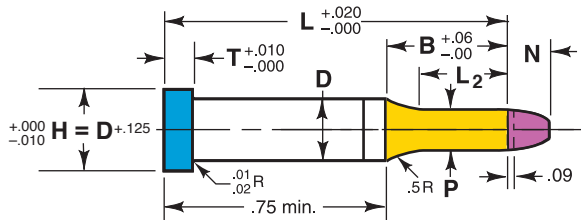

B & L Lengths do not include Pilot Tip N

Ordering Example: Qty Steel Type D B L P
6 D2 SP 62 S x 3.00 P.500

Steel: D2 Rc 58-61
M2 Rc 60-63
Heads Rc 40-55 (1" Ø and smaller and L > 2")

TOLERANCES

Round P $^{+.0005}_{-.0000}$ © .0005 P to D

Headless Punch Pilots are also available.
To order call out: **Regular Pilot = HSP**
Angular Pilot = HAP

Pilot Type	D $^{+.0005}_{+.0002}$	Point Length B				Lengths L in .25" Increments	Range P $^{+.0005}_{-.0000}$	N	T
		Std.	Alternates						
		S	B(.75)	C(1.0)	D(1.25)				
SP18	.1875	.437	●			1.50 thru 3.75	.061 - .1875	.250	.125
SP25	.2500	.500	●			1.50 thru 4.00	.061 - .2500	.250	.125
SP31	.3125	.562	●	●		1.50 thru 4.00	.092 - .3125	.250	.125
SP37	.3750	.625	●	●		1.75 thru 4.50	.124 - .3750	.250	.187
SP43	.4375	.750	●	●	●	1.50 thru 4.00	.186 - .4375	.250	.188
SP50	.5000	.812	●	●	●	2.00 thru 4.50	.249 - .5000	.250	.187
SP62	.6250	.937	●	●	●	2.00 thru 4.50	.374 - .6250	.250	.250
SP75	.7500	1.062	●	●	●	2.25 thru 4.50	.499 - .7500	.250	.250
SP87	.8750	1.125	●	●	●	2.50 thru 4.00	.561 - .8750	.250	.250
SP100	1.0000	1.250	●	●	●	2.50 thru 4.50	.624 - 1.0000	.250	.250
SP125	1.2500	1.375		●	●	2.50 thru 4.50	.624 - 1.2500	.250	.250

D2 up to 1.00 Ø 4.00 (OAL)

All Lengths under 4.50 L+N in Light Blue Panel have Hot Forged Heads for added strength and toughness.

Angular Pilot-SAP Type

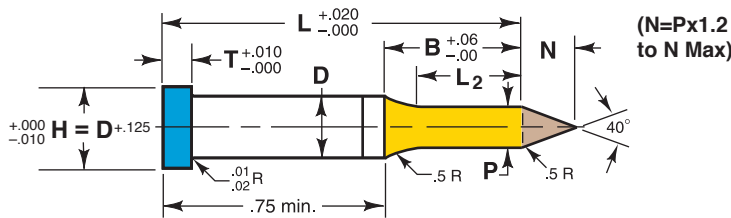

B & L Lengths do not include Pilot Tip N

Ordering Example: Qty Steel Type D B L P
4 M2 SAP 50 C x 3.00 P.436

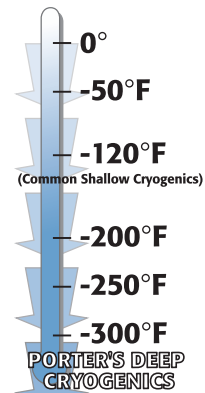

All Standard Punches up to 25mm Dia. are "Deep Cryogenically" treated for:
1. Wear
2. Toughness
3. Dimensional Stability

See page 41 for more details.

THEN TEMPERED!

Pilot Type	D $^{+.0005}_{+.0002}$	Point Length B				Lengths L in .25" Increments	Range P $^{+.0005}_{-.0000}$	N MAX	T
		Std.	Alternates						
		S	B(.75)	C(1.0)	D(1.25)				
SAP18	.1875	.437	●			2.25 thru 3.50	.061 - .1875	.187	.125
SAP25	.2500	.500	●			2.25 thru 3.50	.061 - .2500	.250	.125
SAP31	.3125	.562	●	●		2.50 thru 4.00	.092 - .3125	.312	.125
SAP37	.3750	.625	●	●		2.50 thru 4.25	.124 - .3750	.375	.187
SAP43	.4375	.750		●	●	2.25 thru 4.25	.186 - .4375	.437	.188
SAP50	.5000	.812	●	●	●	2.50 thru 5.50	.249 - .5000	.500	.187
SAP62	.6250	.937	●	●	●	2.50 thru 5.25	.374 - .6250	.625	.250
SAP75	.7500	1.062	●	●	●	2.50 thru 5.25	.436 - .7500	.750	.250
SAP87	.8750	1.125	●	●	●	3.00 thru 5.00	.561 - .8750	.875	.250
SAP100	1.0000	1.250	●	●	●	3.00 thru 5.00	.624 - 1.0000	1.000	.250
SAP125	1.2500	1.375		●	●	3.00 thru 3.75	.624 - 1.2500	1.250	.250

D2 up to 1.00 Ø 4.00 (OAL)

All Lengths under 4.50 L+N in Light Blue Panel have Hot Forged Heads for added strength and toughness.

Standard Alterations are changes that are beyond the ranges listed in the catalog that can be altered for a minimal charge. See page 36.

PORTER® Sur-Align Pilots

Sur-Align Straight (SAPQ)

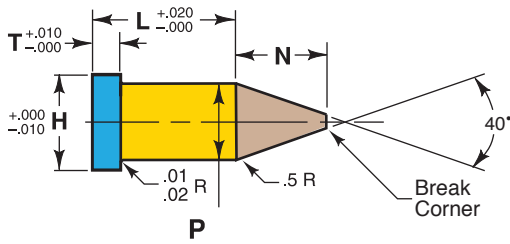

Steel: D2 Rc 58-61,
M2 Rc 60-63

© .0005 P to D

Sur-Align Nibbed (SAPN)

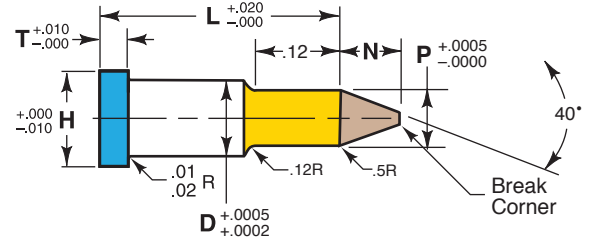

Ordering Example: Qty Steel Type D L P Dim. Alt.
10 M2 SAPQ 0.87 P 0.270 RL.725

Ordering Example: Qty Steel Type D L P Dim. Alt.
20 M2 SAPN 75 1.37 P 0.630

Type	Range P	Max N	Head		Lengths L							Shank			Min P	Range P	Max N
			T	H	0.625	0.750	0.875	1.000	1.125	1.250	1.375	Type	D	Code			
SAPQ	.1865-.2500	.25	.125	.375	●	●	●	●	●	●	●	SAPN 25	.2500	25	.092	.1650-.2499	.25
SAPQ	.2501-.3125	.31	.125	.438	●	●	●	●	●	●	●	SAPN 31	.3125	31	.092	.2100-.3124	.31
SAPQ	.3126-.3750	.37	.188	.500	●	●	●	●	●	●	●	SAPN 37	.3750	37	.092	.2550-.3749	.37
SAPQ	.3751-.4375	.43	.188	.562	●	●	●	●	●	●	●	SAPN 43	.4375	43	.092	.3000-.4374	.43
SAPQ	.4376-.5000	.50	.188	.625	●	●	●	●	●	●	●	SAPN 50	.5000	50	.124	.3450-.4999	.50
SAPQ	.5001-.6250	.62	.250	.750	●	●	●	●	●	●	●	SAPN 62	.6250	62	.234	.4400-.6249	.62
SAPQ	.6251-.7500	.75	.250	.875	●	●	●	●	●	●	●	SAPN 75	.7500	75	.299	.5300-.7499	.75
SAPQ	.7501-.8750	.87	.250	1.000	●	●	●	●	●	●	●	SAPN 87	.8750	87	.349	.6200-.8749	.87
SAPQ	.8751-1.000	1.00	.250	1.125	●	●	●	●	●	●	●	SAPN 100	1.0000	100	.399	.7100-.9999	1.00

Any overall length within catalog range no extra cost Specify "RL" plus length.

N=P x 1.2 to N Max

PORTER® Ultra Precision Sur-Align Pilots (PAP-)

Sur-Align Straight (PAPQ)

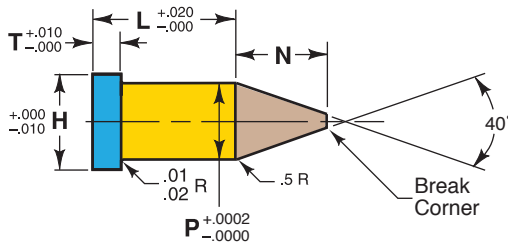

Steel: D2 Rc 58-61,
M2 Rc 60-63
PM4 Rc 63-65

© .0003 P to D

Sur-Align Nibbed (PAPN)

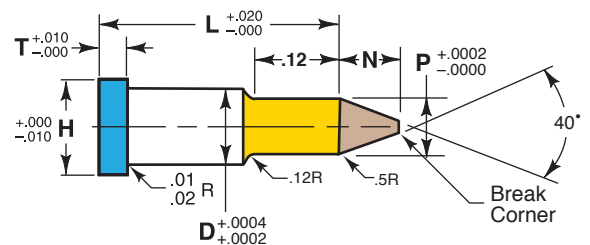

Ordering Example: Qty Steel Type L P Dim. Alt.
10 M2 PAPQ 0.87 P.270 RL.725

Ordering Example: Qty Steel Type D L P Dim. Alt.
20 PM4 PAPN 75 1.37 P .630

Type	Range P	Max N	Head		Lengths L							Shank			Min P	Range P	Max N
			T	H	0.625	0.750	0.875	1.000	1.125	1.250	1.375	Type	D	Code			
PAPQ	.1865-.2500	.25	.188	.375	●	●	●	●	●	●	●	PAPN 25	.2500	25	.092	.1650-.2499	.25
PAPQ	.2501-.3130	.31	.188	.438	●	●	●	●	●	●	●	PAPN 31	.3125	31	.092	.2100-.3124	.31
PAPQ	.3131-.3750	.37	.188	.500	●	●	●	●	●	●	●	PAPN 37	.3750	37	.092	.2550-.3749	.37
PAPQ	.3751-.4380	.43	.188	.562	●	●	●	●	●	●	●	PAPN 43	.4375	43	.092	.3000-.4374	.43
PAPQ	.4381-.5000	.50	.188	.625	●	●	●	●	●	●	●	PAPN 50	.5000	50	.124	.3450-.4999	.50
PAPQ	.5001-.6250	.62	.188	.750	●	●	●	●	●	●	●	PAPN 62	.6250	62	.234	.4400-.6249	.62
PAPQ	.6251-.7500	.75	.188	.875	●	●	●	●	●	●	●	PAPN 75	.7500	75	.299	.5300-.7499	.75
PAPQ	.7501-.8750	.87	.188	1.000	●	●	●	●	●	●	●	PAPN 87	.8750	87	.349	.6200-.8749	.87
PAPQ	.8751-1.000	1.00	.188	1.125	●	●	●	●	●	●	●	PAPN 100	1.0000	100	.399	.7100-.9999	1.00

Any overall length within catalog range no extra cost Specify "RL" plus length.

N=P x 1.2 to N Max

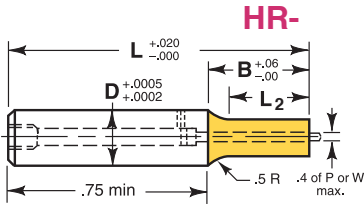

HR-

Steel: M2 Rc 60-63

TOLERANCES

Round P $\begin{matrix} +.0005 \\ -.0000 \end{matrix}$ ◎ .0005 P to D

Shape P, W $\pm .0005$ ◎ .001 P,W to D

Back Draft .001/inch L2 max.

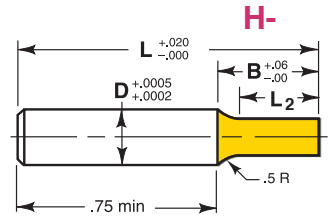

H-

Ordering Example:

Qty Steel Type D B L P
13 M2 HRC 37 C x 3.00 P .250

Ordering Example:

Qty Steel Type D B L P
13 M2 HC 25 B x 2.00 P .187

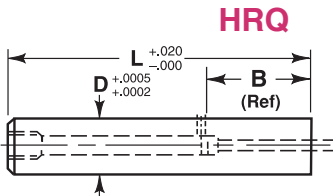

HRQ

**D = $-.0002$
add AD to callout**

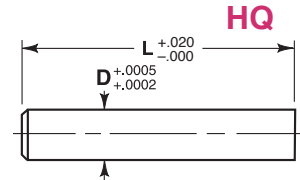

HQ

Ordering Example: BLANKS

Qty Steel Type D B L
13 M2 HRQ 50 C x 2.50

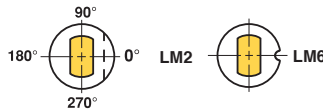

Optional Locating Methods See page 38 & 39 for details and options.

Ordering Example: BLANKS

Qty Steel Type D L
13 M2 HQ 62 x 3.00

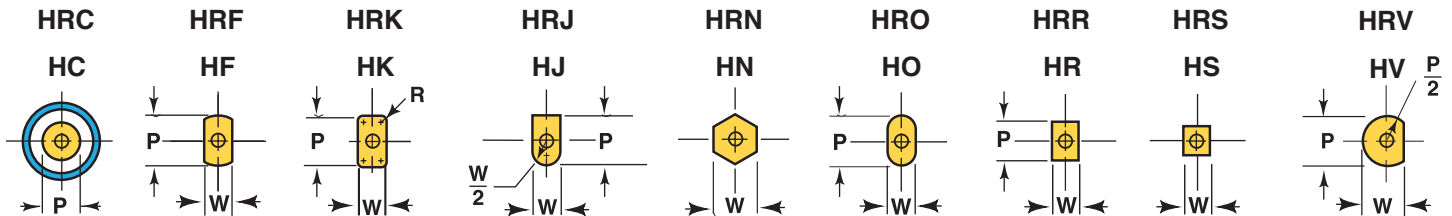

For additional standard forms and configurations see pages 30 - 33.

Shank		Point Length B				Lengths L in .25" Increments	Point			Replacement Retracto Kit*
D	Code No.	Standard	Alternates				Round	Shape		
		S	B(.75)	C(1.0)	D(1.25)		E(1.5)	Range P	Min W	
.1875	18	.437	●			1.50 thru 3.00	.062 - .1874	.062	.1875	K2I
.2500	25	.500	●			1.50 thru 3.00	.093 - .2499	.093	.2500	K3I
.3125	31	.562	●	●		1.50 thru 3.00	.125 - .3124	.125	.3125	K4I
.3750	37	.625	●	●		1.75 thru 4.00	.187 - .3749	.187	.3750	K6I
.4375	43	.750	●	●		2.00 thru 4.00	.187 - .4374	.187	.4375	K6I
.5000	50	.812	●	●	●	2.00 thru 5.00	.250 - .4999	.187	.5000	K6I
.6250	62	.937	●	●	●	2.00 thru 4.25	.375 - .6249	.250	.6250	K9I
.7500	75	1.062	●	●	●	2.25 thru 4.25	.500 - .7499	.312	.7500	K9I
.8750	87	1.125	●	●	●	2.50 thru 4.00	.594 - .8749	.375	.8750	K9I
1.0000	100	1.250	●	●	●	2.50 thru 4.00	.687 - .9999	.375	1.0000	K9I

*Retracto Kits available see page 35 for details.

Standard Alterations are changes that are beyond the ranges listed in the catalog that can be altered for a minimal charge. See page 36.

STD LM-7	
D	A°
.25 .31 .37	5°
.50	7.5°
.62 - 2.50	10°

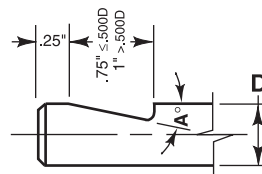

For Shape and Form Headless Punches Specify LM7 relation to shape Standard location is at 0° Alternate angles are available Specify LM7 A=12°

PORTER® Standard Die Button

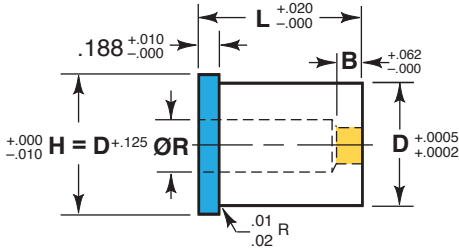

Steel: M2 Rc 60-63

TOLERANCES

Round P $\begin{matrix} +.0005 \\ -.0000 \end{matrix}$ $\text{Ⓞ} \begin{matrix} .0005 \\ P \text{ to } D \end{matrix}$

Shape P, W $\begin{matrix} +.001 \\ -.000 \end{matrix}$ $\text{Ⓞ} \begin{matrix} .001 \\ P, W \text{ to } D \end{matrix}$

① D Tol = $\begin{matrix} +.0006 \\ +.0002 \end{matrix}$

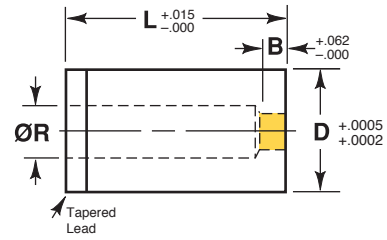

Ordering Example:

Qty Steel Type D L P
4 M2 HNDC 75 x 1.25 P.390

Ordering Example:

Qty Steel Type D L P W Locate
6 M2 NDO 100 x 1.25 P.605 W.305 LM1

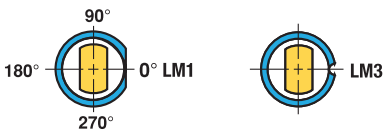

Optional Locating Methods See Page 38 & 39 for details and options.

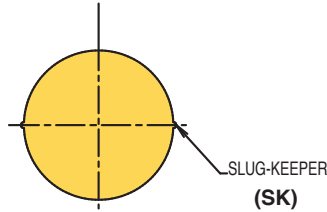

Porter's Slug keeper can be added to any round or shape die to reduce slug pulling



Optional Locating Methods See Page 38 & 39 for details and options.

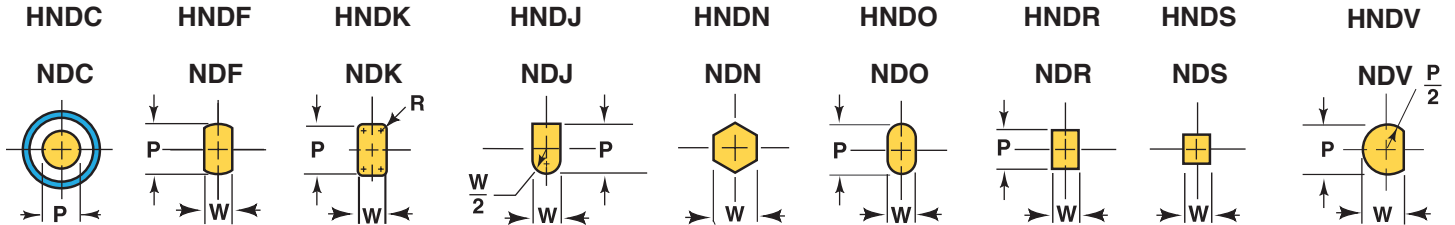

For additional standard forms and configurations see pages 30 - 33.

Body D**	Code No.	Min. B*	Max. R	Lengths L (ND) Headless & (HND-) Headed									Round ID		Shape ID	
				.75	.87	.93	1.00	1.125	1.188	1.250	1.375	1.500	Range P	Min. W	Max. P/G	
.2500	25	.156	.156	●	●	N	●	●	N	●			.064 - .125	-	-	
.3125	31	.156	.195	N	N	N	N	N	N	N			.064 - .155	-	-	
.3750	37	.156	.228	●	●	N	●	●	N	●	N	●	.064 - .195	.048	.195	
.5000	50	.156	.312	●	●	N	●	●	N	●	N	●	.064 - .285	.064	.285	
.6250	62	.187	.391	●	●	N	●	●	N	●	N	●	.136 - .365	.095	.365	
.7500	75	.187	.468	●	●	N	●	●	N	●	N	●	.136 - .435	.135	.435	
.8750	87	.187	.578	●	●	N	●	●	N	●	N	●	.276 - .545	.135	.545	
1.0000	100	.250	.703	●	●	N	●	●	N	●	N	●	.356 - .675	.135	.675	
1.2500	125	.250	.828	●	●	N	●	●	N	●	N	●	.500 - .800	.189	.800	
1.5000	150	.250	1.094	●	●	N	●	●	N	●	N	●	.616 - 1.050	.252	1.050	

* Alternate "B" lengths available see page 15 (Taper Relief Dies). N = ND only.

Standard Alterations are changes that are beyond the ranges listed in the catalog that can be altered for a minimal charge. See page 36.

PORTER® Bal-Lok Die Buttons (BD-)

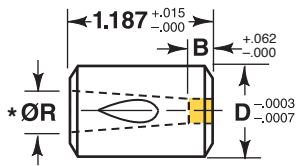

Ordering Example:

Qty Type Body P W
6 BDR 75 P.280 W.156

Steel: M2 Rc 60-63

TOLERANCES

Round P $^{+.0005}$ _{-.0000} ◎ .0005 P to D
Shape P, W $^{+.001}$ _{-.000} ◎ .001 P,W to D
1 Degree taper per side relief

BDW
Wire EDM
Blank



Ordering Example:
Qty Steel Type Body
6 M2 BDW 75

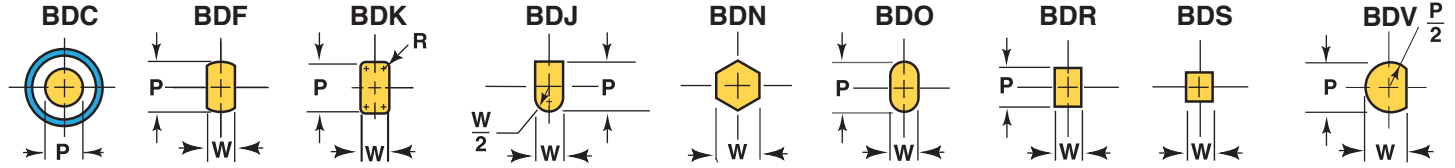

Body Code	D	Min. B	Max. R	Length L	Round I.D.		Shape I.D.		BDW Hole Size
					Range P	Min. W	Max. P/G		
50	.500	.156	.250	1.187	.064 - .220	.048	.220	.043 or .093	
62	.625	.187	.313	1.187	.110 - .282	.064	.282	.043 or .093	
75	.750	.187	.422	1.187	.125 - .391	.095	.391	.043 or .125	
87	.875	.187	.547	1.187	.196 - .516	.135	.516	.125	
100	1.000	.250	.688	1.187	.346 - .657	.158	.657	.125	
125	1.250	.250	.844	1.187	.436 - .813	.189	.813	.125	
150	1.500	.250	1.094	1.187	.545 - 1.063	.220	1.063	.125	
175	1.750	.312	1.297	1.187	.656 - 1.262	.252	1.262	.125	

*SPECIAL NOTE: Large quantities of Bal-Lok die buttons may be substituted with a stepped relief.

For additional standard forms and configurations see pages 30 - 33.

Standard Ball Seat location is at 90°, alternate locations of 0°, 180° and 270° are available at no extra charge.

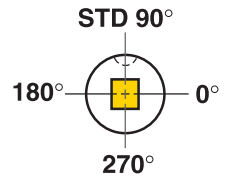

Supplied with 1% / side taper Alter Taper (AT=)

PORTER® Steel Guide Bushings

GL-HEADLESS

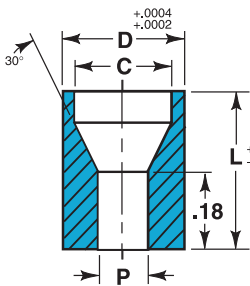

GD-HEAD-DOWN

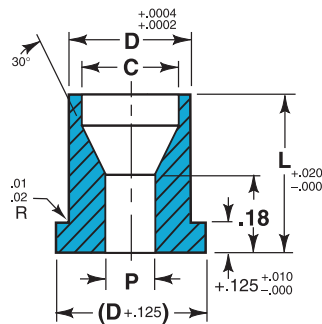

GU-HEAD-UP

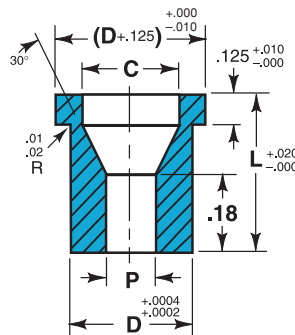

Steel: D2 Rc 58-61
TOLERANCES
P & W $^{+.0005}$ _{-.0000} ◎ .0003 P to D

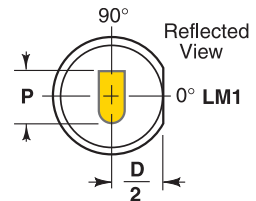

Ordering Example:

Headless 4 ea. GLC 50 x .62 P .298
Head-Down 4 ea. GDO 62 x .50 P .327 W .187 LM1
Head-Up 4 ea. GUS 50 x .50 P .250 LM2

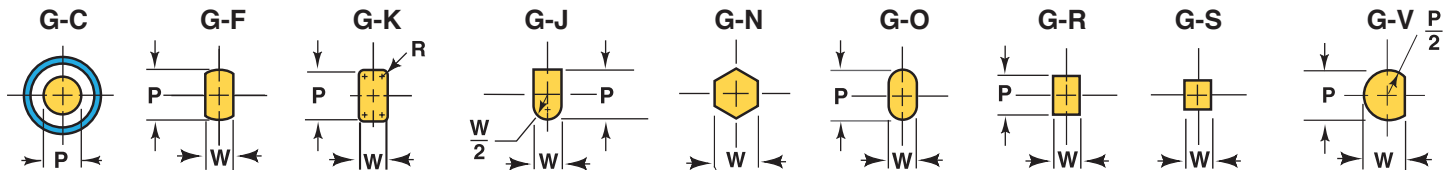

Body ØD	Code No.	Length L			Circular ID		Shape ID		Ø C	Match Punch Shank Ø
		.37	.50	.62	Range P	Min. W	Max. P/G			
.2500	25	●	●	●	.062 - .125	.062	.125	.140	.125	
.3125	31	●	●	●	.062 - .188	.062	.188	.202	.187	
.3750	37	●	●	●	.062 - .250	.062	.250	.265	.250	
.4375	43	●	●	●	.093 - .313	.093	.313	.327	.312	
.5000	50	●	●	●	.125 - .375	.125	.375	.390	.375	
.6250	62	●	●	●	.187 - .438	.187	.438	.452	.437	
.7500	75	●	●	●	.187 - .500	.187	.500	.515	.500	
.8750	87	●	●	●	.310 - .625	.250	.625	.640	.625	
1.0000	100	●	●	●	.390 - .750	.312	.750	.765	.750	

Locating flats and dowels, see page 38 & 39.

- Guide Bushing I.D. should be at least .0005 larger than the punch point that it is used with.

Head Type Perforators (B)

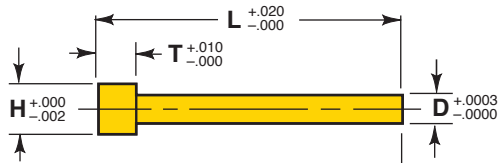

Head Type Perforators (AB)

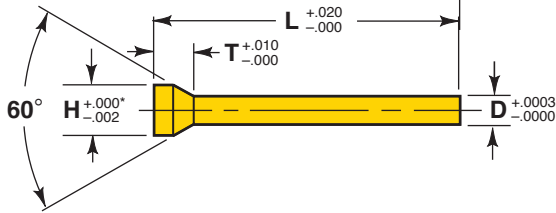

Head Type Perforators (A)

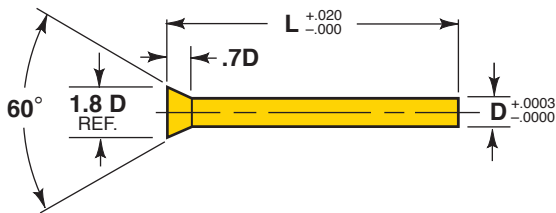

Steel: M2 Rc 60-63
Heads Rc 40-55 (L > 2)
TOLERANCES

P $\begin{matrix} +.0005 \\ -.0000 \end{matrix}$ $\text{\textcircled{.0003}}$ P to D

D Range .031-.250

Pointed Perforators NB

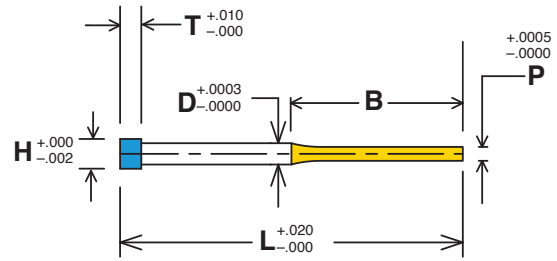

Pointed Perforators NAB

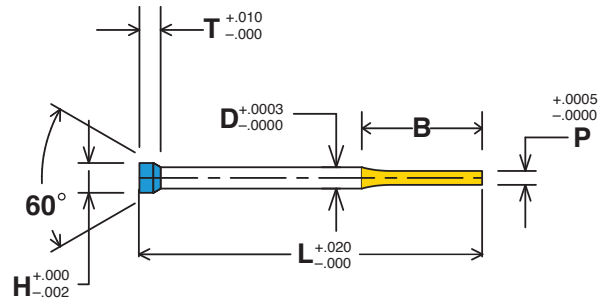

Pointed Perforators NA

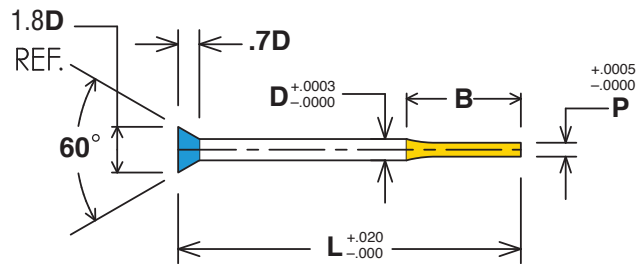

Ordering Example:

Qty.	Style	D	L	H	T
12	B	.093 x 2.00		H=.140	T=.125

Ordering Example:

Qty.	Style	D	L	H	T	P	B
12	NA	.156 x 2.00				P=.125	B=.500
12	NB	.156 x 2.00		H=.219	T=.188	P=.125	B=.500

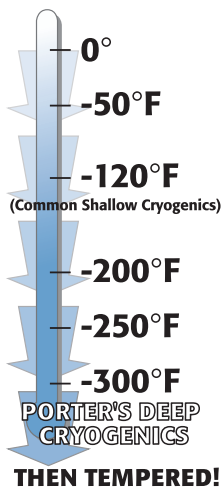

All Perforators are "Deep Cryogenically" treated for
1. Wear
2. Toughness
3. Dimensional Stability

See page 41 for more details.

Pilot Tips (P)

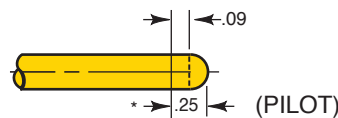

Ordering Example:

Qty.	Style	D	L	H	T	P	B
6	PB	.156 x 2.50		H=2.50	T=.188		
6	PNB	.156 x 2.50		H=2.50	T=.188	P=.093	B=.500

*Adds .250 max to (L) on all perforators
Angle Pilots (AP)

PORTER® CQ Perforator Holders

Style B Head

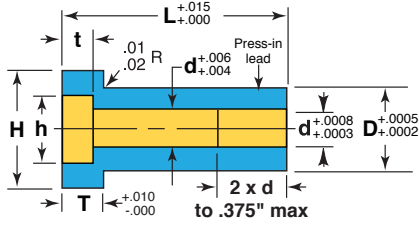

Style AB Head

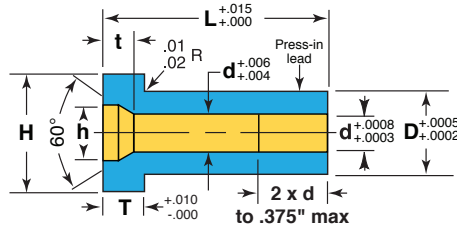

Style A Head

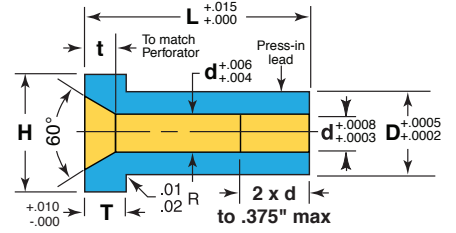

Catalog No.	D	Lengths L in .25" Increments	d 0.01 Increment	h	t
CQ-18	.1875	.75 - 1.25	.040 - .060	Punch head diameter +.015	Head thickness Diameter +.0000-.010
CQ-25	.2500	.75 - 1.50	.060 - .126		
CQ-31	.3125	.75 - 2.00	.080 - .160		
CQ-37	.3750	1.00 - 2.25	.161 - .218		
CQ-43	.4375	1.00 - 2.25	.200 - .250		

Customer must supply perforator dimensions with order

Ordering Example:

Qty. Cat. No. x L x d Style
12 CQ-37 x1.00 d =.187 AB

Steel: D2, Rc 58-61

TOLERANCES

.0003 ©

PORTER® Support Quill Series

BQH

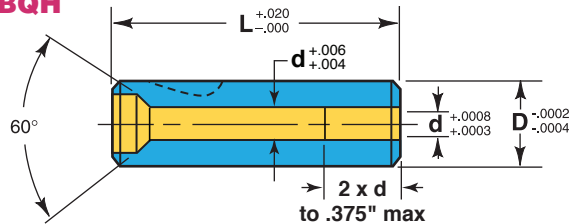

Ordering Example:

Qty. Cat. No. x L Head Style
3 BQH-37 x1.25 AB

Catalog No.	D	Length L	d	h	t
BHQ-37	37	Perforator (L) - .250	Perforator (D)	Perforator (H)	Perforator (T)
BHQ-50	50				
BHQ-62	62				
BHQ-75	75				
BHQ-100	100				
BHQ-125	125				

Customer must supply perforator dimensions with order



HEAD TYPE PUNCH RETAINERS

INCH - Round



Retainer Set Includes:

- 2 Screws
- 2 Dowels

Material:
Retainer: SAE 4140/43-48 HRc.

Catalog #:
IRR.xxx

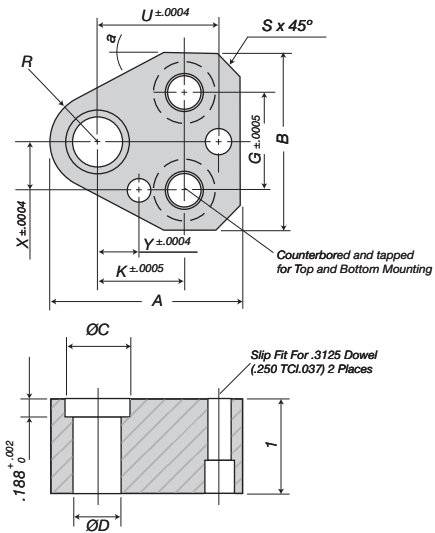

INCH

Catalog #	ØD	A	B	C	G	K	R	S	U	X	Y	a°	Screw Size	Tapered Hole
IRR037	0.375	1.744	1.614	0.540	0.876	0.750	0.37	0.197	1.060	0.354	0.295	30°	5/16-18	3/8-16
IRR050	0.500	1.984	1.850	0.660	1.124	0.750	0.49	0.295	1.180	0.472	0.256	28°	5/16-18	3/8-16
IRR062	0.625	2.106	1.969	0.780	1.250	0.750	0.55	0.335	1.250	0.532	0.236	28°	5/16-18	3/8-16
IRR075	0.750	2.366	2.165	0.900	1.376	0.750	0.69	0.394	1.320	0.650	0.197	28°	5/16-18	3/8-16
IRR100	1.000	2.744	2.480	1.160	1.562	0.938	0.87	0.472	1.600	0.866	0.276	28°	1/2-13	5/8-11
IRR125	1.250	2.744	2.480	1.420	1.562	0.938	0.87	0.472	1.600	0.866	0.276	28°	1/2-13	5/8-11

INCH - Shaped



Retainer Set Includes:

- 2 Screws
- 2 Dowels

Material:
Retainer: SAE 4140/43-48 HRc.

Catalog #:
ISR.xxx

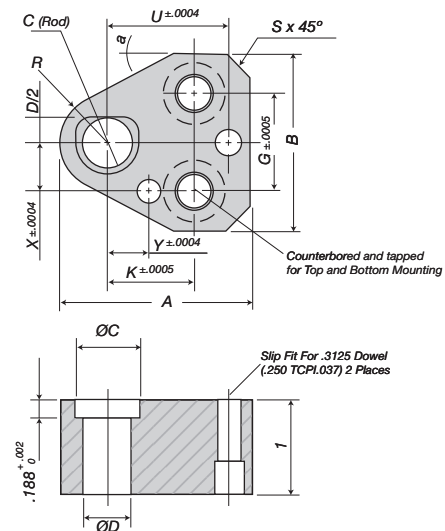

INCH

Catalog #	ØD	A	B	C	G	K	R	S	U	X	Y	a°	Screw Size	Tapered Hole
ISR037	0.375	1.744	1.614	0.270	0.876	0.750	0.37	0.197	1.060	0.354	0.295	30°	5/16-18	3/8-16
ISR050	0.500	1.984	1.850	0.330	1.124	0.750	0.49	0.295	1.180	0.472	0.256	28°	5/16-18	3/8-16
ISR062	0.625	2.106	1.969	0.390	1.250	0.750	0.55	0.335	1.250	0.532	0.236	28°	5/16-18	3/8-16
ISR075	0.750	2.366	2.165	0.450	1.376	0.750	0.69	0.394	1.320	0.650	0.197	28°	5/16-18	3/8-16
ISR100	1.000	2.744	2.480	0.580	1.562	0.938	0.87	0.472	1.600	0.866	0.276	28°	1/2-13	5/8-11
ISR125	1.250	2.744	2.480	0.710	1.562	0.938	0.87	0.472	1.600	0.866	0.276	28°	1/2-13	5/8-11



STANDARD BALL LOCK PUNCH RETAINERS

CAD DATA AVAILABLE UPON REQUEST

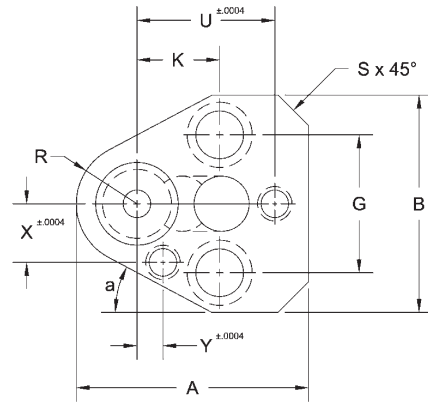

Retainer Set Includes:

- 1 Ball
- 1 Spring
- 2 Screws
- 2 Dowels
- 1 Ball Release
- 1 Set Screw

Material:

Retainer: SAE 4140/43-48 HRc.
Backing Plug: SAE S1 / 50 - 54 HRc.

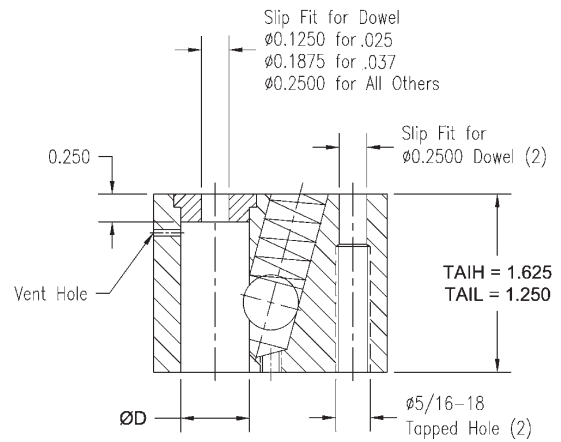

Catalog Number	ØD	A	B	U	Y	K	G	X	R	S	a°	Screw Size
LIGHT DUTY												
ILR 025	0.250	1.744	1.614	1.060	0.295	0.750	0.876	0.354	0.37	0.197	30°	5/16-18
ILR 037	0.375	1.744	1.614	1.060	0.295	0.750	0.876	0.354	0.37	0.197	30°	5/16-18
ILR 050	0.500	1.984	1.850	1.180	0.256	0.750	1.124	0.472	0.49	0.256	28°	3/8-16
ILR 062	0.625	2.106	1.969	1.250	0.236	0.750	1.250	0.532	0.55	0.276	28°	3/8-16
ILR 075	0.750	2.366	2.165	1.320	0.197	0.750	1.376	0.650	0.69	0.315	28°	3/8-16
ILR 087	0.875	2.492	2.291	1.400	0.197	0.750	1.376	0.728	0.75	0.433	28°	3/8-16
ILR 100	1.000	2.744	2.480	1.600	0.276	0.938	1.562	0.866	0.87	0.354	28°	1/2-13
HEAVY DUTY												
IHR 037	0.375	1.744	1.614	1.060	0.295	0.750	0.876	0.354	0.37	0.197	30°	5/16-18
IHR 050	0.500	1.984	1.850	1.180	0.256	0.750	1.124	0.472	0.49	0.256	28°	3/8-16
IHR 062	0.625	2.106	1.969	1.250	0.236	0.750	1.250	0.532	0.55	0.276	28°	3/8-16
IHR 075	0.750	2.366	2.165	1.320	0.197	0.750	1.376	0.650	0.69	0.315	28°	3/8-16
IHR 087	0.875	2.492	2.291	1.400	0.197	0.750	1.376	0.728	0.75	0.433	28°	3/8-16
IHR 100	1.000	2.744	2.480	1.600	0.276	0.938	1.562	0.866	0.87	0.354	28°	1/2-13
IHR 125	1.250	2.744	2.480	1.600	0.276	0.938	1.562	0.866	0.87	0.354	28°	1/2-13

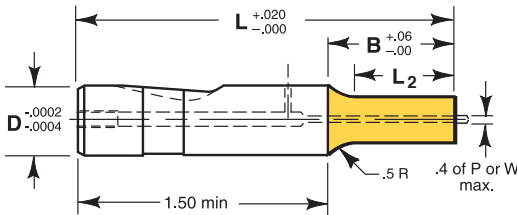

**Steel: M2 Rc 60-63
PM4 Rc 63-65 L≤4"**

TOLERANCES

Round P $\begin{matrix} +.0005 \\ -.0000 \end{matrix}$ $\text{Ⓢ} .0005$ P to D

Shape P, W $\pm .0005$ $\text{Ⓢ} .001$ P,W to D

Back Draft .001/inch L2 max.

Ordering Example:

Qty	Steel	Type	D	B	L	P	W
13	M2	HBRO	75	D	x 4.00	P.625	W.500

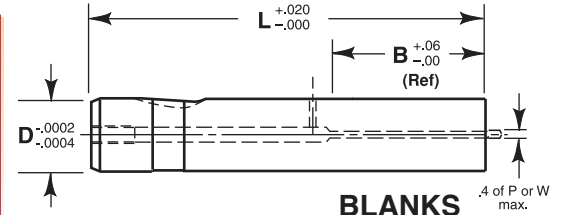

Ordering Example:

Qty	Steel	Type	D	B	L
25	PM4	HBRB	50	C	x 3.50

BLANKS

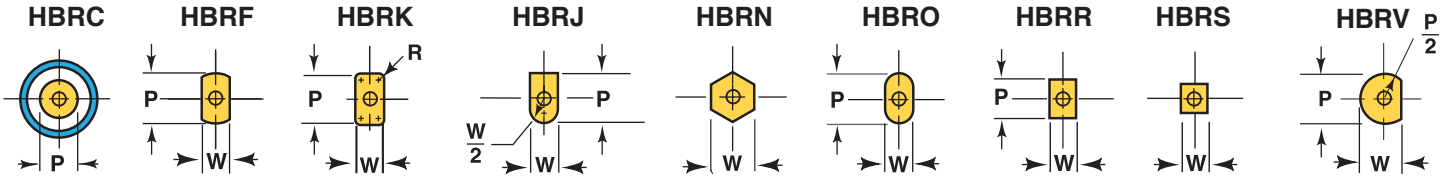
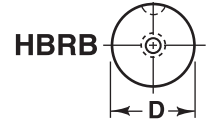

For additional standard forms and configurations see pages 30 - 33.

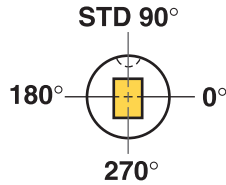

Standard ball seat location is at 90° using reflected view for punches. Alternate locations of 0°, 180° and 270° are available at no extra charge. Custom ball seat locations can be specified as number of degrees counterclockwise from 0° Example call out: BS 180°

Shank		Point Length B				Lengths L in .25" Increments	Point			Replacement Retracto Kit*
D	Code No.	Standard S	Alternates				Round Range P	Shape Min W Max P/G		
.375	37	.625	•	•		2.50 thru 4.25	.062 -.374	.125	.374	K2I K4I
.500	50	.812	•	•	•	2.50 thru 5.00	.180 -.499	.187	.499	K6I
.625	62	.937	•	•	•	2.50 thru 5.00	.312 -.624	.250	.624	K6I
.750	75	1.062	•	•	•	2.50 thru 5.00	.437 -.749	.312	.749	K9I
.875	87	1.187	•	•	•	2.75 thru 5.00	.620 -.874	.375	.874	K9I
1.000	100	1.250	•	•	•	3.00 thru 5.00	.750 -.999	.437	.999	K9I
1.250	125	1.437	•	•	•	3.00 thru 5.00	1.000-1.249	.500	1.249	K12I

*Ejector Kits available see page 35 for details. Retracto Punches 1.25 Ø = no side hole. PM4 and Punches > 4" = no side hole.

Standard Alterations are changes that are beyond the ranges listed in the catalog that can be altered for a minimal charge. See page 36.

PORTER® Heavy Duty Bal-Lok Solid Punch (HB-)

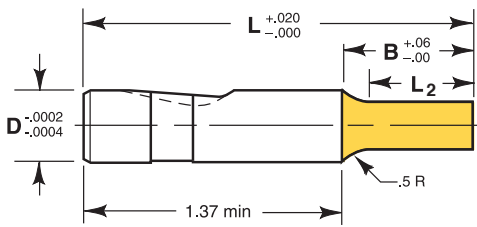

**Steel: M2 Rc 60-63
PM4, Rc 63-65 L ≤ 4"**

TOLERANCES

Round P $\begin{matrix} +.0005 \\ -.0000 \end{matrix}$ ◎ .0005 P to D

Shape P, W $\pm .0005$ ◎ .001 P,W to D

Back Draft .001/inch L2 max.

Ordering Example:

Qty Steel Type D B L P
10 PM4 HBC 50 B x 3.50 P.265

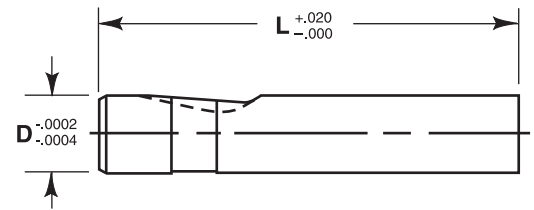

BLANKS

Ordering Example:

Qty Steel Type D L
25 M2 HBB 62 x 4.75

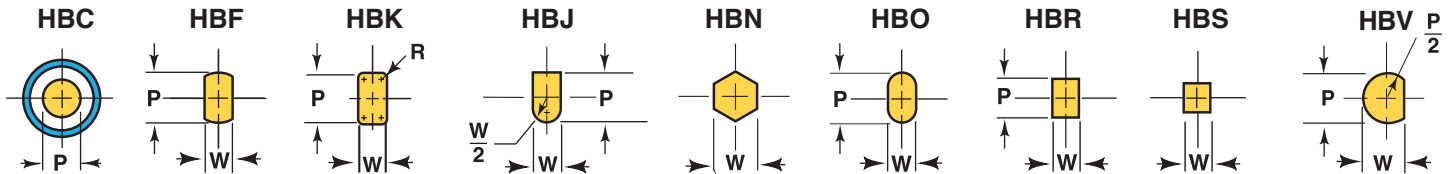
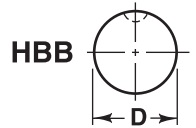

For additional standard forms and configurations see pages 30 - 33.

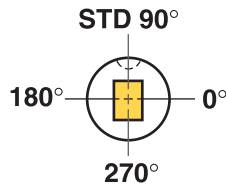

Standard ball seat location is at 90° using reflected view for punches. Alternate locations of 0°, 180° and 270° are available at no extra charge. Custom ball seat locations can be specified as number of degrees counterclockwise from 0° Example call out: BS 180°

Shank		Point Length B				Lengths L in .25" Increments	Point		
		Standard	Alternates				Round Range P	Shape	
D	Code No.	S	B(.75)	C(1.0)	D(1.25)			Min W	Max P/G
.375	37	.625	•	•		2.50 thru 5.00	.062 - .374	.062	.374
.500	50	.812	•	•	•	2.50 thru 6.00	.187 - .499	.187	.499
.625	62	.937	•	•	•	2.50 thru 6.00	.312 - .624	.250	.624
.750	75	1.062	•	•	•	2.50 thru 6.00	.437 - .749	.312	.749
.875	87	1.187	•	•	•	2.75 thru 6.00	.625 - .874	.375	.874
1.000	100	1.250	•	•	•	3.00 thru 6.00	.750 - .999	.437	.999
1.250	125	1.437	•	•	•	3.00 thru 6.00	1.000 - 1.249	.500	1.249

Standard Alterations are changes that are beyond the ranges listed in the catalog that can be altered for a minimal charge. See page 36.

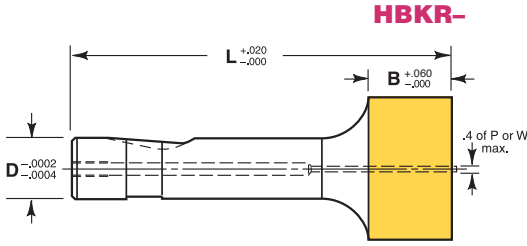

Steel: M2 Rc 60-63
TOLERANCES
 Round P $+0.0005$ -0.0000 $\text{Ⓢ} \text{ .0005}$ P to D
 Shape P, W ± 0.0005 $\text{Ⓢ} \text{ .001}$ P,W to D

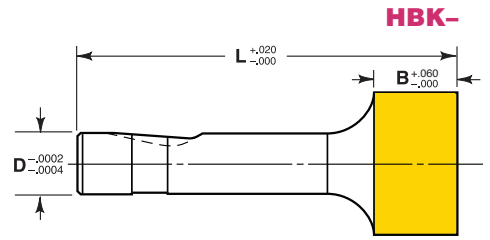

Ordering Example:

Qty Steel Type D L P W
 2 M2 HBKRO 100 x 3.00 P 1.125 W .650

Ordering Example:

Qty Steel Type D L P
 4 M2 HBKC 62 x 3.00 P 750

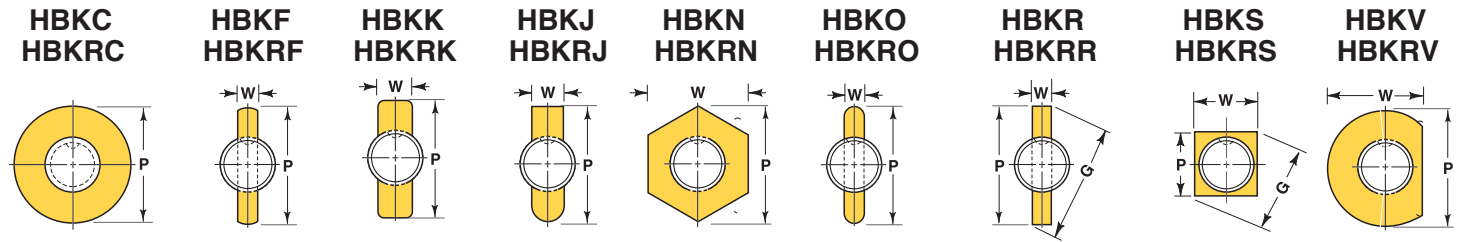

For additional standard forms and configurations see pages 30 - 33.

Shank D	Code No.	Point Length B	Lengths L in .25"							Point			Replacement Retrakto Kit*
			Increments							Round	Shape		
			3.00	3.25	3.50	3.75	4.00	Range P	Min W	Max P/G			
.375	37	.625	3.00	3.25	3.50	3.75	4.00	.376 -1.000	.125	1.000	K4I		
.500	50	.750	3.00	3.25	3.50	3.75	4.00	.501 -1.250	.188	1.250	K6I		
.625	62	.875	3.00	3.25	3.50	3.75	4.00	.626 -1.500	.250	1.500	K6		
.750	75	.937	3.00	3.25	3.50	3.75	4.00	.751 -1.500	.312	1.500	K9I		
.875	87	.937	3.00	3.25	3.50	3.75	4.00	.876 -1.750	.375	1.750	K9I		
1.000	100	.937	3.00	3.25	3.50	3.75	4.00	1.001 -1.750	.437	1.750	K9I		
1.250	125	1.250	3.00	3.25	3.50	3.75	4.00	1.251 -2.000	.500	2.000	K12I		

*Ejector kits available see page 35 for details.

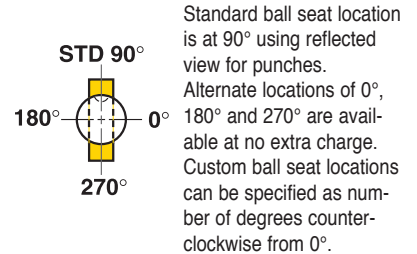

Standard Alterations are changes that are beyond the ranges listed in the catalog that can be altered for a minimal charge. See page 36.

All shank to largest point diameter will be supplied with .500 radius blend unless otherwise specified.

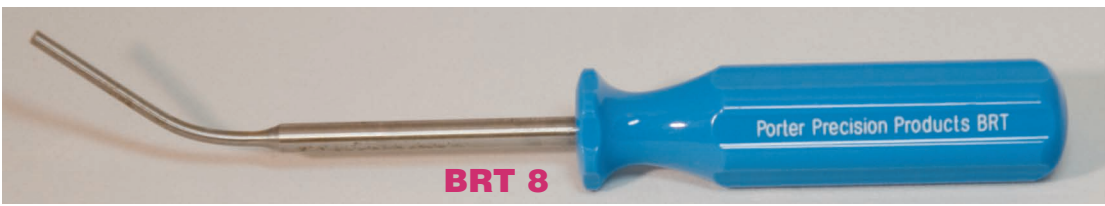

BRT 8

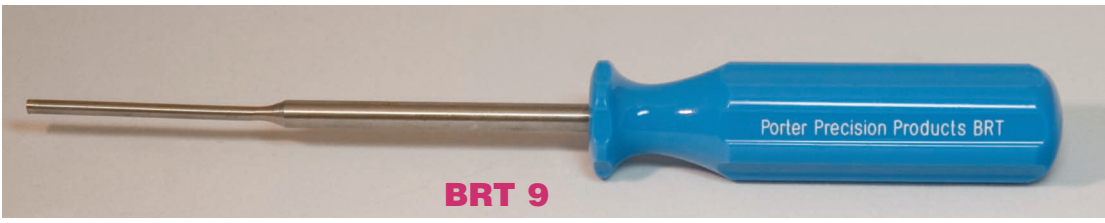

BRT 9

Regular Pilot-HBP Type

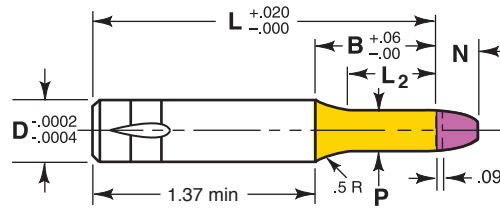

Steel: M2 Rc 60-63
 PM4 Rc 63-65 ≤ 4" (L+N)
 P Ø $\begin{matrix} +.0005 \\ -.0000 \end{matrix}$ © .0005 P to D

B & L Lengths do not include Pilot Tip N

Ordering Example:

Qty Steel Type D B L P
 8 M2 HBP 62 C x 3.00 P.500

Pilot Type	Body D Ø	Point Length B			Length L in .25" Increments	Range P	N
		Std. S	Alternates B(.75) C(1.0) D(1.25)				
HBP37	.375	.62	● ●		2.50 thru 4.75	.061 – .374	.250
HBP50	.500	.75	● ● ●		2.50 thru 5.75	.186 – .499	.250
HBP62	.625	.87	● ● ●		2.50 thru 5.75	.311 – .624	.250
HBP75	.750	.94	● ● ●		2.50 thru 5.75	.436 – .749	.250
HBP87	.875	.94	● ● ●		2.75 thru 5.75	.624 – .874	.250
HBP100	1.000	.94	● ● ●		3.00 thru 5.75	.749 – .999	.250
HBP125	1.250	1.00	● ● ●		3.00 thru 5.75	.999 – 1.249	.250

Angular Pilot-HBAP Type

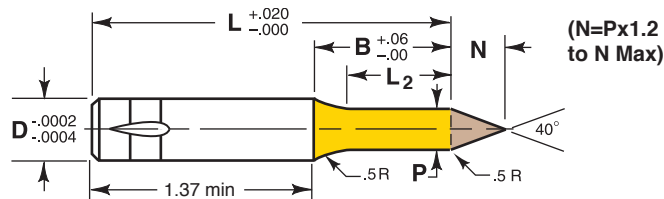

B & L Lengths do not include Pilot Tip N

Ordering Example:

Qty Steel Type D B L P
 9 M2 HBAP 62 C x 3.00 P.575

Pilot Type	Body D Ø	Point Length B			Length L in .25" Increments	Range P	N MAX
		Std. S	Alternates B(.75) C(1.0) D(1.25)				
HBAP37	.375	.62	● ●		2.50 thru 4.50	.186 – .374	.375
HBAP50	.500	.81	● ● ●		2.50 thru 5.50	.249 – .499	.500
HBAP62	.625	.94	● ● ●		2.50 thru 5.25	.311 – .624	.625
HBAP75	.750	1.06	● ● ●		2.50 thru 5.25	.436 – .749	.750
HBAP87	.875	1.19	● ● ●		2.75 thru 5.00	.624 – .874	.875
HBAP100	1.000	1.25	● ● ●		3.00 thru 5.00	.749 – .999	1.000
HBAP125	1.250	1.44	● ● ●		3.00 thru 4.75	1.000 – 1.249	1.250

Standard Alterations are changes that are beyond the ranges listed in the catalog that can be altered for a minimal charge. See page 36.

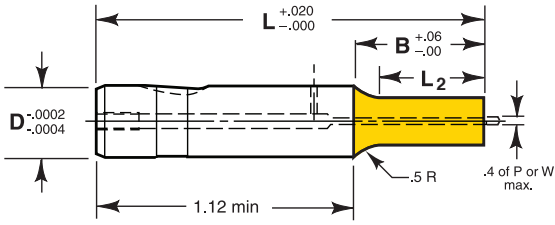

Steel: M2 Rc 60-63

TOLERANCES

Round P $\begin{matrix} +.0005 \\ -.0000 \end{matrix}$ ◎ .0005 P to D

Shape P, W $\pm .0005$ ◎ .001 P, W to D

Back Draft .001/inch L2 max.

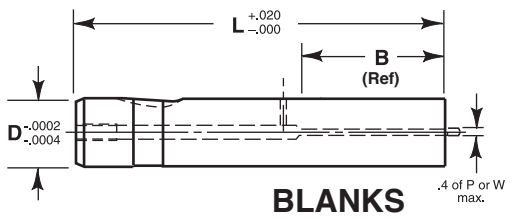

Ordering Example:

Qty Steel Type D B L P W
 12 M2 BRO 62 C x 3.00 P=.600 W=.250

Ordering Example:

Qty Steel Type D B L
 25 M2 BRB 50 C x 3.50

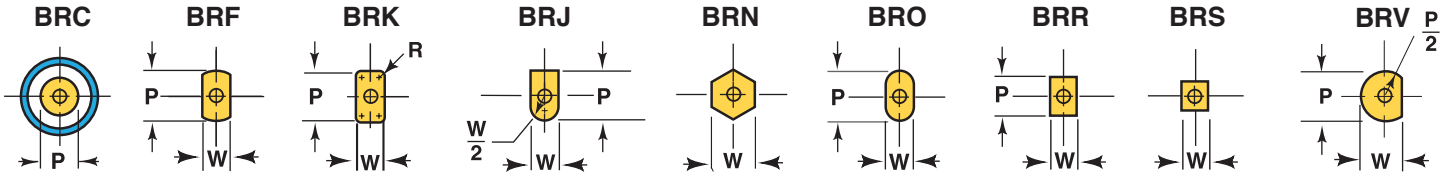
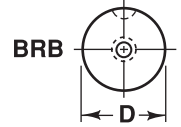

For additional standard forms and configurations see pages 30 - 33.

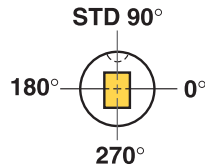

Standard ball seat location is at 90° using reflected view for punches. Alternate locations of 0°, 180° and 270° are available at no extra charge. Custom ball seat locations can be specified as number of degrees counterclockwise from 0° Example call out: BS 180°

Shank		Point Length B				Lengths L in .25" Increments	Point			Replacement Retrako Kit*
D	Code No	Standard	Alternates				Round	Shape		
		S	B(.75)	C(1.0)	D(1.25)		Range P	Min W	Max P/G	
.250	25	.500	●			2.00 thru 3.50	.062 - .249	.062	.249	K2I
.375	37	.625	●	●		2.00 thru 4.00	.125 - .374	.125	.374	K4I
.500	50	.750	●	●	●	2.00 thru 4.00	.187 - .499	.187	.499	K6I
.625	62	.875	●	●	●	2.25 thru 4.00	.312 - .624	.250	.624	K6I
.750	75	.937	●	●	●	2.25 thru 4.00	.437 - .749	.312	.749	K9I
.875	87	.937	●	●	●	2.25 thru 4.00	.625 - .874	.375	.874	K9I
1.000	100	.937	●	●	●	2.25 thru 4.00	.750 - .999	.437	.999	K9I
1.250	125	1.000	●	●	●	2.25 thru 4.00	.875 - 1.249	.500	1.249	K12I

*Ejector kits available see page 35 for details. Retrako Punches 1.25 ϕ = no side hole.

Standard Alterations are changes that are beyond the ranges listed in the catalog that can be altered for a minimal charge. See page 36.

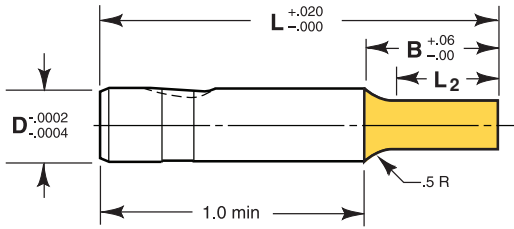

Steel: M2 Rc 60-63

TOLERANCES

Round P $\begin{matrix} +.0005 \\ -.0000 \end{matrix}$ ◎ .0005 P to D

Shape P, W $\pm .0005$ ◎ .001 P,W to D

Back Draft .001/inch L2 max.

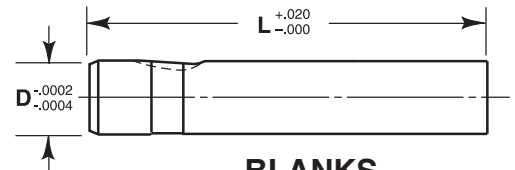

BLANKS

Ordering Example:

Qty Steel Type D B L P
12 M2 BC 62 S x 3.00 P.600

Ordering Example:

Qty Steel Type D L
25 M2 BB 62 x 4.75

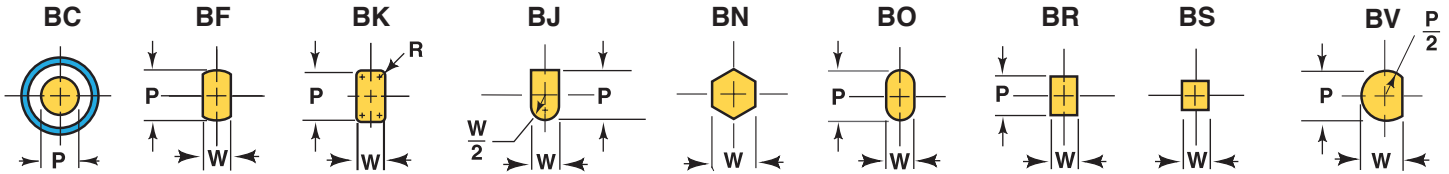
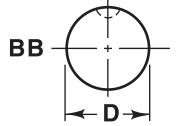

For additional standard forms and configurations see pages 30 - 33.

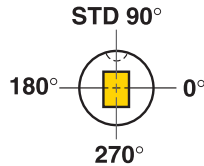

Standard ball seat location is at 90° using reflected view for punches. Alternate locations of 0°, 180° and 270° are available at no extra charge. Custom ball seat locations can be specified as number of degrees counterclockwise from 0° Example call out: BS 180°

Shank		Point Length B				Lengths L in .25" Increments	Point		
D	Code No	Standard	Alternates				Round	Shape	
		S	B(.75)	C(1.0)	D(1.25)	Range P	Min W	Max P/G	
.250	25	.500	●			2.00 thru 4.00	.062 - .249	.062	.249
.375	37	.625	●	●		2.00 thru 4.50	.125 - .374	.125	.374
.500	50	.750	●	●	●	2.00 thru 6.00	.187 - .499	.187	.499
.625	62	.875	●	●	●	2.25 thru 5.00	.312 - .624	.250	.624
.750	75	.937	●	●	●	2.25 thru 6.00	.437 - .749	.312	.749
.875	87	.937	●	●	●	2.25 thru 6.00	.625 - .874	.375	.874
1.000	100	.937	●	●	●	2.25 thru 6.50	.750 - .999	.437	.999
1.250	125	1.000	●	●	●	2.25 thru 4.25	.875 - 1.249	.500	1.249

Standard Alterations are changes that are beyond the ranges listed in the catalog that can be altered for a minimal charge. See page 36.

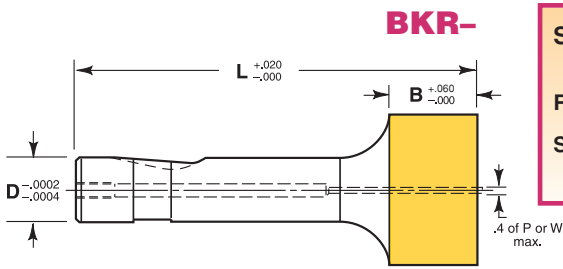

Steel: M2 Rc 60-63	
TOLERANCES	
Round P	+ .0005 - .0000
Shape P, W	± .0005
◎	.0005 P to D
◎	.001 P,W to D

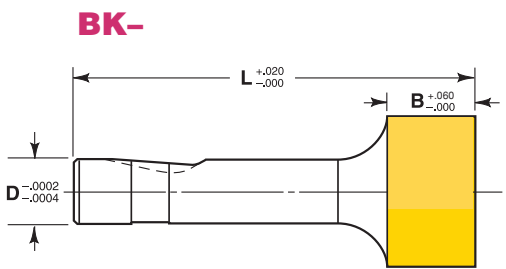

Ordering Example:

Qty Steel Type D L P
6 M2 BKRC 100 x 3.00 P 1.125

Ordering Example:

Qty Steel Type D L P W
3 M2 BKO 75 x 3.00 P.890 W.600

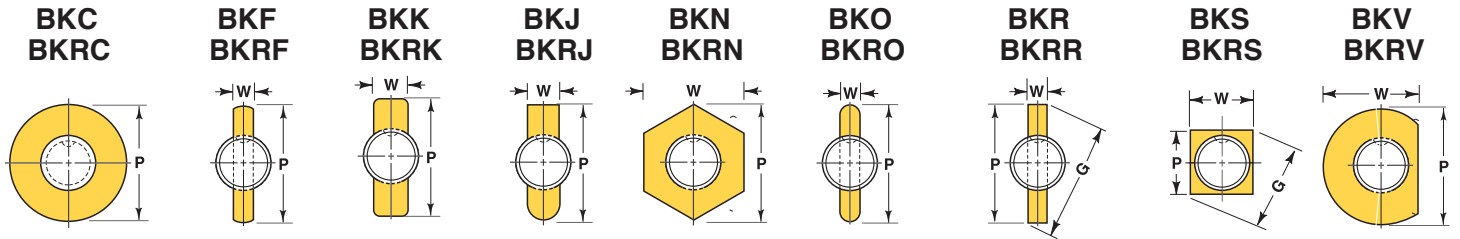

For additional standard forms and configurations see pages 30 - 33.

Shank		Point Length B	Lengths L in .25" Increments				Point			Replacement Retracto Kit*	
D	Code No.						Round	Shape			
							Range P	Min W	Max P/G		
.375	37	.625	3.00	3.25	3.50	3.75	4.00	.376 - 1.000	.125	1.000	K4I
.500	50	.750	3.00	3.25	3.50	3.75	4.00	.501 - 1.250	.188	1.250	K6I
.625	62	.875	3.00	3.25	3.50	3.75	4.00	.626 - 1.500	.250	1.500	K6I
.750	75	.937	3.00	3.25	3.50	3.75	4.00	.751 - 1.500	.312	1.500	K9I
.875	87	.937	3.00	3.25	3.50	3.75	4.00	.876 - 1.750	.375	1.750	K9I
1.000	100	.937	3.00	3.25	3.50	3.75	4.00	1.001 - 1.750	.437	1.750	K9I

*Ejector kits available see page 35 for details.

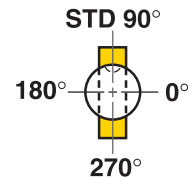

Standard ball seat location is at 90° using reflected view for punches. Alternate locations of 0°, 180° and 270° are available at no extra charge. Custom ball seat locations can be specified as number of degrees counterclockwise from 0°.

Standard Alterations are changes that are beyond the ranges listed in the catalog that can be altered for a minimal charge. See page 36.

Regular Parabolic Pilot-BP

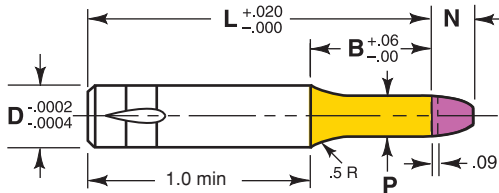

Steel: M2 Rc 60-63

P $\begin{matrix} +.0005 \\ -.0000 \end{matrix}$

© .0005 P to D

B & L Lengths do not include Pilot Tip N

Ordering Example:

Qty Steel Type D B L P
8 M2 BP 50 S x 2.50 P.400

Pilot Type	Body D Ø	Point Length B				Length L in .25" Increments	Range P	N
		Std.	Alternates					
		S	B(.75)	C(1.0)	D(1.25)			
BP25	.250	.50	●			2.00 thru 3.75	.061 – .249	.250
BP37	.375	.63	●	●		2.00 thru 4.25	.124 – .374	.250
BP50	.500	.75	●	●		2.00 thru 5.75	.186 – .499	.250
BP62	.625	.87	●	●	●	2.00 thru 4.75	.311 – .624	.250
BP75	.750	.94	●	●	●	2.25 thru 5.75	.436 – .749	.250
BP87	.875	.94	●	●	●	2.25 thru 5.75	.624 – .874	.250
BP100	1.000	.94	●	●	●	2.25 thru 5.75	.749 – .999	.250
BP125	1.250	1.00	●	●	●	2.25 thru 4.00	.874 – 1.249	.250

Angular Pilot-BAP Type

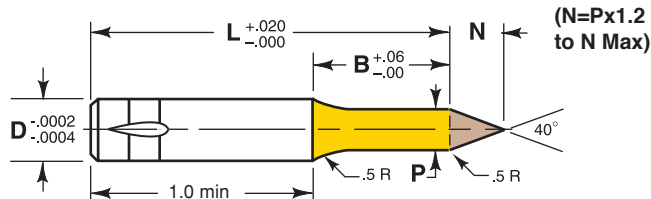

B & L Lengths do not include Pilot Tip N

Ordering Example:

Qty Steel Type D B L P
4 M2 BAP 87 B x 4.00 P.700

Pilot Type	Body D Ø	Point Length B				Length L in .25" Increments	Range P	N MAX
		Std.	Alternates					
		S	B(.75)	C(1.0)	D(1.25)			
BAP37	.375	.63	●	●		2.50 thru 4.00	.186 – .374	.375
BAP50	.500	.75	●	●	●	2.50 thru 5.50	.249 – .499	.500
BAP62	.625	.87	●	●	●	2.50 thru 4.25	.311 – .624	.625
BAP75	.750	.94	●	●	●	2.50 thru 5.25	.436 – .749	.750
BAP87	.875	.94	●	●	●	2.75 thru 5.00	.624 – .874	.875
BAP100	1.000	.94	●	●	●	3.00 thru 5.00	.749 – .999	1.000

Standard Alterations are changes that are beyond the ranges listed in the catalog that can be altered for a minimal charge. See page 36.

Forms

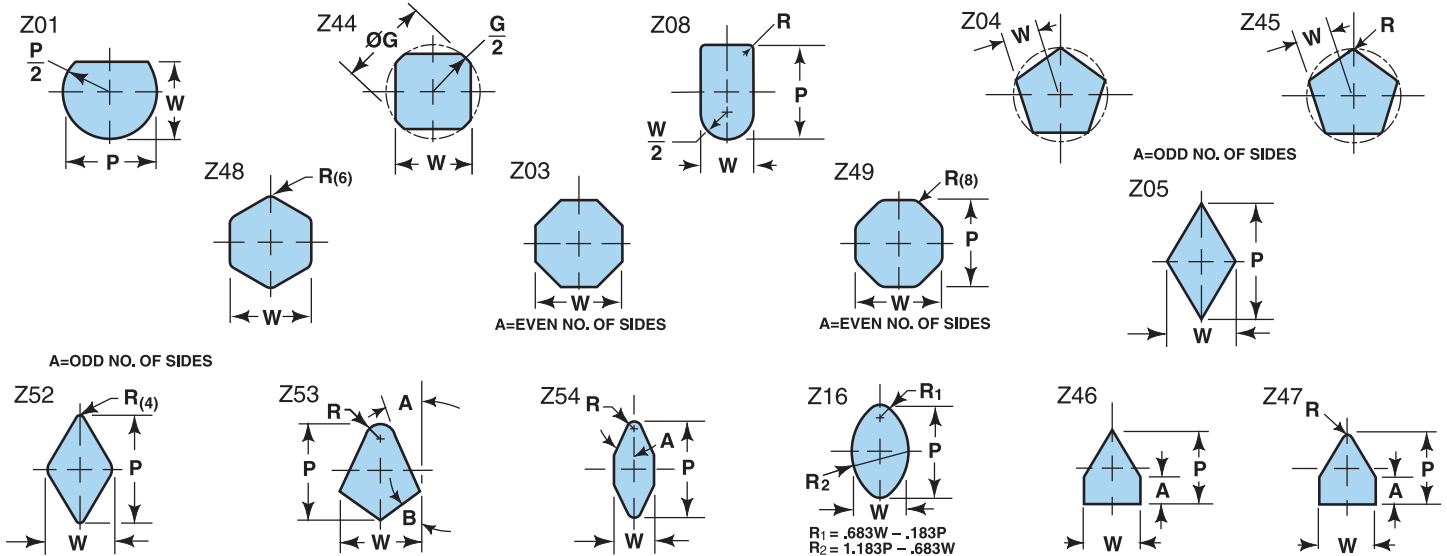

Triangles & Trapezoid Forms

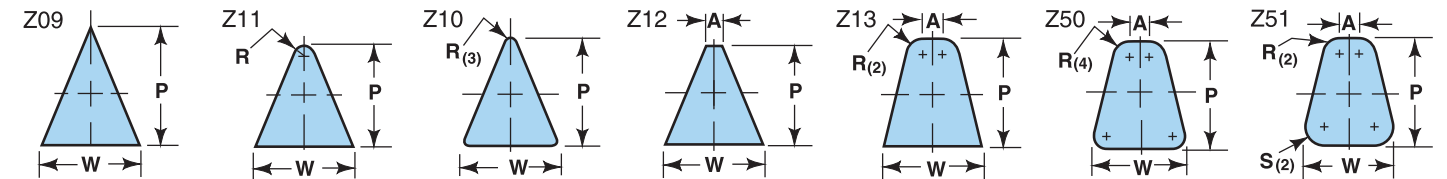

Keyhole & Teardrop Forms

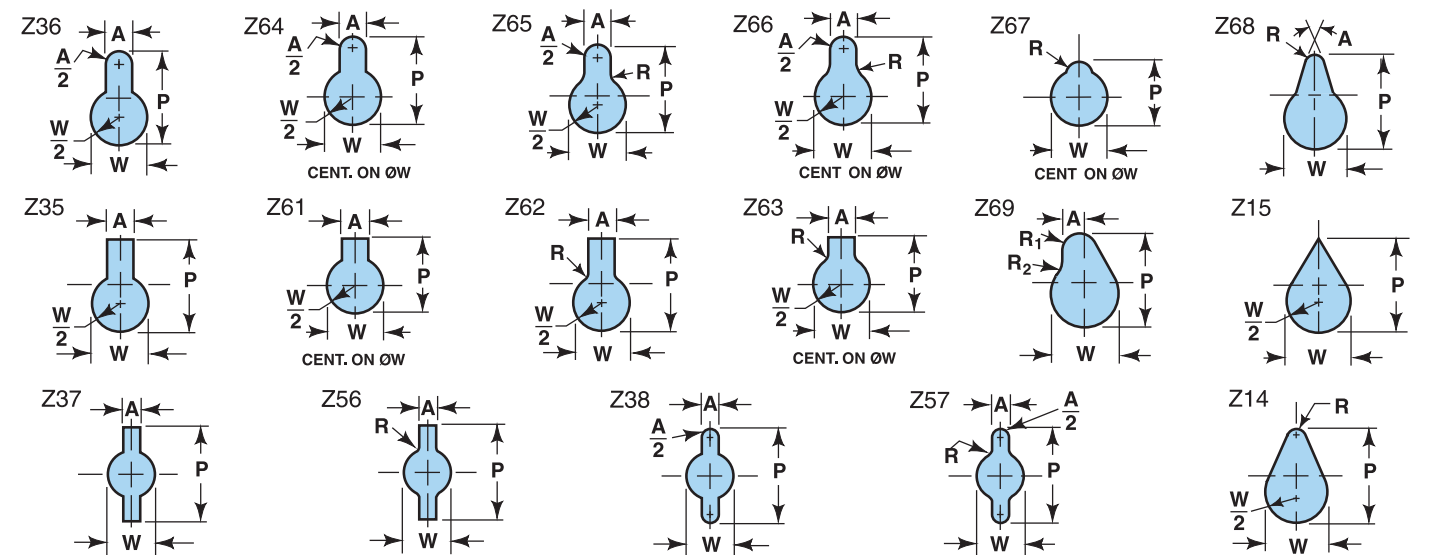

Knock-Out Forms

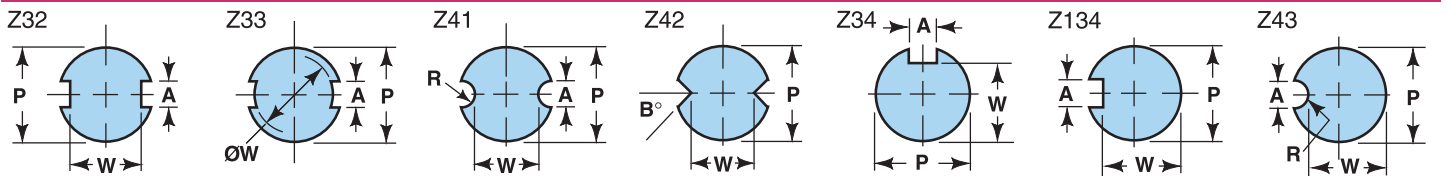

In cases where clearance per side (\emptyset) is $.0025\emptyset$ or less Porter will break the sharp corners to eliminate interference, when punches, and/or guides and dies are ordered together.

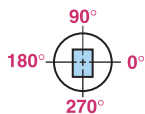

VIEWS: Shown as in-die position. This is reflected view for punch and guide, plan view (thru cutting end) of die button. See page 39 for details.
CENTERING: Forms are centered to the shank or body as shown. Exception being forms Z09 and Z15, will not be centered on P due to clearance.

When Ordering Forms Specify: Qty 5 Mat. M2 Style () Z 37 C B L 2.50 Form Z-06 P .300 W .235 R .060 Locate LMI

U Shape Forms

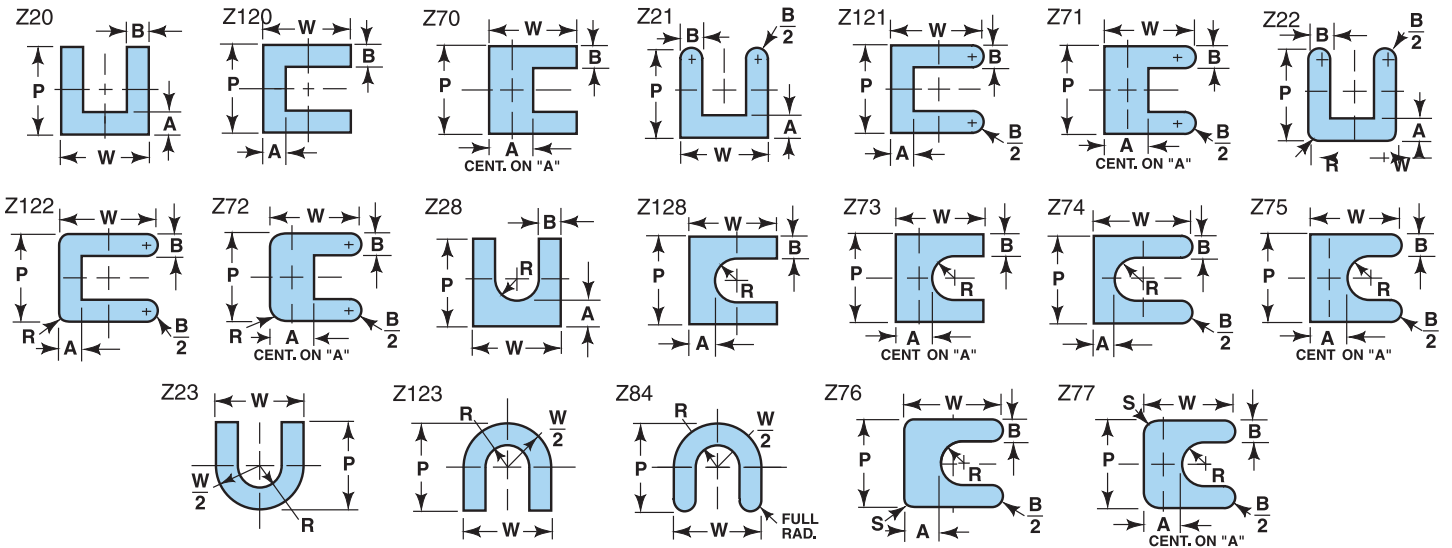

L Shape Forms

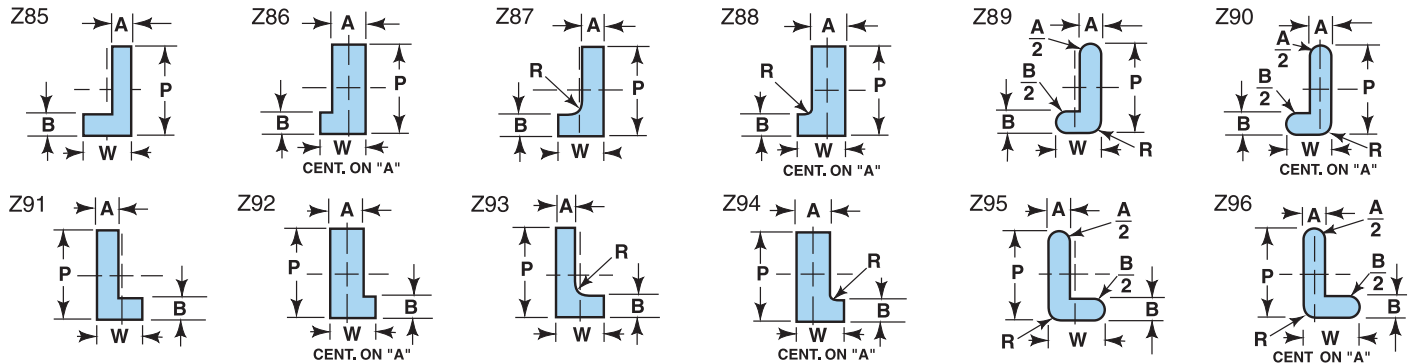

Spline Shape Forms

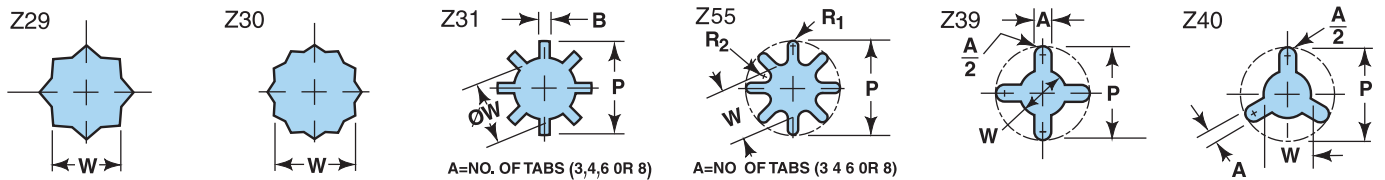

Knock-Out Forms

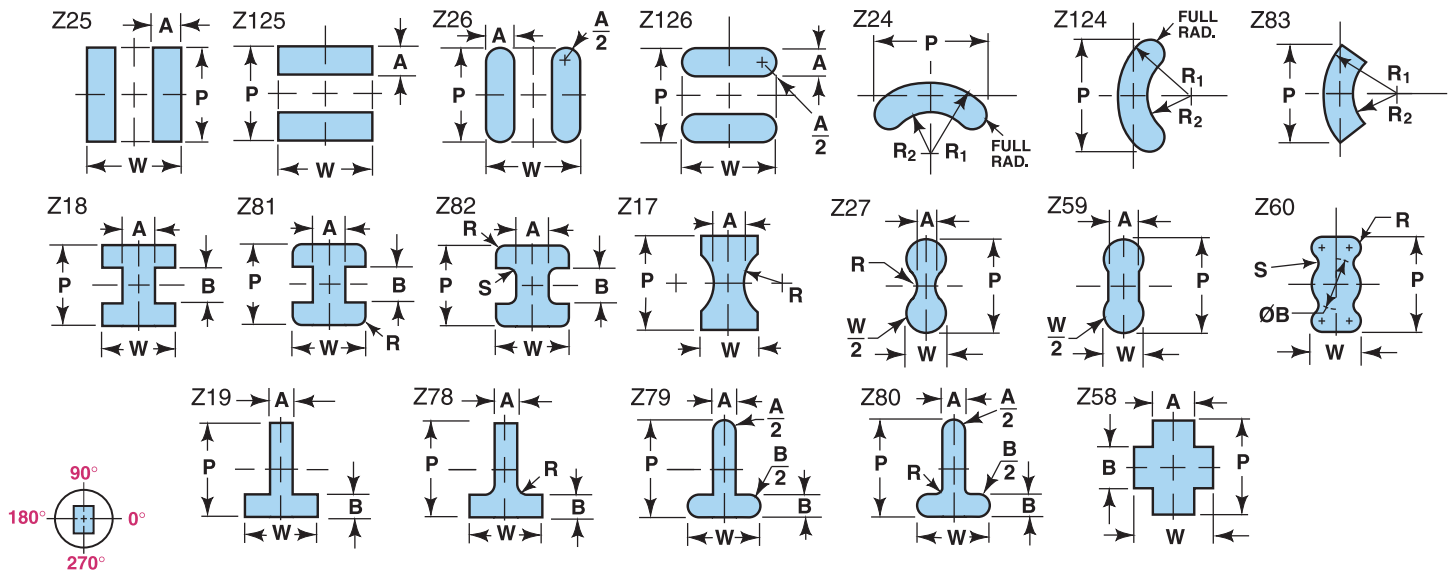

ORIENTATION: Bal-Lok Punch and Die Button Standard Ballseat location is at 90°. For all else standard flat and dowel location is at 0°. Alternate and custom locations are also available, see orientation guidelines.

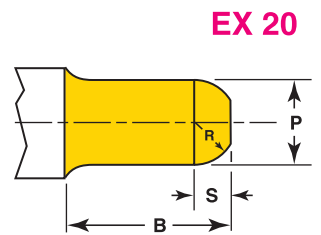
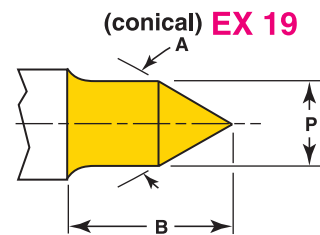
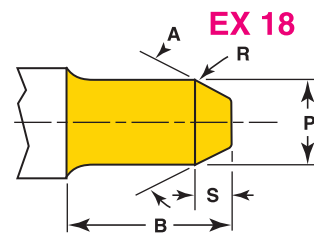
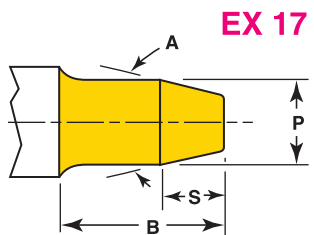
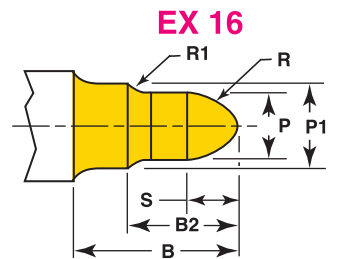
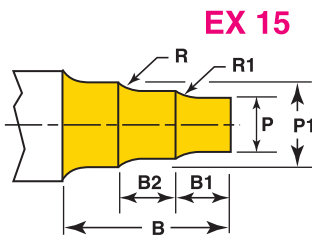
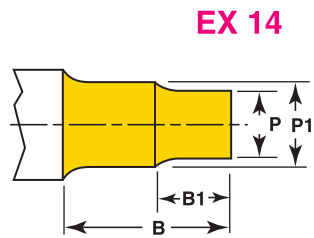
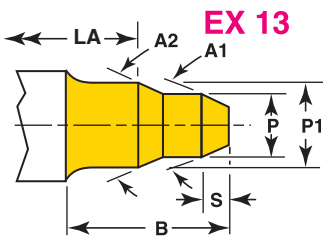
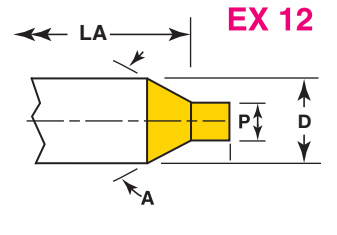
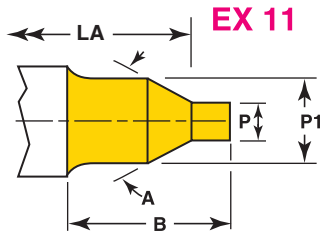
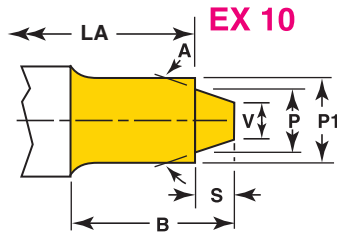
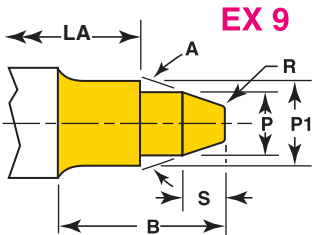
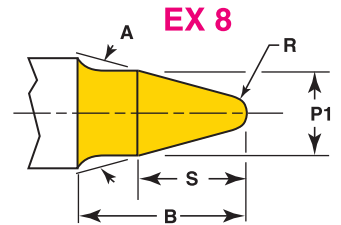
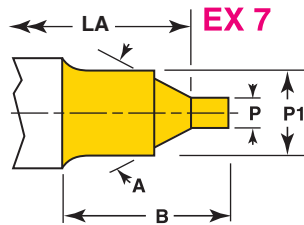
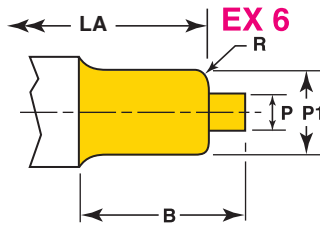
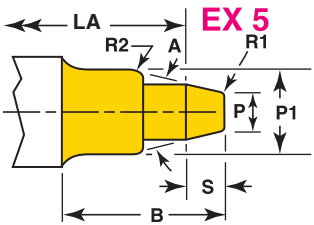
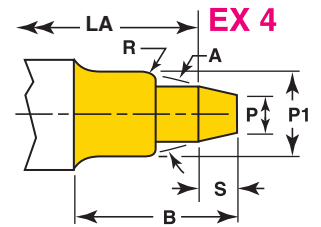
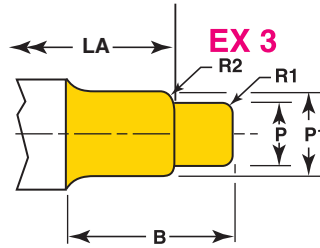
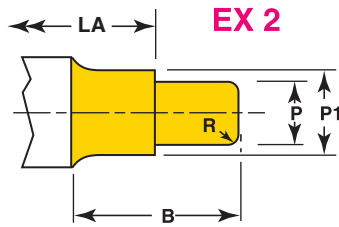
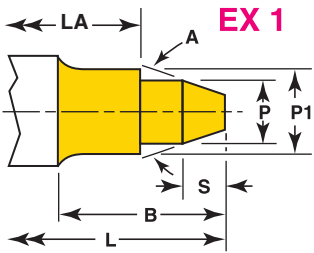
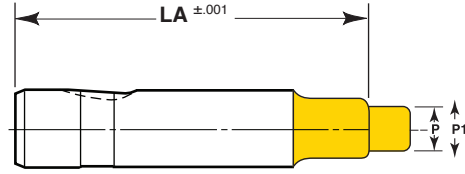
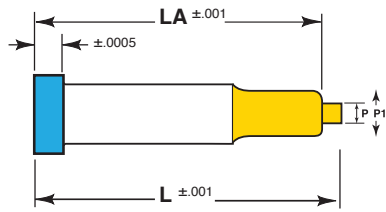

All shank to largest point diameter will be supplied with .5 radius blend unless otherwise specified. All inside corners will be supplied with .016 radius blend unless otherwise specified.

EX-LP

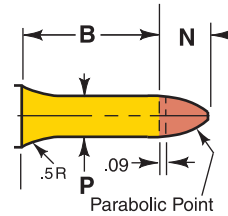
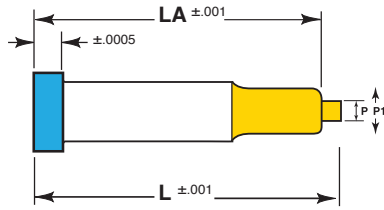

(ball) EX 21

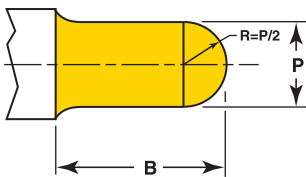

EX 22

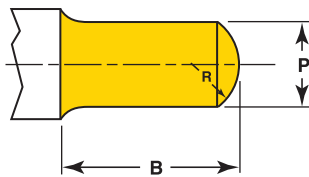

EX 23

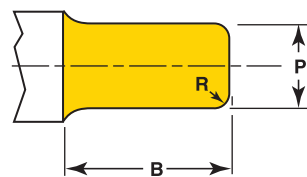

EX 24

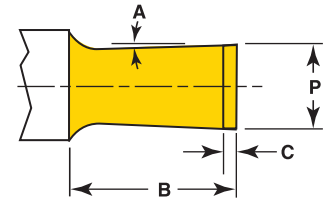

All shank to largest point diameter will be supplied with .5 radius blend unless otherwise specified. All inside corners will be supplied with .016 radius blend unless otherwise specified.

For LA information see panel on page 35.

EX-25 Pick Up Perforate

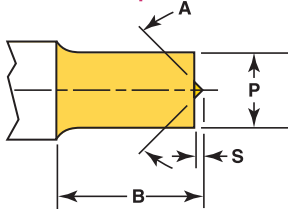

EX-26 Angle Shear

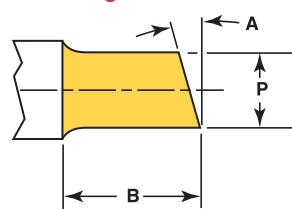

EX-27

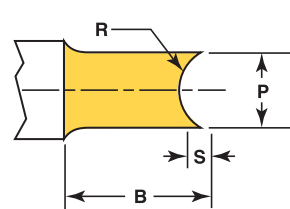

EX-28 Dimple

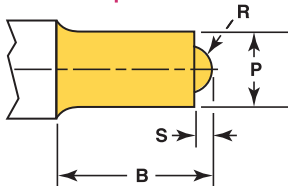

EX-29 Rooftop

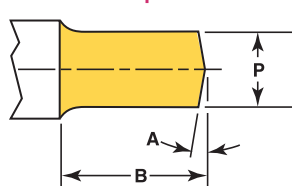

EX-30 Inverted Rooftop

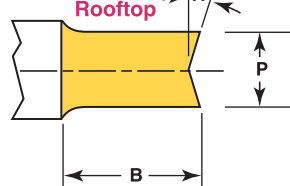

EX-31 Nail Point 4 Sided

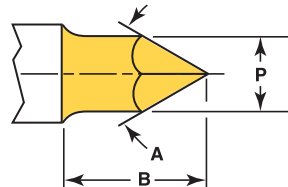

EX-32 Nail Point 3 Sided

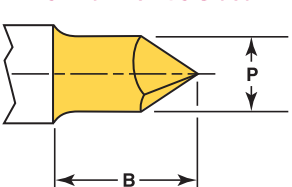

EX-33

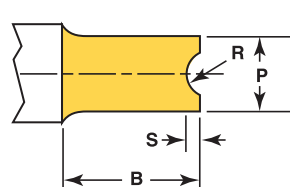

Ex. 1 thru Ex. 33 tips are available on all standard catalog range punches. (Head type, Headless and Bal-Lok Solid and Retrako.)
Use caution when using Retrako type in relation to point length (P) and smallest point Ø (P). Some tips are not compatible with Retrako use. (Example # Ex. 31)

When no B (point length) is called out, the standard B for the type punch selected will be supplied. All Ultra Precision style must call out B length as there are more than one standard available for this style punch.

Common type of extrusion punches are shown above and can be configured on any style punch as called out by the customer. Configurations of other styles can be furnished upon receipt of customer drawings with specified tolerances.

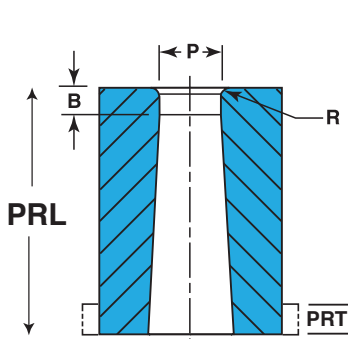

EX-40

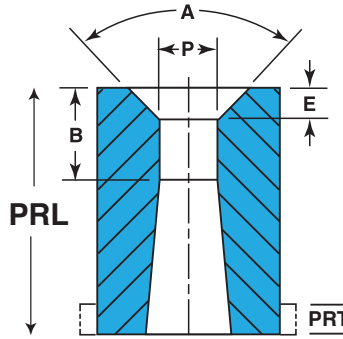

EX-41

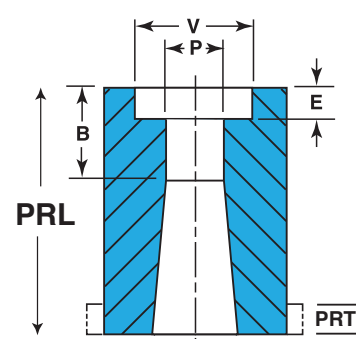

EX-42

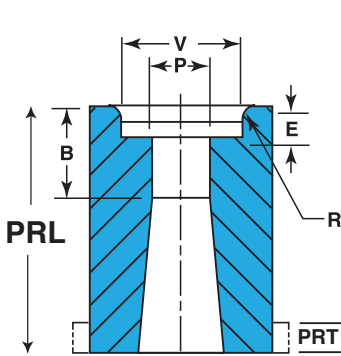

EX-43

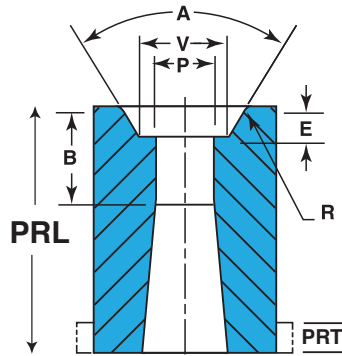

EX-44

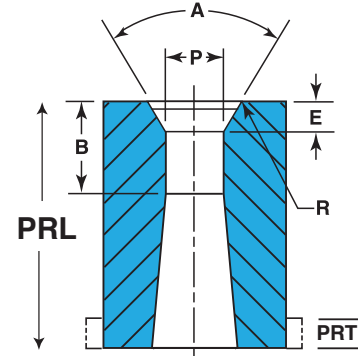

EX-45

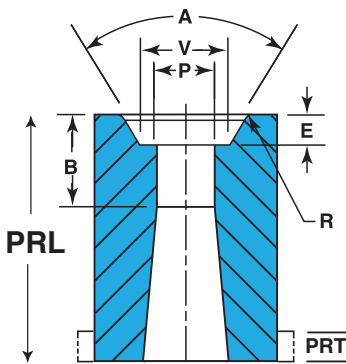

EX-46

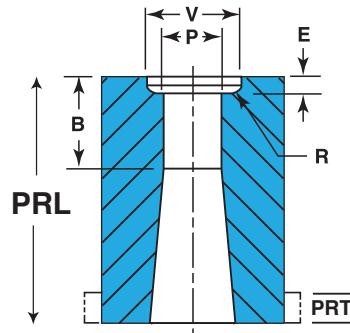

EX-47

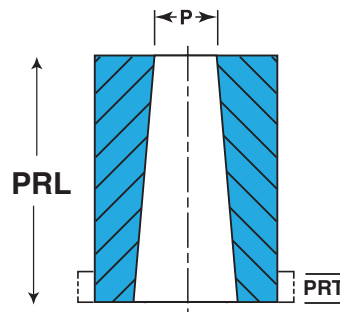

EX-48

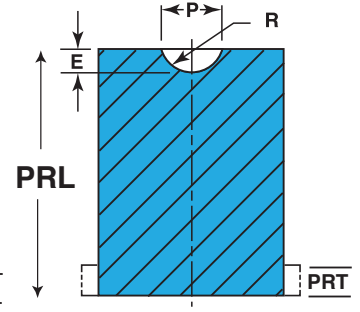

EX-49

Standard materials used on any of these will be M2 with RC of 60-63 unless called out by the customer to be otherwise. Other configurations can be manufactured with drawings submitted by the customer.

PORTER® Marking Punches and Custom Stamps

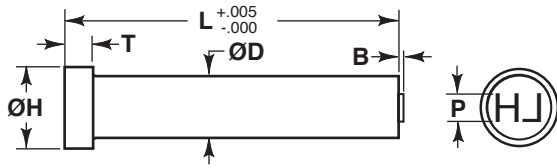

Many custom stamps and marking punches are available from Porter. Please identify punch style as part of the order. All tolerances on punch body other than (L) will be manufactured to catalog standards unless otherwise specified by the customer.



Ordering Example (Specify punch style) Drawings Required

Qty	Steel Type	D	L	P	B
12	M-2 ()MP	50	x 3.00	P=.375	.093

PORTER® Retrako Replacement Components

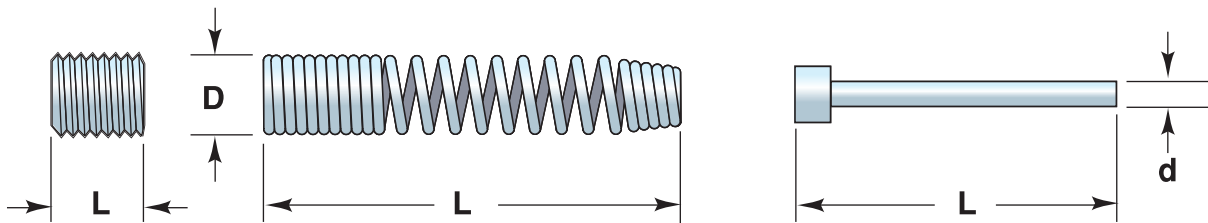
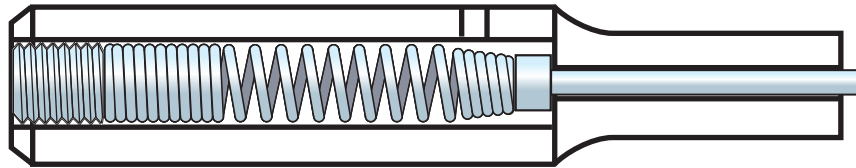

Replacement Retrako Kit	Punch Type		Set Screw Size/Length	Spring			Pin			Pin Extension Length
	Headed	Bal-Lok		Hole-D	D	L	Hole	L	d	
K2I	18	25	3-48 x 1/8	.086	.081	2	.020	1.11	.017	.03
K3I	25	N/A	5-40 x 1/8	.109	.104	2 1/2	.032	1.38	.027	.03
K4I	31	37	8-32 x 3/16	.141	.136	2 7/8	.046	1.94	.041	.06
K6I	37-50	50-62	10-32 x 1/4	.172	.167	2 7/8	.063	1.94	.058	.06
K9I	62-100	75-100	1/4-28 x 1/4	.221	.216	3	.094	2.22	.089	.06
K12I	125 &>	125	5/16-24 x 1/4	.275	.270	3	.125	2.22	.120	.06

Kit includes 1 each – set screw
 – spring
 – pin
 Components available as kits or separately.

Retrako Springs and pins are cut to length at assembly.

Alterations beyond standard ranges listed in the catalog that can be accomplished for a slight additional charge. Alterations beyond those listed consult factory. Standard catalog tolerances are used for all alterations unless otherwise specified

RL = Reduce Length (L)

- Punches- Stock is removed from the point end, also reducing the point length (B)
- Die Buttons-Headless (Excluding Bal-Lok). Stock is removed from the Co-bore end. Head Type with Co-Bore relief. Stock is removed from the I.D. end shortening the (B).
- Taper dies "RL" will not reduce land length

AB = Alter "B" Length on Punches or Buttons

- Reduction is from I.D. end of buttons shortening "L" on HND style

RLB = Reduced Length Maintain "B"

PRL = Precision Reduced Length

- Same as "RL" plus "L" is held to $\pm .001$

RD = Reduced Diameter of Shank or Body

- Max standard reduction .040 (for further reduction consult factory). "H" remains the same.

RP = Reduce "P" on Round Punches

- (See Chart for standard ranges or consult factory)

RW = Reduce "W" on Shape Punches

- (See Chart for standard ranges or consult factory)

RT = Reduce Head Thickness

- Stock removed from under the head (does not reduce "OAL")

RTL = Reduce Head Thickness

- Stock removed from the top of the head (reduces "L")

PRT = Precision Reduced Head Thickness

- Same as RT. "T" is held to $\begin{matrix} +.001 \\ -.000 \end{matrix}$

RH = Reduce Head Diameter

- Max standard reduction .062 (further reduction consult factory)

LPC = Longer Point Circular

- Solid Punches Only
- Specify "B" length up to 1.75
- Minimum body Length shown in catalog (further reduction consult factory)

LPW = Longer Point Shape

- Solid Punches Only
- Specify "B" length up to 1.75
- Minimum body Length shown in catalog (further reduction consult factory)

AP = Alter "P" on Round Dies

- Standard dies up to .020 over listed range (Greater increases require "AR")
- Taper dies (See Chart)

AW = Alter "W" on Shape Dies

- Standard dies up to .020 over listed range (Greater increases require "AR")
- Taper dies (See Chart)

AR = Alter Relief on Co-Bore Dies

- Round Relief Only

IB = Increase Land "B" on Die Buttons

- Taper Dies {P or W .050-.250 (.250) max}
- { P or W .251 and over (.500) max} [longer consult factory]

SK = Slug Keeper

- Slug Retention System

AT = Alter Taper

RP-Reduce P Chart

BODY	PRC RC HEC XRC CDRC	PC SC HC XSC CDSC	PLP PP PAP SLP SAP SP CDSAP	HBRC	BRC	BC HBC	HBLP HBAP HBP BLP BAP BP
12		.042					
18	.050	.042	.041				
25	.080	.062	.041		.050	.050	.050
31	.115	.062	.061				
37	.158	.062	.091	.062	.115	.050	.083
43	.158	.158	.092				
50	.158	.158	.124	.158	.158	.093	.092
62	.235	.235	.234	.158	.158	.125	.124
75	.300	.300	.299	.235	.235	.235	.234
87	.350	.350	.399	.300	.300	.300	.299
100	.400	.400	.399	.350	.350	.350	.349
125	.450	.450	.450	.450	.450	.450	.499

RW-Reduce W Chart

BODY	PRO PRR PRS PRF CDRO CDRR CDRS CDRF	PO PR PO PF CDSO CDSR CDS CDSF	RO RR RS RF XRO XRR XRS XRF	SO SR SS SF XSO XSR XSS XSF	HBRO HBRR HBRS HBRF	HBO HBR HBS HBF	BRO BRR BRS BRF	BO BR BS BF
12		.062		.062				
18	.062	.062	.062	.062				
25	.080	.062	.080	.062			.050	.040
31	.115	.062	.115	.062				
37	.158	.080	.158	.080	.062	.050	.115	.050
43	.158	.109	.158	.158				
50	.158	.125	.158	.158	.158	.093	.158	.093
62	.235	.235	.235	.235	.158	.125	.158	.125
75	.235	.235	.235	.235	.235	.235	.235	.235
87			.235	.235	.235	.235	.235	.235
100	.235	.235	.235	.235	.235	.235	.235	.235
125	.281	.250	.281	.250	.235	.235	.281	.250

AP-Alter P Chart

Inch Body Ø	MaxP/W/G
.1875	.130
.2500	.190
.3125	.240
.3750	.290
.4375	.340
.5000	.390
.6250	.500
.7500	.600
.8750	.700
1.0000	.800
1.2500	1.000
1.5000	1.200

AR-Alter RØ Chart

Inch Body Ø	MaxP/W/G
.312	.255
.375	.315
.437	.355
.500	.405
.625	.520
.750	.625
.875	.730
1.000	.830
1.250	1.030
1.500	1.230

VIEWS

All views are shown as in die position view. This is the reflected (thru shank) view for the punch and guide, and is the plain view (thru I.D. end) for the die button (matrix). This view is consistent whether for headed and press fit items or Bal-Lok items.

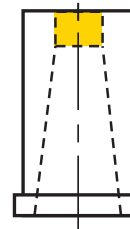
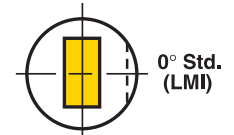
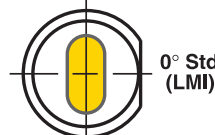
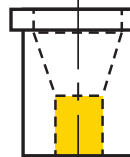
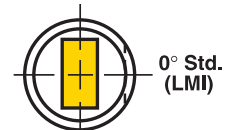
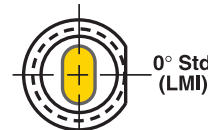
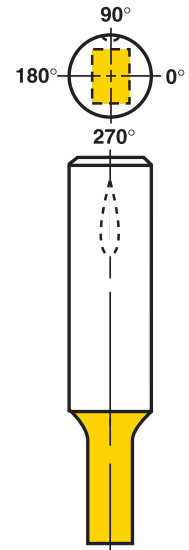
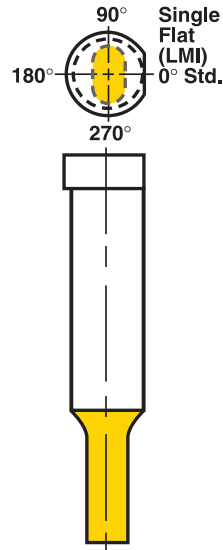

ORIENTATION

On Headed and Press Fit punches, die buttons and guide bushings the standard keying location is at 0° (on the long side of the standard shape). Custom locations are available and called out as the number of degrees counter clockwise from 0° (**Example: LM1@45°**)

BAL-LOK Punches and Die Buttons.

The standard ball-seat keying location is at 90°, (in the end zone if looking at a football field). Custom locations are available and called out as the number of degrees counter clockwise from 0° (**Example: BS@45°**)

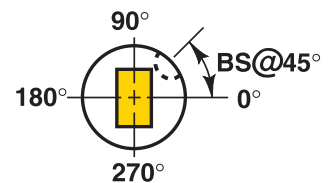
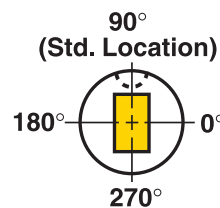

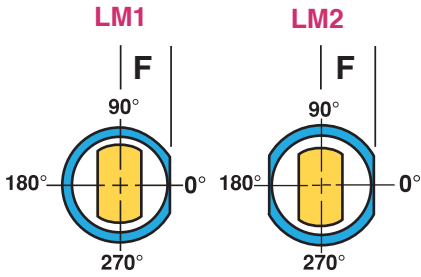

TOLERANCES ON ALL FLATS

Standard Precision F= ± 0.001 to C/L
 $.001/1.000$ Parallel

Ultra Precision F= ± 0.0004 to C/L
 $.0005/1.000$ Parallel

Flat Length ± 0.010
 -0.000

LM3

LM3

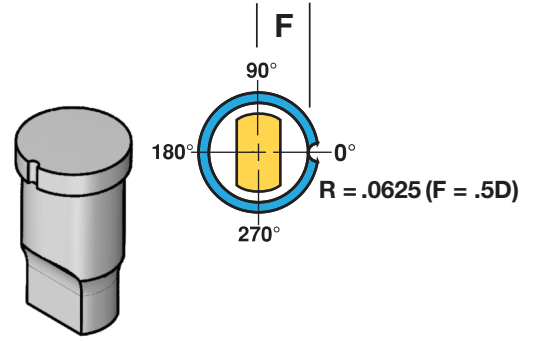

Standard Locating Methods

Flat	F =	Depth
LM1	F =	.5D
LM2	F =	.5D
LM3	F =	.5D (R=.0625)

All above locating methods are supplied at standard location (0°) "Alternate locations are available at no extra charge" Call out (LM1@90)

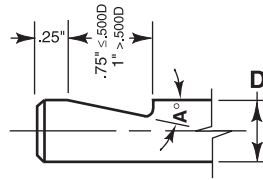

For Shape and Form Headless Punches **Specify LM7** relation to shape. Standard location is at 0° Alternate angles are available **Specify LM7 A=12°**

STD LM-7

D	A°
.25 .31 .37	5°
.50	7.5°
.62 - 2.50	10°

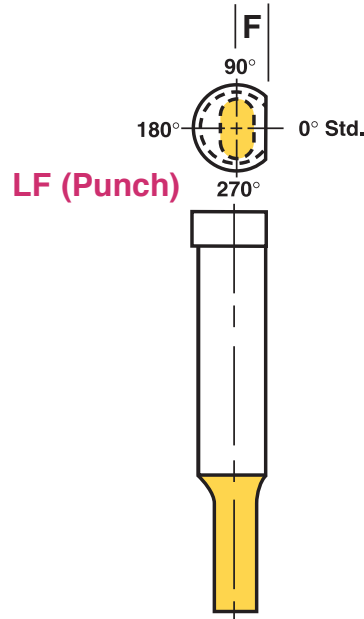
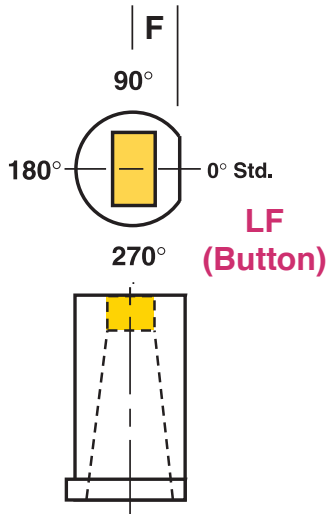

Full Length Die Flat		
LF1	F =	.5D-.060
LF11	F =	.5D-.093
LF12	F =	Specify

Full Length Punch Flats		
LF2	F =	.5D-.060
LF21	F =	.5D-.093
LF22	F =	Specify

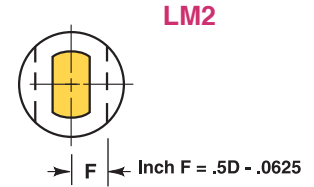
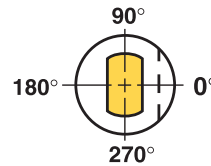
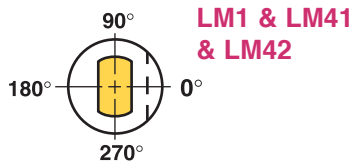
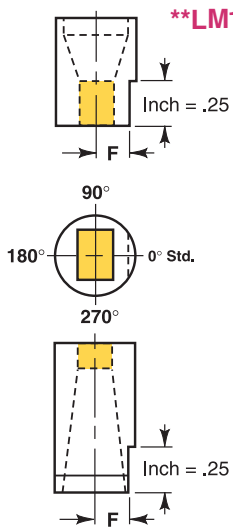

Call Out	D*	F Dimension Listing																			
		.18	.25	.31	.37	.43	.50	.62	.75	.87	1.00	1.12	1.25	1.37	1.50	1.62	1.75	2.00	2.25	2.50	2.75
LM1	F =	.5D - .0625																			
LM2	F =	.5D - .0625																			
LM41	F =	.080	.110	.135	.165	.190	.220	.270	.325	.380	.435	.4875	.540	.5875	.650	.7125	.775	.900	1.025	1.150	1.275

*Additional variations available (consult factory or supply drawings of requirement)

**Above flats available on Cutting end at no additional charge (Example LM1C)

TOLERANCES ON ALL FLATS

Standard Precision F = $+.001$ to C/L
 $-.0000$

.001/1.000 Parallel

Ultra Precision F = $+.0004$ to C/L
 $-.0000$

.0005/1.000 Parallel

Flat Length $+.010$
 $-.000$

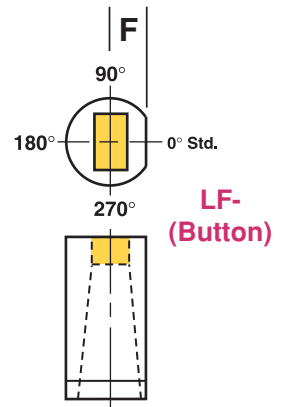

Full Length Die Flat		
LF1	F =	.5D-.060
LF11	F =	.5D-.093
LF12	F =	Specify

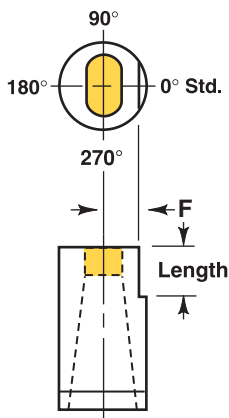

LM43, LM44, LM45, LM46, LM47, LM48, LM49
(Flat is on cutting-End)

Call Out	F	Length
LM43	.5D-.060	.50
LM44	.5D-.060	.62
LM45	.5D-.060	.75
LM46	SPECIFY	
LM47	.5D-.093	.50
LM48	.5D-.093	.62
LM49	.5D-.093	.75

LM (6, 63, 64, 66)

Headless Die Button
Guide Bushing

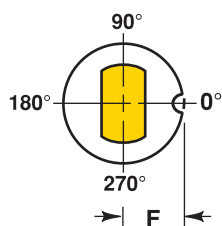

Inch Dowel Slot												
Call Out	Dowel Dia.	D=	25	31	37	43	50	62	75	87	100	125-275
LM6	.125	F =	.125	.1562	.1875	.2188	.250	.5D	.5D	.5D	.5D	.5D
LM63	.125	F =	.1625	.1875	.2125	.2375	.2625	.5D	.5D	.5D	.5D	.5D
LM64	.1875	F =	.1938	.2188	.2438	.2688	.2938	.5D	.5D	.5D	.5D	.5D
LM66	.250	F =	.225	.250	.275	.300	.325	.343	.4063	.4688	.5313	.5D

Durathane

Open End Punch Strippers

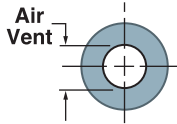
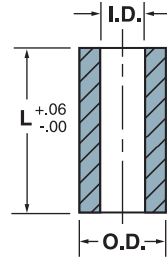

Ordering Example:
Quantity Description
6 O62-175

All are oil and solvent resistant 95A durometer. All provide greater pressures than equal sized steel die springs. All are easy to install and dampen vibration. Pop-On's closed end gives more positive stripping and full stripping around periphery of punch point.

Pop-On

Closed End Punch Strippers

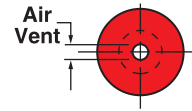
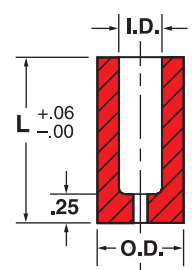

Ordering Example:
Quantity Description
7 U37-125

I.D. Inch	O.D. Inch	Length L Inch	Catalog Number	Approx. Stripping Pressure in Lbs. at deflection of		
				.187	.281	.437
.250	.750	1.25	O25-125	280		
		1.50	O25-150	275	465	
		1.75	O25-175	220	375	490
.312	.812	1.25	O31-125	320		
		1.50	O31-150	300	450	
		1.75	O31-175	270	400	575
		2.00	O31-200	240	370	600
.375	.875	1.25	O37-125	420		
		1.50	O37-150	385	625	
		1.75	O37-175	355	575	760
		2.00	O37-200	310	515	670
.500	1.000	1.25	O50-125	520		
		1.50	O50-150	450	725	
		1.75	O50-175	435	680	875
		2.00	O50-200	315	510	650
.625	1.125	1.25	O62-125	600		
		1.50	O62-150	520	835	
		1.75	O62-175	480	775	1000
		2.00	O62-200	440	730	935
.750	1.500	1.75	O75-175	500	800	1200
		2.00	O75-200	400	700	1100
		2.25	O75-225	350	650	1000
		2.50	O75-250	325	600	900
		2.75	O75-275	300	550	800
.875	1.750	1.75	O87-175	1500	2200	3400
		2.00	O87-200	1200	1900	2800
		2.25	O87-225	1150	1850	2400
		2.50	O87-250	900	1450	1900
		2.75	O87-275	850	1350	1800
1.000	2.000	1.75	O100-175	2000	3000	3500
		2.00	O100-200	1600	2600	3400
		2.25	O100-225	1400	2300	3200
		2.50	O100-250	1200	2000	3000
		2.75	O100-275	1000	1800	2800

I.D. Inch	O.D. Inch	Length L Inch	Catalog Number	Approx. Stripping Pressure in Lbs. at deflection of		
				.125	.25	.375
.187	.688	1.25	U18-125	250	400	
		1.50	U18-150	230	350	
.250	.750	1.25	U25-125	280	475	
		1.50	U25-150	275	465	
		1.75	U25-175	220	375	490
.312	.812	1.25	U31-125	320	500	
		1.50	U31-150	300	450	
		1.75	U31-175	270	400	575
		2.00	U31-200	240	370	600
.375	.875	1.25	U37-125	420	695	
		1.50	U37-150	385	625	
		1.75	U37-175	355	575	760
		2.00	U37-200	310	515	670
.500	1.000	1.25	U50-125	520	790	
		1.50	U50-150	450	725	
		1.75	U50-175	435	680	875
		2.00	U50-200	315	510	650
.625	1.125	1.25	U62-125	600	925	
		1.50	U62-150	520	835	
		1.75	U62-175	480	775	1000
		2.00	U62-200	440	730	935
.750	1.500	1.75	U75-175	500	800	1200
		2.00	U75-200	400	700	1100
		2.25	U75-225	350	650	1000
		2.50	U75-250	325	600	900
		2.75	U75-275	300	550	800
.875	1.750	1.75	U87-175	1500	2200	3400
		2.00	U87-200	1200	1900	2800
		2.25	U87-225	1150	1850	2400
		2.50	U87-250	900	1450	1900
		2.75	U87-275	850	1350	1800
1.000	2.000	1.75	U100-175	2000	3000	3500
		2.00	U100-200	1600	2600	3400
		2.25	U100-225	1400	2300	3200
		2.50	U100-250	1200	2000	3000
		2.75	U100-275	1000	1800	2800

HOT FORGED HEADS

OUTLAST THE OTHERS...

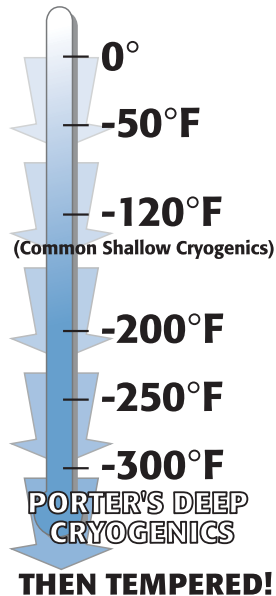

The Benefits

CRYOGENICS process forms very fine carbide particles throughout the material and increases wear resistance.

CRYOGENICS treatment results in a tougher substrate further increasing part life through reduced impact failures.

CRYOGENICS reduces internal stresses or completely eliminates part movement during the machining process.

CRYOGENICS requires only one treatment as it is a through part molecular change and not a surface layer. The results last the life of the tool. Sharpening will NOT eliminate the benefits.

CRYOGENICS is an exclusive combination of deep cryogenics (-300F) treatment plus an additional temper during the heat-treating process. This results in internally altering the entire structure of the steel creating a dense and uniform molecular structure. **CRYOGENICS** is not a surface treatment! **CRYOGENICS** increases internal bonding while releasing internal stresses created by previous machining processes. Computer-controlled gradual cooling and warming cycles eliminate the possibility of thermal shock and prevent parts from becoming brittle.

Tin Titanium Nitride

A (PVD) process of placing a thin coating of Titanium Nitride 1-5 microns thick over the working area of the punch.

Benefits

- * Surface hardness of 2300 Vickers
- * Dry coefficient of friction versus steel .4
- * Thermal stability up to 1100 F
- Appears gold in color

TIALN Titanium Aluminum Nitride

A (PVD) process of placing a thin coating of Titanium Aluminum Nitride 2-5 microns thick over the working area of the punch.

Benefits

- * Surface hardness of 3000 Vickers
- * Dry coefficient of friction versus steel .6
- * Thermal stability up to 1292 F
- * Appears grey

TICN Titanium Carbonitride

A (PVD) process of placing a thin coating of Titanium Nitride 1-5 microns thick over the working area of the punch.

Benefits

- * Surface hardness of 3000 Vickers harder than Carbide"
- * Dry coefficient of friction versus steel .3
- * Thermal stability up to 750 F
- * More wear resistance than TIN
- Appears brown or light blue.

P-41

A (PVD) process of placing a thin coating 1-8 microns thick over the working area of the punch.

Benefits

- * Surface hardness of 2000-2800 Vickers
- * Dry coefficient of friction versus steel .1
- * Thermal stability up to 550 F
- Appears black in color
- * More wear resistant than TICN
- * Specially for non ferrous materials
- * Appears grey

Porter Plus (PPC)

A (PVD) process of placing a thin layer of this special coating (2-5 microns thick) over the working area of the punch.

Benefits

- * Surface hardness of 3200 Vickers
- * Dry coefficient of friction versus steel .35
- * Thermal stability up to 2000 F
- * More wear resistant than TICN
- * Appears blue-grey

P-90

A (PVD) process of placing a thin coating 6-8 microns thick over the working area of the punch.

Benefits

- * Surface hardness of 3800 Vickers
- * Dry coefficient of friction versus steel .12
- * Thermal stability up to 750 F
- * More wear resistant coating
- * Appears silver-grey

PZRN

A (PVD) process of placing a thin coating 2-10 microns thick over the working area of the punch.

Benefits

- * Surface hardness of 2800 Vickers
- * Dry coefficient of friction versus steel .5
- * Specially for non-ferrous materials
- * Appears yellow-gold

TICNMP

A (PVD) process of placing a thin coating 2-4 microns thick over the working area of the punch.

Benefits

- * Surface hardness of 3000 Vickers
- * Dry coefficient of friction versus steel .2
- * Specially for Galling issues in steel
- * Appears bronze

CRN

A (PVD) process of placing a thin coating 2-4 microns thick over the working area of the punch.

Benefits

- * Surface hardness of 2300 Vickers
- * Dry coefficient of friction versus steel .3
- * Specially for forming punches
- * Appears silver

Policy

Porter Precision Products guarantees its products to meet catalog specifications which are interchangeable and equivalent to I.S.O. standards. Print items and special description call-outs will be manufactured to the customer's specifications. No other warranties are expressed or implied.

All dimensions not specifically toleranced will be manufactured to industry (our Catalog) standards, regardless of the decimal place call-out. To eliminate misunderstandings, include tolerance charts on your prints or specifically tolerance critical dimensions.

Steel type is to be specified by the customer. If not specified, we will supply the first material listed in the catalog. It is always best to include your material choice in the part call-out as shown in the ordering examples.

Terms & Conditions

Prices- Net each and subject to change without notice.

Minimum Order Charge-There is no minimum order charge on manufactured items.

Terms-Net 30 Days, F.O.B. Shipping point

we also accept American Express, Master Card, and Visa

Credit- Orders are subject to the approval of our credit department. To expedite new accounts, furnish bank reference and three supplier references.

Returns- Credit claims for our manufactured items must be made within 45 days of shipment date. Stock blanks are returnable for credit less a 25% restocking fee. If they are exchanged for items of equal or greater value they can be returned for full credit. All items altered by us to the customer's specifications are the property of the buyer and are not returnable unless they do not meet catalog or print tolerances. Any item that has been altered by the customer is the said customer's responsibility and is for no reason returnable.

Over/Under Shipments- Manufactured products can vary up to 10% of the quantity ordered depending on the complexity of the part. If no variation is acceptable this information must be supplied to us at the time of quoting.

Cancellation- The customer will be responsible for a pro-rated charge to cover any work completed prior to cancellation.

Infringements- Customer shall assume all responsibility and undertake the defense of all lawsuits for infringements on patents brought against Porter Precision Products for the manufacture of products named in an order when said products are made according to drawings, samples, and/or descriptions that have been supplied by the customer.

Items supplied but not manufactured by us- All policies/terms & conditions set forth by the manufacturer of said items are applicable. Contact Porter Precision Products for information regarding various policies.



PORTER PRECISION PRODUCTS CO.

Corporate Office & Manufacturing Plant

2734 Banning Rd., Cincinnati, Ohio 45253-8706

Ph: (513) 923-3777 • Fax: (513) 923-1111

Toll Free (800) 543-7041

Porter@porterpunch.com

Georgia Manufacturing Plant

660 James Rd., Alpharetta, Ga. 30004

Ph: (770) 751-7234 • Fax: (770) 751-7238

Toll Free: (800) 437-5185

Georgia@porterpunch.com

Canada Plant

30 Duke Street West, Suite #503

Kitchener, Ontario, Canada N2H 3W5

Ph: (519) 746-3130 • Fax: (519) 746-6960

Toll Free: 1-800-265-8844

Canada@porterpunch.com



www.porterpunch.com

World Class Products That Perform!